

# CONTENTS

|                                                                  |    |
|------------------------------------------------------------------|----|
| I. Safety .....                                                  | 3  |
| 1.1 Safety information.....                                      | 3  |
| 1.2 Before using.....                                            | 8  |
| 1.3 Designed Standards for Implementation.....                   | 10 |
| II. Product .....                                                | 11 |
| 2.1 Product model naming rule.....                               | 11 |
| 2.2 Optional function naming rule.....                           | 12 |
| 2.3 Nameplate .....                                              | 13 |
| 2.4 Appearance.....                                              | 13 |
| 2.5 Technical Specifications .....                               | 16 |
| III. Keypad panel.....                                           | 19 |
| 3.1 Panel Illustrations.....                                     | 19 |
| 3.2 Panel Structure.....                                         | 21 |
| 3.3 Panel Operating .....                                        | 23 |
| 3.4 Parameters Setting .....                                     | 23 |
| 3.5 Function Codes Switchover In/Between Code-Groups.....        | 24 |
| 3.6 Panel Display .....                                          | 25 |
| IV. Installation & Connection .....                              | 26 |
| 4.1 Installation.....                                            | 26 |
| 4.2 Connection .....                                             | 26 |
| 4.3 Measurement of main circuit.....                             | 28 |
| 4.4 Function of Control Terminals.....                           | 32 |
| 4.5 Wiring Recommended.....                                      | 34 |
| 4.6 Lead Section Area of Protect Conductor(grounding wire) ..... | 34 |
| 4.7 Overall connection.....                                      | 35 |
| 4.8 Basic methods of suppressing the noise .....                 | 35 |
| V. Operation and Simple Running .....                            | 41 |

|             |                                                 |     |
|-------------|-------------------------------------------------|-----|
| 5.1         | Basic conception.....                           | 41  |
| 5.2         | Keypad panel and operation method.....          | 42  |
| 5.3         | Illustration of basic operation.....            | 47  |
| VI.         | Function Parameters .....                       | 53  |
| 6.1         | Basic Parameters.....                           | 53  |
| 6.2         | Operation Control .....                         | 62  |
| 6.3         | Multifunctional Input and Output Terminals..... | 74  |
| 6.4         | Analog Input and Output.....                    | 84  |
| 6.5         | Pulse input and output.....                     | 88  |
| 6.6         | Multi-stage Speed Control.....                  | 91  |
| 6.7         | Auxiliary Functions.....                        | 93  |
| 6.8         | Malfunction and Protection.....                 | 101 |
| 6.9         | Parameters of the motor.....                    | 105 |
| 6.10        | Communication parameters.....                   | 109 |
| 6.11        | PID parameters.....                             | 112 |
| 6.13        | Torque control parameters.....                  | 117 |
| 6.14        | Parameters of the second motor.....             | 119 |
| 6.15        | Parameters display.....                         | 119 |
| Appendix 1  | Trouble Shooting.....                           | 121 |
| Appendix 2  | Reference wiring of water system.....           | 123 |
| Appendix 3  | Products and Structure .....                    | 126 |
| Appendix 4  | Selection of Braking Resistance .....           | 131 |
| Appendix 5  | Communication Manual.....                       | 133 |
| Appendix 6  | Zoom Table of Function Code .....               | 143 |
| Appendix 7  | Encoder expansion card.....                     | 173 |
| Appendix 8  | Master/slave control.....                       | 181 |
| Appendix 9  | Input filter model and dimension.....           | 190 |
| Appendix 10 | Bus communication.....                          | 193 |

# I. Safety

Read this manual carefully so that you have a thorough understanding. Installation, commissioning or maintenance may be performed in conjunction with this chapter. EURA will assume no liability or responsibility for any injury or loss caused by improper operation.

## 1.1 Safety information

### 1.1.1 Application Area

The equipment described is intended for industrial motor speed control utilising AC induction motors.

### 1.1.2 Safety definition

**Danger:** series physical injury or even death may occur if not follow relevant requirements.









**Warning:** Physical injury or damage to the devices may occur if not follow relevant requirements.

**Note:** Physical hurt may occur if not follow relevant requirements.

**Qualified electricians:** People working on the device should take part in professional electrical and safety training, receive the certification and be familiar with all steps and requirements of installing, commissioning, operating and maintaining the device to avoid any emergency.





### 1.1.3 Warning symbols

Warning caution you about conditions which can result in serious injury or death and/or damage to the equipment, and advice on how to avoid the danger. Following warning symbols are used in this manual.

| Symbols                                                                                              | Name                    | Instruction                                                                                 | Abbreviation                                                                        |
|------------------------------------------------------------------------------------------------------|-------------------------|---------------------------------------------------------------------------------------------|-------------------------------------------------------------------------------------|
|  <b>Danger</b>      | Electrical danger       | Serious physical injury or even may occur if not follow the relative requirements.          |    |
|  <b>Hot sides</b> | Hot sides               | Sides of the device may become hot. Do not touch.                                           |  |
|  <b>Warning</b>   | Warning                 | Physical injury or damage to the devices may occur if not follow the relative requirements. |  |
|  <b>Do not</b>    | Electrostatic discharge | Damage to the PCB board may occur if not follow the relative requirements.                  |  |

|             |      |                                                                  |             |
|-------------|------|------------------------------------------------------------------|-------------|
| <b>Note</b> | Note | Physical hurt may occur if not follow the relative requirements. | <b>Note</b> |
|-------------|------|------------------------------------------------------------------|-------------|

**1.1.4 Safety guidelines**

|    | <p>◇ Only qualified electricians are allowed to operate on the inverter.</p> <p>◇ Do not carry out any wiring and inspection or changing components when the power supply is applied. Ensure all input power supply is disconnected before wiring and checking and always wait for at least the time designated on the inverter or until the DC bus voltage is less than 36V. Below is the table of the waiting time:</p> <table border="1" style="margin-left: 20px;"> <thead> <tr> <th style="text-align: center;">inverter model</th> <th style="text-align: center;">Min theoretical waiting time</th> </tr> </thead> <tbody> <tr> <td style="text-align: center;">400V 1.5kW – 110kW</td> <td style="text-align: center;">5 minutes</td> </tr> <tr> <td style="text-align: center;">400V 132kW – 315kW</td> <td style="text-align: center;">30 minutes</td> </tr> <tr> <td style="text-align: center;">400V above 350kW</td> <td style="text-align: center;">45 minutes</td> </tr> </tbody> </table> | inverter model | Min theoretical waiting time | 400V 1.5kW – 110kW | 5 minutes | 400V 132kW – 315kW | 30 minutes | 400V above 350kW | 45 minutes |
|-------------------------------------------------------------------------------------|-----------------------------------------------------------------------------------------------------------------------------------------------------------------------------------------------------------------------------------------------------------------------------------------------------------------------------------------------------------------------------------------------------------------------------------------------------------------------------------------------------------------------------------------------------------------------------------------------------------------------------------------------------------------------------------------------------------------------------------------------------------------------------------------------------------------------------------------------------------------------------------------------------------------------------------------------------------------------------------------------------------|----------------|------------------------------|--------------------|-----------|--------------------|------------|------------------|------------|
| inverter model                                                                      | Min theoretical waiting time                                                                                                                                                                                                                                                                                                                                                                                                                                                                                                                                                                                                                                                                                                                                                                                                                                                                                                                                                                              |                |                              |                    |           |                    |            |                  |            |
| 400V 1.5kW – 110kW                                                                  | 5 minutes                                                                                                                                                                                                                                                                                                                                                                                                                                                                                                                                                                                                                                                                                                                                                                                                                                                                                                                                                                                                 |                |                              |                    |           |                    |            |                  |            |
| 400V 132kW – 315kW                                                                  | 30 minutes                                                                                                                                                                                                                                                                                                                                                                                                                                                                                                                                                                                                                                                                                                                                                                                                                                                                                                                                                                                                |                |                              |                    |           |                    |            |                  |            |
| 400V above 350kW                                                                    | 45 minutes                                                                                                                                                                                                                                                                                                                                                                                                                                                                                                                                                                                                                                                                                                                                                                                                                                                                                                                                                                                                |                |                              |                    |           |                    |            |                  |            |
|    | <p>◇ The base of the radiator may become hot during running. Do not touch to avoid hurt.</p>                                                                                                                                                                                                                                                                                                                                                                                                                                                                                                                                                                                                                                                                                                                                                                                                                                                                                                              |                |                              |                    |           |                    |            |                  |            |
|  | <p>◇ Do not refit the inverter unauthorizedly; otherwise fire, electric shock or other injury may occur.</p> <p>◇ Never touch power terminals internal inverter to avoid any electric shock.</p> <p>◇ Do not connect input power supply onto U, V, W or PE/E terminals.</p> <p>◇ Do not install inverter directly under sunshine, do not block up the cooling hole.</p> <p>◇ All safety covers should be well fixed before inverter is power connected, to avoid any electric shock.</p>                                                                                                                                                                                                                                                                                                                                                                                                                                                                                                                  |                |                              |                    |           |                    |            |                  |            |
|  | <p>◇ The electrical parts and components inside the inverter are electrostatic. Take measurements to avoid electrostatic discharge relevant operation.</p>                                                                                                                                                                                                                                                                                                                                                                                                                                                                                                                                                                                                                                                                                                                                                                                                                                                |                |                              |                    |           |                    |            |                  |            |

### 1.1.5 Delivery and installation



- ◇ Please install the inverter on fire-retardant material and keep the inverter away from combustible materials.
- ◇ Connect the braking optional parts (braking resistors, braking units or feedback units) according to the wiring diagram.
- ◇ Do not operate on the inverter if there is any damage or components loss to the inverter.
- ◇ Do not touch the inverter with wet items or body, otherwise electric shock may occur.
- ◇ Select appropriate moving and installing tools to ensure a safe and normal running of the inverter and avoid physical injury or death. For physical safety, the erector should take some mechanical protective measurements, such as wearing exposure shoes and working uniforms.
- ◇ Ensure to avoid physical shock or vibration during delivery and installation.
- ◇ Do not carry the inverter by its cover to avoid cover falling off.
- ◇ Install away from children and other public placers.
- ◇ Derating must be considered when the drive is installed at high altitude, greater than 1000m. This is because the cooling effect of drive is deteriorated due to the thin air, as shown in Fig1-1 that indicates the relationship between the elevation and rated current of the drive.
- ◇ Forbidden screws, cables and other conductive items to fall inside the inverter.
- ◇ Proper grounding should be ensured with grounding resistance not exceeding  $4\Omega$ ; separate grounding is required for motor and inverter. Grounding with series connection is forbidden.
- ◇ R, S and T are the input terminals of the power supply, while U, V and

We are the motor terminals. Please connect the input power cables and motor cables with proper techniques; otherwise the damage to the inverter may occur.

◇ If inverter is installed in a control cabinet, smooth ventilation should be ensured and inverter should be installed vertically (as shown in Fig1-2). If there are several inverters in one cabinet, in order to ensure ventilation, please install inverters side by side. If it is necessary to install several inverters up and down, please add heat-insulation plate (as shown in Fig1-3).

◇ Signal line should not be too long to avoid any increase with common mode interference.

◇ Before using the drive, the insulation of the motors must be checked, especially, if it is used for the first time or if it has been stored for a long time. This is to reduce the risk of the drive from being damaged by the poor insulation of the motor.

◇ Do not connect any varistor or capacitor to the output terminals of the drive, because the drive's output voltage waveform is pulse wave, otherwise tripping or damaging of components may occur; in addition, do not install circuit breaker or contactor at the output side of the drive as shown in Fig 1-4.

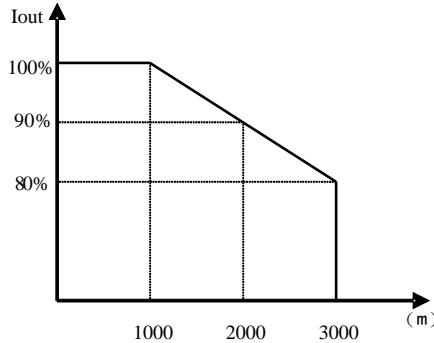

**Fig 1-1 Derating drive's output current with altitude**

## Installing vertically

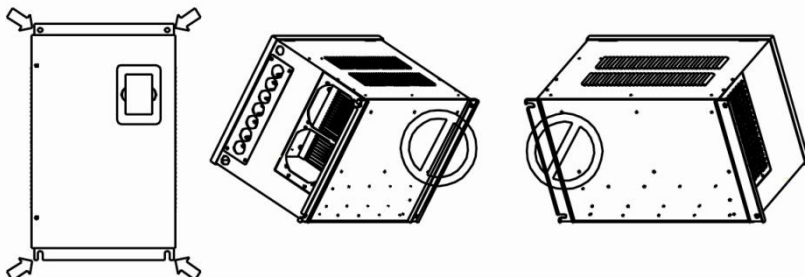

Fig 1-2 Installing vertically

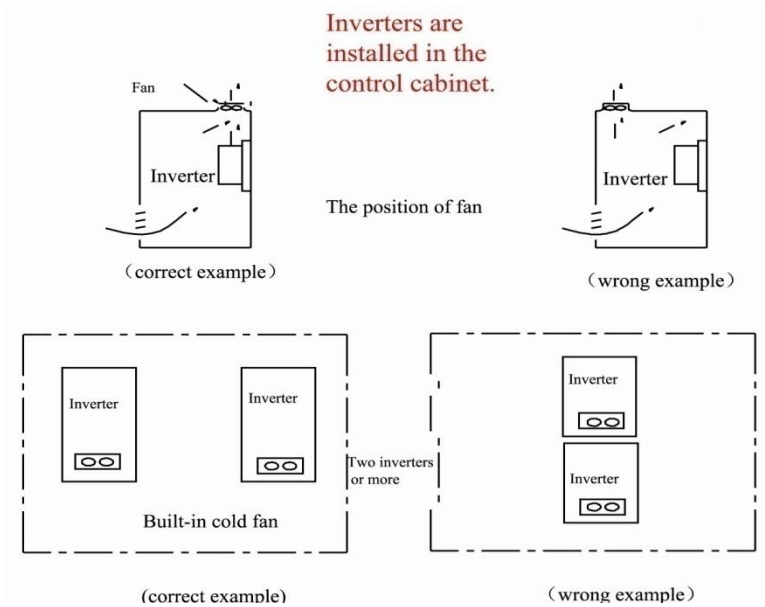
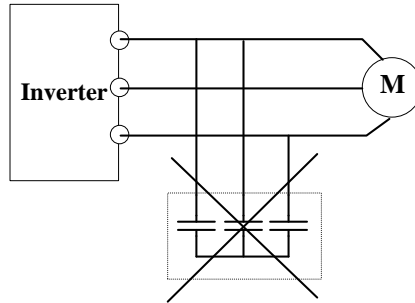

Fig 1-3 Installed in the cabinet



**Fig 1-4 Capacitors are prohibited to be used.**

## 1.2 Before using

### 1.2.1 Unpacking inspection



Check as followings after receiving products:

- |                                                                                                                                                                                                         |
|---------------------------------------------------------------------------------------------------------------------------------------------------------------------------------------------------------|
| 1. Check that there are no damage and humidification to the package. If not, please contact with local agents or company offices.                                                                       |
| 2. Check the information on the type designation label on the outside of the package to verify that the drive is of the correct type. If not, please contact with local dealers or company offices.     |
| 3. Check that there are no signs of water in the package and no signs of damage or breach to the inverter. If not, please contact with local dealers or company offices.                                |
| 4. Check the information on the type designation label on the outside of the package to verify that the nameplate is of the correct type. If not, please contact with local dealers or company offices. |
| 5. Check to ensure the accessories (including user manual, control keypad and extension card) inside the device is complete. If not, please contact with local dealers or company offices.              |

### 1.2.2 Application confirmation



Check the machine before beginning to use the inverter:

- |                                                                                                                                                           |
|-----------------------------------------------------------------------------------------------------------------------------------------------------------|
| 1. Check the load type to verify that there is no overload of the inverter during work and check that whether the drive needs to modify the power degree. |
| 2. Check that the actual current of the motor is less than the rated current of the                                                                       |



|                                                                                                  |
|--------------------------------------------------------------------------------------------------|
| inverter.                                                                                        |
| 3. Check that the control accuracy of the load is the same of the inverter.                      |
| 4. Check that the incoming supply voltage is correspondent to the rated voltage of the inverter. |
| 5. Check that the communication needs option card or not.                                        |

### 1.2.3 Environment



Check as followings before the actual installation and usage:

|                                                                                                                                                                                                                                                                                                                    |
|--------------------------------------------------------------------------------------------------------------------------------------------------------------------------------------------------------------------------------------------------------------------------------------------------------------------|
| 1. Check that the ambient temperature of the inverter is below 50°C. If exceeds, derate 3% for every additional 1°C. Additionally, the inverter can not be used if the ambient temperature is above 60°C.<br>Note: for the cabinet inverter, the ambient temperature means the air temperature inside the cabinet. |
| 2. Check that the ambient temperature of the inverter in actual usage is above -10°C. If not, add heating facilities.<br>Note: for the cabinet inverter, the ambient temperature means the air temperature inside the cabinet.                                                                                     |
| 3. Check that the altitude of the actual usage site is below 1000m. If exceeds, derate 1% for every additional 100m.                                                                                                                                                                                               |
| 4. Check that the humidity of the actual usage site is below 90% and condensation is not allowed. If not, add additional protection inverters.                                                                                                                                                                     |
| 5. Check that the actual usage site is away from direct sunlight and foreign objects cannot enter the inverter. If not, add additional protective measures.                                                                                                                                                        |
| 6. Check that there is no conductive dust or flammable gas in the actual usage site. If not, add additional protection to inverters.                                                                                                                                                                               |

### 1.2.4 Installation confirmation



Check as followings after the installation:

|                                                                                                                                                                                                                                                                           |
|---------------------------------------------------------------------------------------------------------------------------------------------------------------------------------------------------------------------------------------------------------------------------|
| 1. Check that the load range of the input and output cables meet the need of actual load.                                                                                                                                                                                 |
| 2. Check that the accessories of the inverter are correctly and properly installed. The installation cables should meet the needs of every component (including input chokes, input filters, output chokes, output filters, DC choke, braking unit and braking resistor.) |

|                                                                                                                                                                    |
|--------------------------------------------------------------------------------------------------------------------------------------------------------------------|
| 3. Check that the inverter is installed on non-flammable materials and the calorific accessories (chokes and braking resistors) are away from flammable materials. |
| 4. Check that all control cables and power cables are run separately and the rotation complies with EMC requirement.                                               |
| 5. Check that all grounding systems are properly grounded according to the requirements of the inverters.                                                          |
| 6. Check that the free space during installation is sufficient according to the instructions in user manual.                                                       |
| 7. Check that the installation conforms to the instructions in user manual. The drive must be installed in a vertical position.                                    |
| 8. Check that the external connection terminals are tightly fastened and the torque is appropriate.                                                                |
| 9. Check that there are no screws, cables and other conductive items left in the inverter. If not, get them out.                                                   |

### 1.2.5 Basic commission



Complete the basic commissioning as followings before actual utilization:

|                                                                                                                                                                   |
|-------------------------------------------------------------------------------------------------------------------------------------------------------------------|
| 1. Select the motor type, set correct motor parameters and select control mode of the inverter according to the actual motor parameters.                          |
| 2. Auto-tune. If possible, disconnected from the motor load to start dynamic auto-tune. Or if not, static auto-tune is available.                                 |
| 3. Adjust acceleration/deceleration time according to actual running of load.                                                                                     |
| 4. Commission the device via jogging and check that the rotation direction is as required. If not, change the rotation direction by changing the wiring of motor. |
| 5. Set all control parameters and then operate.                                                                                                                   |

### 1.3 Designed Standards for Implementation

- IEC/EN 61800-5-1: 2007 Adjustable speed electrical power drive systems safety requirements.
- IEC/EN 61800-3: 2004/ +A1: 2012 Adjustable speed electrical power drive systems-Part 3: EMC product standard including specific test methods.

## II. Product

This manual offers a brief introduction of the installation connection for E2000 series inverters, parameters setting and operations, and should therefore be properly kept. Please contact manufacturer or dealer in case of any malfunction during application.

### 2.1 Product model naming rule

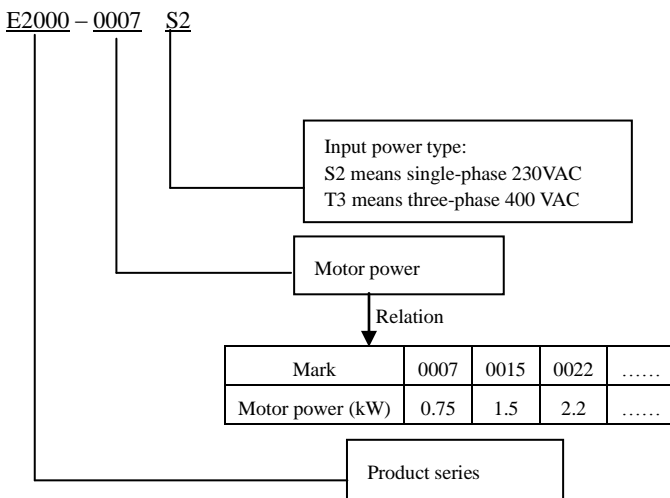

### 2.2 Function naming rule

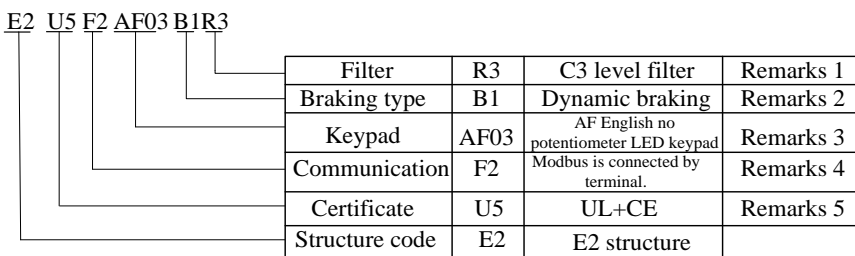

#### Remarks:

1. Filter for 45kw and below 45kw includes R3 and R5. R3 is EMC C3 level standard (testing condition is 25m motor cable). R5 is EMC C3 level standard (testing condition is 10m unshielded motor cable). R5 is standard, R3 is optional. 55kw and above 55kw meet the need of EMC C3 level standard.
2. For 3-phase 400V 30kw and below 30kW, braking unit is standard.

**For 1-phase 230V and 3-phase 37kW-110kW, braking unit is built-in and optional.**  
**For 3-phase 230V, 1.5kW and below 1.5kW, 4.0kW~11kW, braking unit is standard.**  
**For 132kW and above 132kW, there is no built-in braking unit.**

**3. Local keypad :**

| Structure code                            | Keypad code | Contents                                   |
|-------------------------------------------|-------------|--------------------------------------------|
| E1                                        | AE01        | AE Chinese version without potentiometer   |
|                                           | AE02        | AE Chinese version with potentiometer      |
|                                           | AE03        | AE English version without potentiometer   |
|                                           | AE04        | AE English version with potentiometer      |
| E2~E6                                     | AF01        | AF Chinese version without potentiometer   |
|                                           | AF02        | AF Chinese version with potentiometer      |
|                                           | AF03        | AF English version without potentiometer   |
|                                           | AF04        | AF English version with potentiometer      |
| A6 Chinese LED with digital potentiometer | A601        | A6 Chinese LED without potentiometer       |
|                                           | A602        | A6 Chinese LED with potentiometer          |
|                                           | A603        | A6 English LED without potentiometer       |
|                                           | A604        | A6 English LED with potentiometer          |
|                                           | A605        | A6 Chinese 9-key LED without potentiometer |
|                                           | A606        | A6 Chinese 9-key LED with potentiometer    |
|                                           | A607        | A6 English 9-key LED without potentiometer |
|                                           | A608        | A6 English 9-key LED with potentiometer    |
|                                           | A612        | A6 Chinese LED with digital potentiometer  |
|                                           | A614        | A6 English LED with digital potentiometer  |
|                                           | A902        | A9 English LCD4 without potentiometer      |
|                                           | A904        | A9 Chinese LCD4 without potentiometer      |

**Remote keypad model:**

| Keypad |                                            |
|--------|--------------------------------------------|
| A601   | A6 Chinese LED without potentiometer       |
| A602   | A6 Chinese LED with potentiometer          |
| A603   | A6 English LED without potentiometer       |
| A604   | A6 English LED with potentiometer          |
| A605   | A6 Chinese 9-key LED without potentiometer |
| A606   | A6 Chinese 9-key LED with potentiometer    |
| A607   | A6 English 9-key LED without potentiometer |

|      |                                              |
|------|----------------------------------------------|
| A608 | A6 English 9-key LED with potentiometer      |
| A612 | A6 Chinese LED with digital potentiometer    |
| A614 | A6 English LED with digital potentiometer    |
| A902 | A9 English LCD4 without potentiometer        |
| A904 | A9 Chinese LCD4 without potentiometer        |
| AA01 | AA Chinese LED without potentiometer         |
| AA02 | AA Chinese LED with potentiometer            |
| AA03 | AA English LED without potentiometer         |
| AA04 | AA English LED with potentiometer            |
| AA05 | AA Chinese/English LED without potentiometer |

#### 4. Communication

| Structure code         | Communication code | Contents           |
|------------------------|--------------------|--------------------|
| E1                     | F2                 | Modbus             |
| E2 structure and above | F2                 | Modbus             |
|                        | F4                 | CANOpen+Modbus     |
|                        | F5                 | EtherCAT+Modbus    |
|                        | F9                 | Profibus-DP+Modbus |
|                        | F12                | BACnet+Modbus      |

#### 5. Certificate



| Certificate code | Contents | Inverter power |
|------------------|----------|----------------|
| U1               | CE       | ≤800kW         |
| U5               | UL+CE    | ≤180kW         |

## 2.3 Nameplate

Taking for instance the E2000 series 0.75kW inverter with 1-phase input, its nameplate is illustrated as Fig 1-1.

1Ph: single-phase input; 230V, 50/60Hz: input voltage range and rated frequency.

3Ph: 3-phase output; 4.5A, 0.75kW: rated output current and power;

|  <b>EURA DRIVES ELECTRIC CO.,LTD</b>                          |              |               |                |
|--------------------------------------------------------------------------------------------------------------------------------------------------|--------------|---------------|----------------|
| <b>MODEL</b>                                                                                                                                     | E2000-0007S2 | <b>OPTION</b> | E1U1F2AE02B1R3 |
| <b>INPUT</b>                                                                                                                                     | 1PH AC       | 220 V         | 50/60 Hz       |
| <b>OUTPUT</b>                                                                                                                                    | 3PH AC       | 0~INPUT V     | 4.5 A          |
|                                                                                                                                                  | 0.75kW       |               |                |
|  <b>IP20</b> <span style="float: right;">Made In China</span> |              |               |                |

## 2.4 Product appearance

### 2.4.1 Appearance

The external structure of E2000 series inverter is classified into plastic and metal housings. Wall hanging type and cabinet type are adopted. Good poly-carbon materials are adopted through die-stamping for plastic housing with nice form, good strength and toughness. Taking E2000-0007S2 for instance, the external appearance and structure are shown as in below Fig.

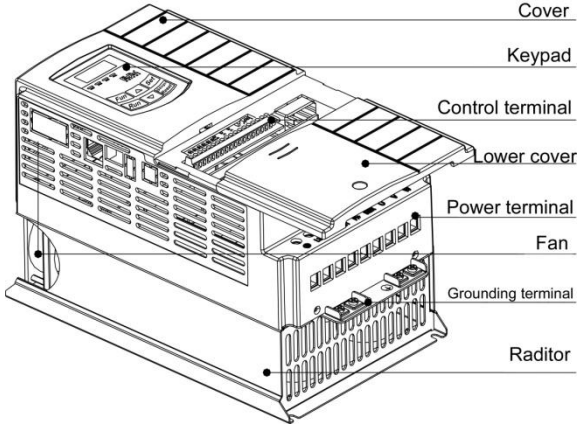

Metal housing uses advanced exterior plastic- spraying and powder-spraying process on the surface with elegant color and with detachable one-side door hinge structure adopted for front cover, convenient for wiring and maintenance. Taking E2000-0300T3 for instance, its appearance and structure are shown as in right Fig.

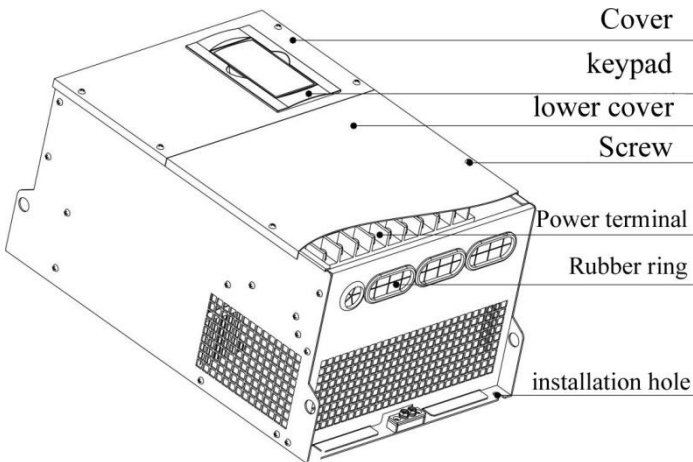

## 2.4.2 Interface

### (1) E1 structure

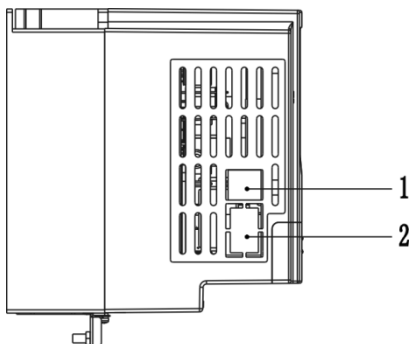

### (2) E2-E6 structure

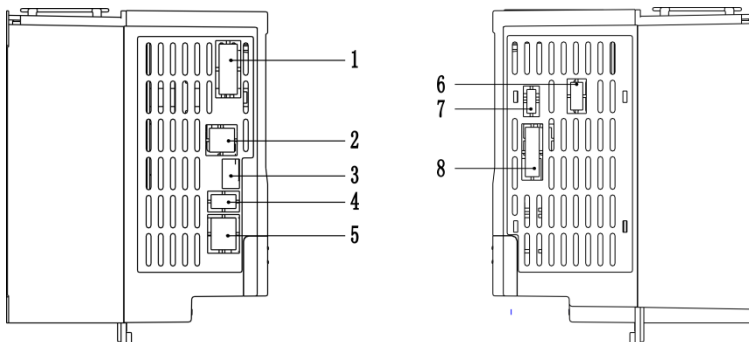

### (3) E7 and Metal structure

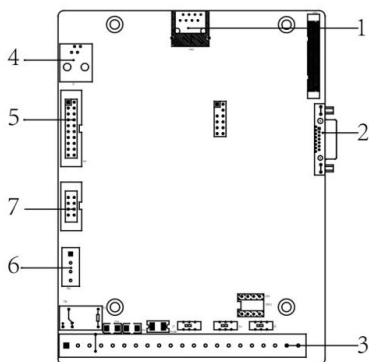

Table 2-1 E2000 interface introduction

| Structure No. | Contents                                 |                                               |                                               |
|---------------|------------------------------------------|-----------------------------------------------|-----------------------------------------------|
|               | E1 structure                             | E2~E6 structure                               | E7 and metal structure                        |
| 1             | 8-core net cable remote keypad interface | Bus communication interface                   | 8-core net cable remote keypad interface      |
| 2             | RS-485 communication (A+,B-)             | 8-core net cable remote keypad interface      | Bus communication interface                   |
| 3             |                                          | RS-485 communication (A+,B-)                  | Control terminal                              |
| 4             |                                          | Master/slave control expansion card interface | Master/slave control expansion card interface |
| 5             |                                          | Reserved                                      | PG card expansion interface                   |
| 6             |                                          | STO card expansion interface (E4~E6)          | RS-485 communication (A+,B-)                  |
| 7             |                                          | STO card expansion interface (E2,E3)          | BACnet interface                              |
| 8             |                                          | PG card expansion interface                   |                                               |

## 2.5 Technical Specifications

Table2-2 Technical Specifications for E2000 Series Inverters

|              | Items                      | Contents                                                                                                                                                                 |
|--------------|----------------------------|--------------------------------------------------------------------------------------------------------------------------------------------------------------------------|
| Input        | Rated Voltage Range        | 3-phase 380-480V (+10%, -15%) <sup>note 1</sup><br>3-phase 220V~240V ±15%<br>1-phase 220-240V ±15%                                                                       |
|              | Rated Frequency            | 50/60Hz                                                                                                                                                                  |
| Output       | Rated Voltage Range        | 3-phase 0-INPUT (V)                                                                                                                                                      |
|              | Frequency Range            | 0.50~650.0Hz (In SVC control mode, the max frequency should be lower than 500Hz.)                                                                                        |
| Control Mode | Carrier Frequency          | 800~16000Hz; Fixed carrier-wave and random carrier-wave can be selected by F159.                                                                                         |
|              | Input Frequency Resolution | Digital setting: 0.01Hz, analog setting: max frequency X 0.1%                                                                                                            |
|              | Control Mode               | For induction motor:<br>SVC (open-loop vector control) control, V/F control, VC (Closed-loop vector control) control<br>For PMSM: SVC (open-loop vector control) control |
|              | Start Torque               | 0.5 Hz / 150% (SVC), 0Hz/180% (VC),<br>5% of rated speed/100% of rated torque (PMSM SVC)                                                                                 |
|              | Speed-control Scope        | 1:100 (SVC), 1:1000 (VC), 1:20 (in PMSM SVC)                                                                                                                             |
|              | Steady Speed Precision     | ±0.5% (SVC) , ±0.02% (VC)                                                                                                                                                |
|              | Torque Control Precision   | ±5%                                                                                                                                                                      |
|              | Overload Capacity          | 150% rated current, 60 seconds.                                                                                                                                          |
|              | Torque Elevating           | Auto torque promotion, Manual Torque Promotion includes 1-20 curves.                                                                                                     |



|                        |                                                                                                                                                                                                                                                                                                                   |                                                                                                                                                        |
|------------------------|-------------------------------------------------------------------------------------------------------------------------------------------------------------------------------------------------------------------------------------------------------------------------------------------------------------------|--------------------------------------------------------------------------------------------------------------------------------------------------------|
|                        | V/F Curve                                                                                                                                                                                                                                                                                                         | 3 kinds of modes: beeline type, square type and under-defined V/F curve.                                                                               |
|                        | Startup mode                                                                                                                                                                                                                                                                                                      | Direct startup, speed track startup (V/F control)                                                                                                      |
|                        | DC Braking                                                                                                                                                                                                                                                                                                        | DC braking frequency: 0.20-50.00 Hz, braking time: 0.00~30.00s                                                                                         |
|                        | Jogging Control                                                                                                                                                                                                                                                                                                   | Jogging frequency range: min frequency~ max frequency, jogging acceleration/deceleration time: 0.1~3000s                                               |
|                        | Auto Circulating Running and multi-stage speed running                                                                                                                                                                                                                                                            | Auto circulating running or terminals control can realize 15-stage speed running.                                                                      |
|                        | Built-in PID adjusting                                                                                                                                                                                                                                                                                            | Easy to realize a system for process closed-loop control                                                                                               |
|                        | Auto voltage regulation (AVR)                                                                                                                                                                                                                                                                                     | When source voltage changes, the modulation rate can be adjusted automatically, so that the output voltage is unchanged.                               |
| Operation Function     | Frequency Setting                                                                                                                                                                                                                                                                                                 | Potentiometer or external analog signal (0~5V, 0~10V, 0~20mA); keypad (terminal) ▲ / ▼ keys, external control logic and automatic circulation setting. |
|                        | Start/Stop Control                                                                                                                                                                                                                                                                                                | Terminal control, keypad control or communication control.                                                                                             |
|                        | Running Command Channels                                                                                                                                                                                                                                                                                          | 3 kinds of channels from keypad panel, control terminal and MODBUS.                                                                                    |
|                        | Frequency Source                                                                                                                                                                                                                                                                                                  | Frequency sources: given digit, given analog voltage, given analog current and given MODBUS                                                            |
|                        | Accessorial frequency Source                                                                                                                                                                                                                                                                                      | 7 kinds of accessorial frequency                                                                                                                       |
| Optional               | Built-in EMI filter, built-in braking unit, Modbus, tele-control panel                                                                                                                                                                                                                                            |                                                                                                                                                        |
| Protection Function    | Input phase loss, Output phase loss, input under-voltage, DC over-voltage, over-current, inverter over-load, motor over-load, current stall, over-heat, external disturbance, under-load, pressure control, analog line disconnected, PG line disconnection, keypad disconnection, oPEn protection, STO and STO1. |                                                                                                                                                        |
| Display                | Keypad showing present output frequency, present rotate-speed (rpm), present output current, present output voltage, present linear-velocity, types of faults, and parameters for the system and operation; LED indicators showing the current working status of inverter.                                        |                                                                                                                                                        |
| Environment Conditions | Equipment Location                                                                                                                                                                                                                                                                                                | In an indoor location, Prevent exposure from direct sunlight, Free from dust, tangy caustic gases, flammable gases, steam or the salt-contented, etc.  |
|                        | Environment Temperature                                                                                                                                                                                                                                                                                           | -10℃~+50℃                                                                                                                                              |
|                        | Environment Humidity                                                                                                                                                                                                                                                                                              | Below 90% (no water-bead coagulation)                                                                                                                  |
|                        | Vibration Strength                                                                                                                                                                                                                                                                                                | Below 0.5g (acceleration)                                                                                                                              |
|                        | Height above sea level                                                                                                                                                                                                                                                                                            | 1000m or below                                                                                                                                         |
| Protection level       | IP20                                                                                                                                                                                                                                                                                                              |                                                                                                                                                        |
| Applicable Motor       | 0.2~800kW                                                                                                                                                                                                                                                                                                         |                                                                                                                                                        |

**Note 1:** under different voltage level, user should connect jumper on the pin board, the model of pin board is E2F3UZ00.

- 1) When input voltage is 380~420VAC, please connect CN2 to CN3 (380V Jumper).
- 2) When input voltage is 420~480VAC, please connect CN4 to CN5(480V Jumper).

The default system is 380~420VAC, if some operation is needed, please power off inverter and contact with profession engineer.

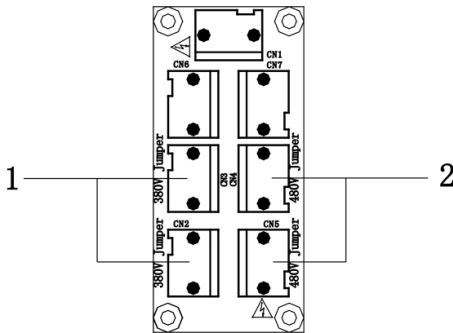

## 2.6 Options

| Name                                | Model       | Function                                                       | Remarks                                                                                              |
|-------------------------------------|-------------|----------------------------------------------------------------|------------------------------------------------------------------------------------------------------|
| Input/output expansion card 2       | EDR02       | 4 terminals of digital input, and 2 terminals of relay output. | Please refer to instructions of FF00~FF09.                                                           |
| Differential input PG card          | EPG01       | Card with Frequency-division output rotary encoder port.       | 5V power and differential output encoder are suitable. Please refer to Appendix 7.                   |
| Non-differential input PG card      | EPG02       | Card with frequency-division output rotary encoder port.       | 15V power and push-pull or open-collector output encoder are suitable. Please refer to Appendix 7.   |
| EtherCAT                            | EIB-ESSI01  | EtherCAT communication (built-in)                              | Please refer to bus appendix 10.                                                                     |
|                                     | EIB-ESSE01  | EtherCAT communication (external)                              |                                                                                                      |
| CANopen                             | EIB-CSSI01  | CANopen communication (built-in)                               |                                                                                                      |
|                                     | EIB-CSSE01  | CANopen communication (external)                               |                                                                                                      |
| Profibus                            | EIB-PDSSI01 | Profibus-DP communication (built-in)                           |                                                                                                      |
|                                     | EIB-PDSSE01 | Profibus-DP communication (external)                           |                                                                                                      |
| BACnet                              | EIB-BSSI01  | BACnet communication (built-in)                                | Refer to the user manual of BACnet <sup>note</sup>                                                   |
|                                     | EIB-BSSE01  | BACnet communication (external)                                |                                                                                                      |
| Master/slave control expansion card | EMSC01      | Master/slave control.                                          | This card is needed when three or more inverters are connected together. Please refer to appendix 8. |

Note:

1. BACnet card is only external now.
2. The structures of some frequency inverters with BACnet card change to E2. The models are as below:

| Model        | Power | Structure |
|--------------|-------|-----------|
| E2000-0004S2 | 0.4   | E2        |
| E2000-0007S2 | 0.75  | E2        |
| E2000-0015S2 | 1.5   | E2        |
| E2000-0002T2 | 0.2   | E2        |

|              |      |    |
|--------------|------|----|
| E2000-0004T2 | 0.4  | E2 |
| E2000-0007T2 | 0.75 | E2 |
| E2000-0015T2 | 1.5  | E2 |
| E2000-0007T3 | 0.75 | E2 |

### III. Keypad panel

Two kinds of controllers (four lines of LCD and LED segment display) are available for E2000 series inverters. Refer to note for Fig3-1.

#### 3.1 Panel Illustration

##### 3.1.1 LED keypad

The panel covers three sections: data display section, status indicating section and keypad operating section, as shown in Fig. 3-1.

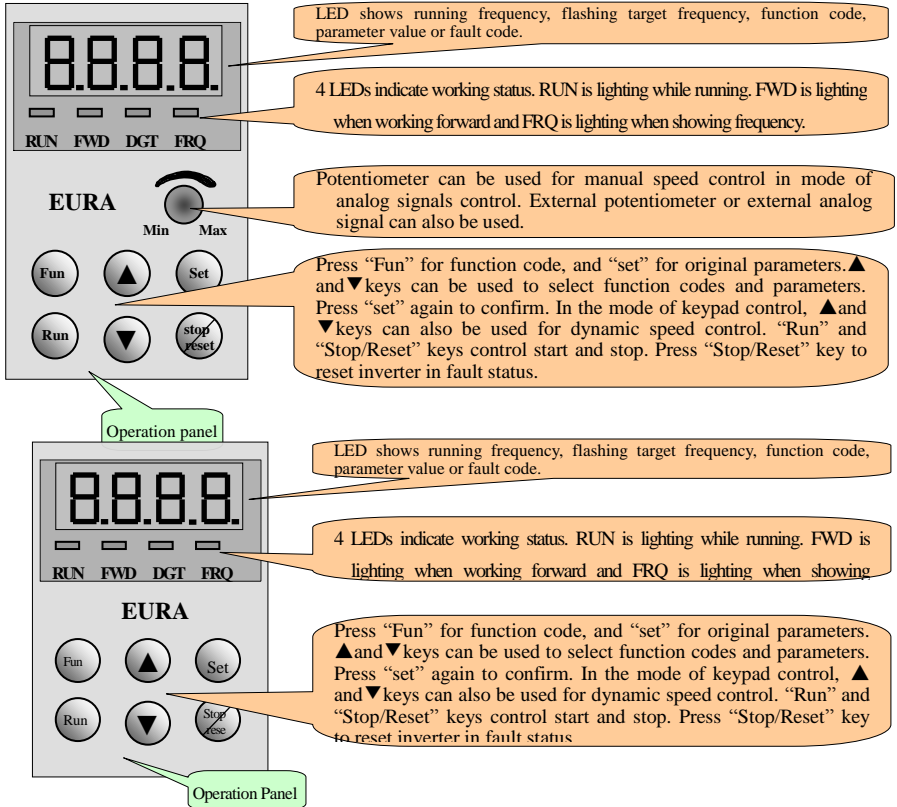

Fig.3-1 Operation Panels

### 3.1.2 LED remote keypad

The panel covers three sections: data display section, status indicating section and keypad operating section, as shown in Fig. 3-2.

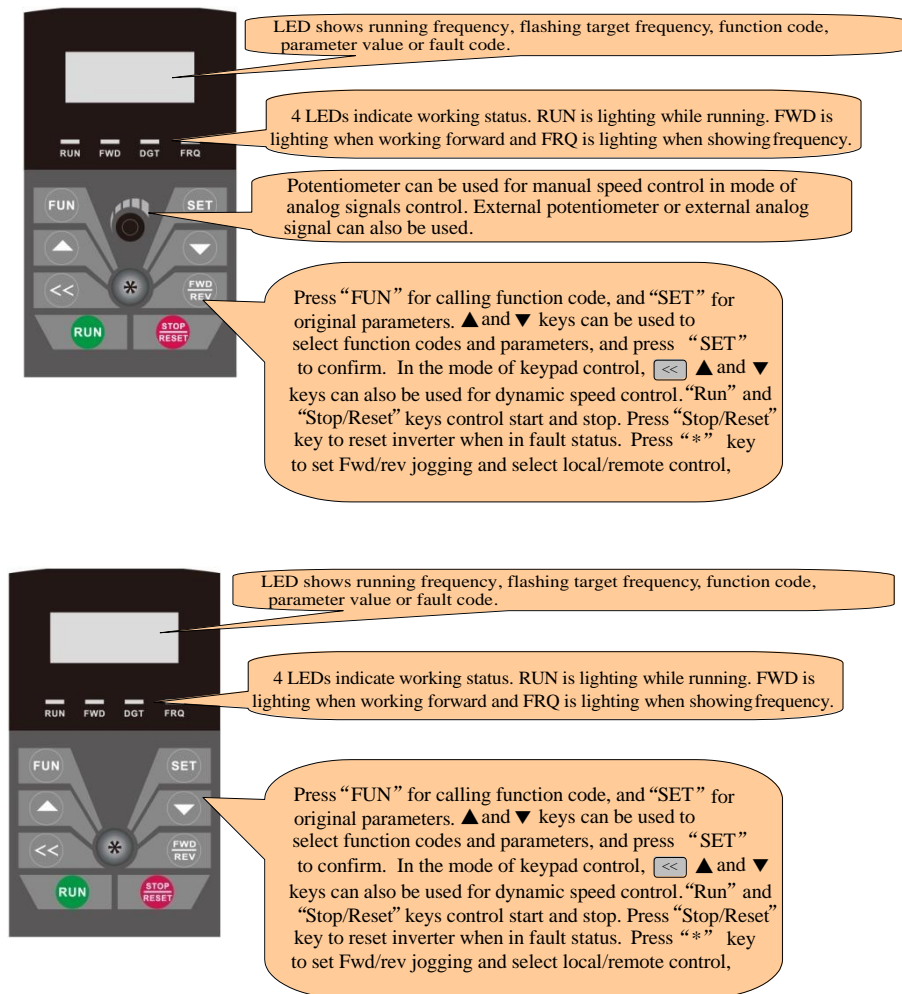

Fig.3-2 Operation Panels

### 3.1.3 Four lines of LCD keypad

The panel covers three sections: data display section, status indicating section and keypad operating section, as shown in Fig 3-2.

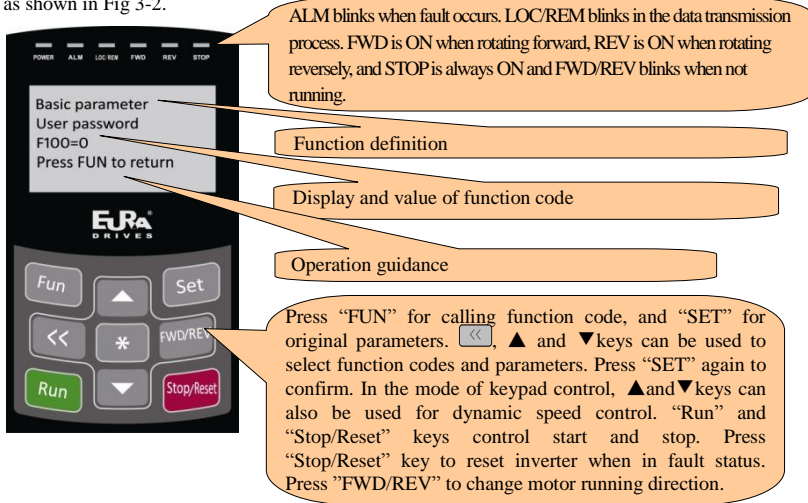

Fig.3-3 Operation Panels

Instructions for operation panel:

1. Operation panels of 30kW and below 30kW cannot be pulled out. Please select AA-A or A6-1-A control panel to realize remote control, which is connected by 8-core telephone cable.
2. Operation panels of 30kW and above 37kW can be pulled out. Please select A6-1-A control panel to realize remote control, which is connected by 8 core net cable.
3. A9 is four lines of LCD keypad, which is not standard configuration.

## 3.2 Panel structure

### 1. structure diagram

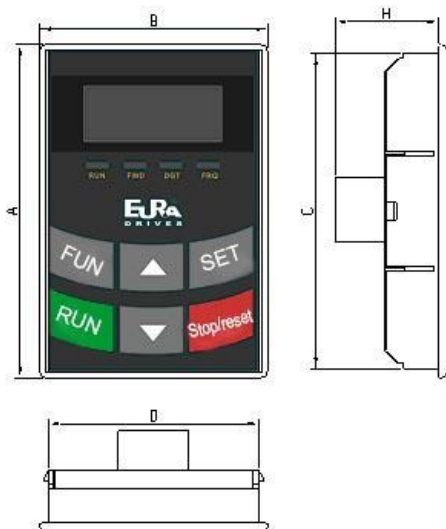

### 2. Structure size (Unit: mm)

| Code        | A   | B  | C   | D  | H  | Opening size |
|-------------|-----|----|-----|----|----|--------------|
| <b>AA</b>   | 76  | 52 | 72  | 48 | 24 | 73*49        |
| <b>A6-1</b> | 124 | 74 | 120 | 70 | 26 | 121*71       |
| <b>A9</b>   | 124 | 74 | 120 | 70 | 24 | 121*71       |

### 3. Panel mounting structure diagram

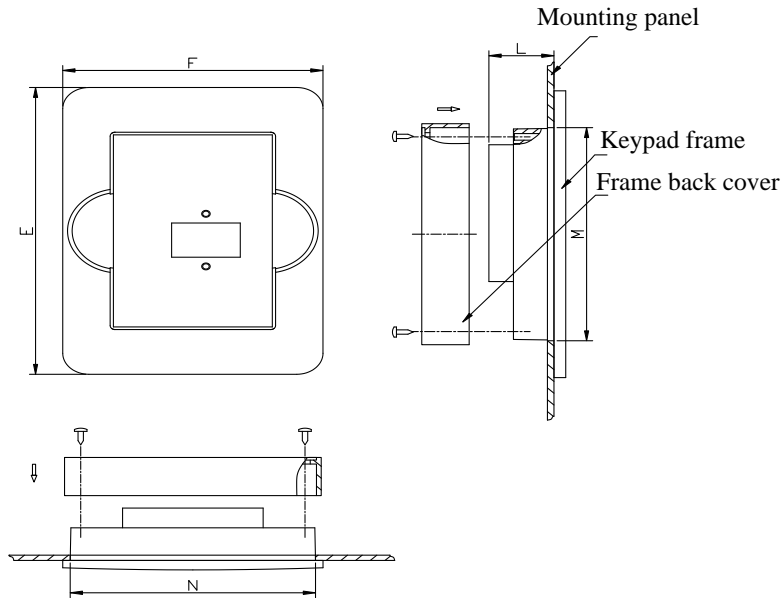

4. Panel mounting size (Unit: mm)

| Code | Keypad panel size |     |    | Opening size |     |
|------|-------------------|-----|----|--------------|-----|
|      | E                 | F   | L  | <u>N</u>     | M   |
| AA   | 109               | 80  | 20 | 75           | 81  |
| A6-1 | 170               | 110 | 22 | 102          | 142 |
| A9   | 170               | 110 | 22 | 102          | 142 |

5. Port of control panel

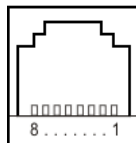

| Pins   | 1             | 2  | 3         | 4         | 5        | 6        | 7        | 8        |
|--------|---------------|----|-----------|-----------|----------|----------|----------|----------|
| 8 core | Potentiometer | 5V | Grounding | Grounding | Signal 1 | Signal 2 | Signal 3 | Signal 4 |

Note: The interface of control board should be completely consistent with the interface of the keypad panel.











so the line sequence should also be the same.

- The default remote-control wire length is 1m. The length of remote-control wire can be custom-made by users. If on the occasion of strong interference or the length is longer than 3m, please put a magnetic ring on the wire to avoid interference.



### 3.3 Panel Operating

All keys on the panel are available for user. Refer to Table 3-3 for their functions.

Table 3-3 **Uses of Keys**

| Keys                                                                              | Names              | Remarks                                                                                                          |
|-----------------------------------------------------------------------------------|--------------------|------------------------------------------------------------------------------------------------------------------|
|  | Fun                | To call function code and switch over display mode.                                                              |
|  | Set                | To call and save data.                                                                                           |
|  | Up                 | To increase data (speed control or setting parameters)                                                           |
|  | Down               | To decrease data (speed control or setting parameters)                                                           |
|  | Run                | To start inverter;                                                                                               |
|  | Stop or reset      | To stop inverter; to reset in fault status; to change function codes in a code group or between two code groups. |
|  | Multi-function key | FWD/REV jogging and LOC/REM control is selected by multi-function key.                                           |
|  | Forward or reverse | Switchover of motor forward/reverse running                                                                      |
|  | Shift key          | Shift and displaying items switchover.                                                                           |

#### Operating structure of four-line LCD:















The display interface of keypad will turn to malfunction interface when inverter trips into fault. User can check current, voltage and frequency by pressing . The specific values will be displayed on the fourth line of malfunction interface if the malfunction code is displayed as anyone of OC, OC1, OE, OL1 and OL2. “?A”, “?V” and “?Hz” for current, voltage and frequency respectively will be displayed if malfunction code is not one of above 6 malfunctions. User can check malfunction type and status of second (third) –to-last by pressing . After clearing the faults, keypad cannot response reset function but only shift function when pressing Reset/Stop key in non-malfunction interface; keypad can response reset function when pressing Reset/Stop key only in malfunction interface.

### 3.4 Parameters Setting

This inverter has numerous function parameters, which the user can modify to effect different modes of operation control. User needs to realize that if user sets password valid (F107=1), user’s password must be

entered first if parameters are to be set after power off or protection is effected, i.e., to call F100 as per the mode in Table 2-2 and enter the correct code. User's password is invalid before delivery, and user could set corresponding parameters without entering password.

**Table 3-2 Steps for Parameters Setting**

| Steps | Keys                                                                                                                                                                   | Operation                                                        | Display                                                                           |
|-------|------------------------------------------------------------------------------------------------------------------------------------------------------------------------|------------------------------------------------------------------|-----------------------------------------------------------------------------------|
| 1     |                                                                                       | Press "Fun" key to display function code                         |  |
| 2     |  or  | Press "Up" or "Down" to select required function code            |  |
| 3     |                                                                                       | To read data set in the function code                            |  |
| 4     |  or  | To modify data                                                   |  |
| 5     |                                                                                       | To display corresponding function code after saving the set data |  |
|       |                                                                                       | To display the current function code                             |  |

The above-mentioned step should be operated when inverter is in stop status.

### 3.5 Function Codes Switchover in/between Code-Groups

It has more than 300 parameters (function codes) available to user, divided into 10 sections as indicated in Table 3-3.

**Table 3-3 Function Code Partition**

| Group Name                               | Function Code Range | Group Name                  | Function Code Range |
|------------------------------------------|---------------------|-----------------------------|---------------------|
| Basic Parameters                         | F1                  | Parameters of the motor     | F8                  |
| Run Control Mode                         | F2                  | Communication function      | F9                  |
| Multi-functional input/output terminal   | F3                  | PID parameter setting       | FA                  |
| Analog signals and pulse of input/output | F4                  | Torque control              | FC                  |
| Multi-stage speed parameters             | F5                  | The second motor parameters | FE                  |
| Subsidiary function                      | F6                  | IO expansion                | FF                  |
| Timing control and protection function   | F7                  | Parameters display          | H0                  |

As parameters setting costs time due to numerous function codes, such function is specially designed as "Function Code Switchover in a Code Group or between Two Code-Groups" so that parameters setting become convenient and simple.

Press “Fun” key so that the keypad controller will display function code. If press “▲” or “▼” key then, function code will circularly keep increasing or decreasing by degrees within the group; if press the “stop/reset” key again, function code will change circularly between two code groups when operating the “▲” or “▼” key.

e.g. when function code shows F111 and DGT indicator is on, press “▲”/ “▼” key, function code will keep increasing or decreasing by degrees within F100~F160; press “stop/reset” key again, DGT indicator will be off. When pressing “▲”/ “▼” key, function codes will change circularly among the 10 code-groups, like F211, F311...FA11, F111..., Refer to Fig 2-2 (The sparkling “50.00” is indicated the corresponding target frequency values).

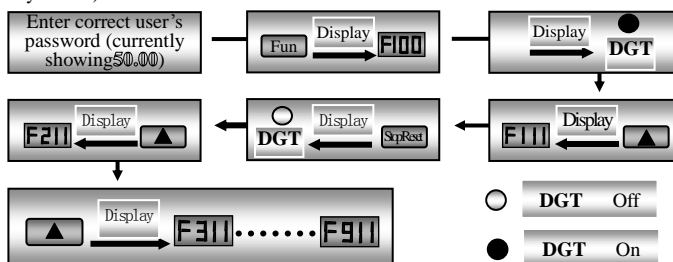

Fig 3-6 Switch over in a Code Group or between Different Code-Groups

### 3.6 Panel Display

Table 3-4 Items and Remarks Displayed on the Panel

| Items                                                                  | Remarks                                                                                                                                                                                                                                                                                                           |
|------------------------------------------------------------------------|-------------------------------------------------------------------------------------------------------------------------------------------------------------------------------------------------------------------------------------------------------------------------------------------------------------------|
| Power on....<br>(Four-line LCD)                                        | It stands for power on process.                                                                                                                                                                                                                                                                                   |
| HF-0                                                                   | This Item will be displayed when you press “Fun” in stopping status, which indicates jogging operation is valid. But HF-0 will be displayed only after you change the value of F132.                                                                                                                              |
| -HF-                                                                   | It stands for resetting process and will display target frequency after reset.                                                                                                                                                                                                                                    |
| OC, OC1, OC2, OE,<br>OL1, OL2, OH, LU,<br>PF0, PF1,CE, PG,<br>STO,STO1 | Fault code, indicating “over-current OC”, “over-current OC1”, “over-current OC2”, “over-voltage”, “inverter over-load”, “motor over-load” “over-heat”, “under-voltage for input”, “phase loss for output”, “phase loss for input”, “communication error”, PG disconnection protection, STO and STO1 respectively. |
| AErr, EP, nP, Err5                                                     | Analog line disconnected, inverter under-load, pressure control, PID parameters are set wrong.                                                                                                                                                                                                                    |
| ovEr, br1, br2                                                         | (textile industry) yarn full, yarn broken, yarn intertwinning.                                                                                                                                                                                                                                                    |
| ESP                                                                    | During two-line/three line running mode, “stop/reset” key is pressed or external emergency stop terminal is closed, ESP will be displayed.                                                                                                                                                                        |

## E2000

|                  |                                                                                                      |
|------------------|------------------------------------------------------------------------------------------------------|
| oPEn             | When oPEn terminal is invalid, inverter will trip into oPEn protection.                              |
| F152             | Function code (parameter code).                                                                      |
| 10.00            | Indicating inverter's current running frequency (or rotate speed) and parameter setting values, etc. |
| 50.00            | Sparkling in stopping status to display target frequency.                                            |
| A100, U100, u540 | Output current (100A) and output voltage (100V) and bus voltage(540V).                               |
| b*.*             | PID feedback value is displayed.                                                                     |
| o*.*             | PID given value is displayed.                                                                        |
| L***             | Linear speed is displayed.                                                                           |
| H ***            | Radiator temperature is displayed.                                                                   |

## IV. Installation & Connection

### 4.1 Installation

Inverter should be installed vertically, as shown in Fig 4-1. Sufficient ventilation space should be ensured in its surrounding.

Clearance dimensions (recommended) are available from Table 4-1 for installing the inverter.

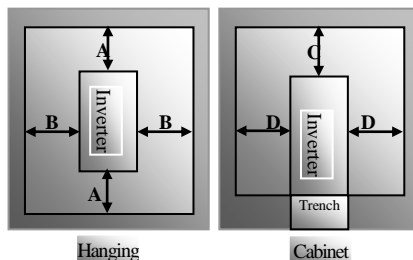

Fig 4-1 Installation Sketch

Table 4-1 Clearance Dimensions

| Model                          | Clearance Dimensions  |                       |
|--------------------------------|-----------------------|-----------------------|
| Hanging (<55kW)                | $A \geq 150\text{mm}$ | $B \geq 100\text{mm}$ |
| Hanging ( $\geq 55\text{kW}$ ) | $A \geq 200\text{mm}$ | $B \geq 100\text{mm}$ |
| Cabinet (110~800kW)            | $C \geq 200\text{mm}$ | $D \geq 100\text{mm}$ |

### 4.2 Connection

- In case of 3-phase input, connect R/L1, S/L2 and T/L3 terminals (L1/R and L2/S terminals for single-phase) with power source from network and PE/E to earthing, U, V and W terminals to motor.
- Motor shall have to be ground connected. Or else electrified motor causes interference.

Power terminals sketch of inverter with 1-phase 230V 1.5kW and below 1.5kW.

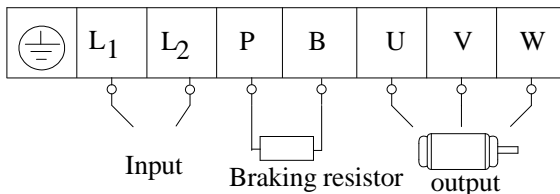

Power terminals sketch of inverter with 3-phase 230V 1.5kW and below 1.5kW.

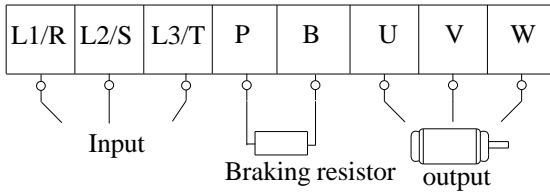

Power terminals sketch of inverter with 1-phase 230V 2.2kW, 3-phase 230V 2.2kW~5.5 kW, and 3-phase 400V 0.75kW~15kW.

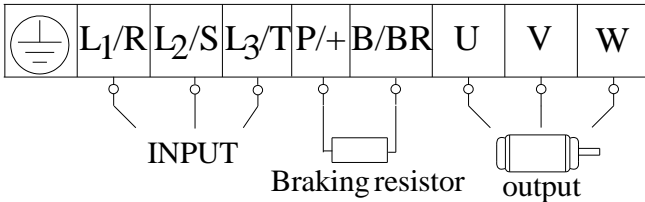

Power terminals sketch of inverter with 3-phase 230V 7.5~11kW and three-phase 400V 18.5kW~45kW.

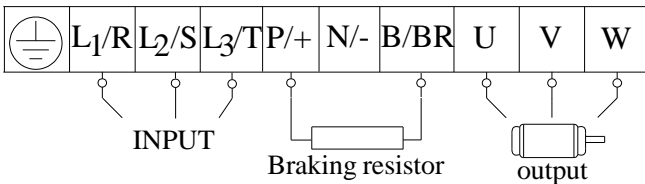

Power terminals sketch of inverter with 3-phase 230V 15~75kW and 3-phase 400V 55kW~180kW hanging type inverter and 110kW~160kW cabinet inverter.

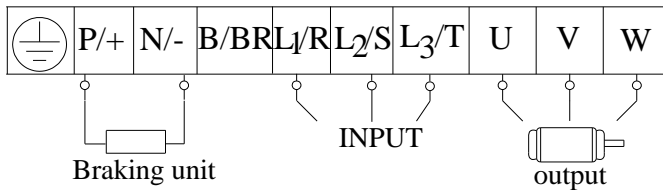

Power terminals sketch of inverter with 3-phase 200kw~400kw hanging type inverter and 180kw~800kw cabinet inverter.

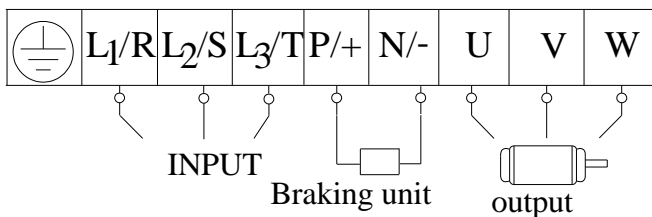

(The figure is only sketch, terminals order of practical products may be different from the above-mentioned figure.)

### Introduction of terminals of power loop

| Terminals            | Terminal Marking | Terminal Function Description                                                                                                                                                                |
|----------------------|------------------|----------------------------------------------------------------------------------------------------------------------------------------------------------------------------------------------|
| Power Input Terminal | L1/R, L2/S, L3/T | Input terminals of three-phase 400V AC voltage (L1/R and L2/S terminals for 1-phase)                                                                                                         |
| Output Terminal      | U, V, W          | Inverter power output terminal, connected to motor.                                                                                                                                          |
| Grounding Terminal   | PE/E/⊕           | Inverter grounding terminal.                                                                                                                                                                 |
| Rest Terminal        | P/+, B/BR        | External braking resistor.                                                                                                                                                                   |
|                      | P/+, N/-         | DC bus-line output<br>Externally connected to braking unit<br>P/+ connected to input terminal “P” or “DC+” of braking unit,<br>N/- connected to input terminal of braking unit “N” or “DC-”. |

### 4.3 Functions of control terminals

The key to operate the inverter is to operate the control terminals correctly and flexibly. Certainly, the control terminals are not operated separately, and they should match corresponding settings of parameters. This chapter describes basic functions of the control terminals. The users may operate the control terminals by combining relevant contents hereafter about “Defined Functions of the Terminals”.

**Wiring for control loop as follows:**

|     |    |    |     |     |     |    |     |     |     |     |     |     |     |     |     |     |     |     |     |     |
|-----|----|----|-----|-----|-----|----|-----|-----|-----|-----|-----|-----|-----|-----|-----|-----|-----|-----|-----|-----|
| TA  | TB | TC | DO1 | DO2 | 24V | CM | DI1 | DI2 | DI3 | DI4 | DI5 | DI6 | DI7 | DI8 | 10V | AI1 | AI2 | GND | AO1 | AO2 |
| GND | 5V | A+ | B-  |     |     |    |     |     |     |     |     |     |     |     |     |     |     |     |     |     |

Table 4-3

Functions of Control Terminals

| Terminal              | Type                | Description                                                                                                  | Function                                                                                                                                                                                                                                                                                                                                                                                                                                                                                   |                                                                                                                                                  |
|-----------------------|---------------------|--------------------------------------------------------------------------------------------------------------|--------------------------------------------------------------------------------------------------------------------------------------------------------------------------------------------------------------------------------------------------------------------------------------------------------------------------------------------------------------------------------------------------------------------------------------------------------------------------------------------|--------------------------------------------------------------------------------------------------------------------------------------------------|
| DO1                   | Output signal       | Multifunctional output terminal 1                                                                            | When the token function is valid, the value between this terminal and CM is 0V; when the inverter is stopped, the value is 24V. When DO1 is as high-frequency output terminal, the max output frequency is 100KHz and please do not connect to intermediate relay.                                                                                                                                                                                                                         | The functions of output terminals shall be defined per manufacturer’s value. Their initial state may be changed through changing function codes. |
| DO2 <sup>Note 1</sup> |                     | Multifunctional output terminal 2                                                                            | When the token function is valid, the value between this terminal and CM is 0V; when the inverter is stopped, the value is 24V.                                                                                                                                                                                                                                                                                                                                                            |                                                                                                                                                  |
| TA                    |                     | Relay contact                                                                                                | TC is a common point, TB-TC are normally closed contacts, TA-TC are normally open contacts. The contact capacity is 10A/125VAC, NO/NC 3A 250VAC/30VDC.                                                                                                                                                                                                                                                                                                                                     |                                                                                                                                                  |
| TB                    |                     |                                                                                                              |                                                                                                                                                                                                                                                                                                                                                                                                                                                                                            |                                                                                                                                                  |
| TC                    |                     |                                                                                                              |                                                                                                                                                                                                                                                                                                                                                                                                                                                                                            |                                                                                                                                                  |
| AO1                   |                     | Voltage/current output                                                                                       | It is connected with frequency meter, speedometer or ammeter externally, and its minus pole is connected with GND. See F423~F426 for details,.                                                                                                                                                                                                                                                                                                                                             |                                                                                                                                                  |
| AO2                   | Current output      | It is connected with ammeter externally, and its minus pole is connected with GND. See F427~F430 for details |                                                                                                                                                                                                                                                                                                                                                                                                                                                                                            |                                                                                                                                                  |
| 10V                   | Analog power supply | Self contained power supply                                                                                  | Internal 10V self-contained power supply of the inverter provides power to the inverter. When used externally, it can only be used as the power supply for voltage control signal, with current restricted below 20mA.                                                                                                                                                                                                                                                                     |                                                                                                                                                  |
| AI1 <sup>Note 2</sup> | Input Signal        | Voltage analog input port                                                                                    | When analog speed control is adopted, the voltage or current signal is input through this terminal. The range of voltage input is 0~5V or 0~10V or -10V~10V, and the current input is 0~20mA, the input resistor is 500Ohm, and grounding: GND. If the input is 4~20mA, it can be realized by setting F406=2. The voltage or current signal can be chosen by coding switch. See table 5-2, 5-3 for details, the default setting of AI1 is 0~10V, and the default setting of AI2 is 0~20mA. |                                                                                                                                                  |
| AI2                   |                     | Voltage / Current analog input port                                                                          |                                                                                                                                                                                                                                                                                                                                                                                                                                                                                            |                                                                                                                                                  |
| GND                   |                     | Self-contained Power supply Ground                                                                           | Ground terminal of external control signal (voltage control signal or current source control signal) is also the ground of 10V power supply of this inverter.                                                                                                                                                                                                                                                                                                                              |                                                                                                                                                  |
| 24V                   | Power supply        | Control power supply                                                                                         | Power: 24±1.5V, grounding is CM; current is restricted below 200mA for external use.                                                                                                                                                                                                                                                                                                                                                                                                       |                                                                                                                                                  |



|                       |                                |                                          |                                                                                                                                                                                                                                                           |                                                                                                                                             |
|-----------------------|--------------------------------|------------------------------------------|-----------------------------------------------------------------------------------------------------------------------------------------------------------------------------------------------------------------------------------------------------------|---------------------------------------------------------------------------------------------------------------------------------------------|
| DI1                   | Digital input control terminal | Jogging terminal                         | When this terminal is valid, the inverter will have jogging running. The jogging function of this terminal is valid under both at stopped and running status. This terminal can also be used as high-speed pulse input port. The max frequency is 100KHz. | The functions of input terminals shall be defined per manufacturer's value. Other functions can also be defined by changing function codes. |
| DI2                   |                                | External Emergency Stop                  | When this terminal is valid, "ESP" malfunction signal will be displayed.                                                                                                                                                                                  |                                                                                                                                             |
| DI3                   |                                | "FWD" Terminal                           | When this terminal is valid, inverter will run forward.                                                                                                                                                                                                   |                                                                                                                                             |
| DI4                   |                                | "REV" Terminal                           | When this terminal is valid, inverter will run reversely.                                                                                                                                                                                                 |                                                                                                                                             |
| DI5                   |                                | Reset terminal                           | Make this terminal valid under fault status to reset the inverter.                                                                                                                                                                                        |                                                                                                                                             |
| DI6                   |                                | Free-stop                                | Make this terminal valid during running can realize free stop.                                                                                                                                                                                            |                                                                                                                                             |
| DI7 <sup>Note 1</sup> |                                | Running terminal                         | When this terminal is in the valid state, inverter will run by the acceleration time.                                                                                                                                                                     |                                                                                                                                             |
| DI8 <sup>Note 1</sup> |                                | Stop terminal                            | Make this terminal valid during running can realize stop by the deceleration time.                                                                                                                                                                        |                                                                                                                                             |
| CM                    | Common port                    | Grounding of control power supply        | The grounding of 24V power supply and other control signals.                                                                                                                                                                                              |                                                                                                                                             |
| GND                   | 485 communication terminals    | Grounding of differential signal         | Grounding of differential signal                                                                                                                                                                                                                          |                                                                                                                                             |
| 5V                    |                                | Power of differential signal             | Power of differential signal                                                                                                                                                                                                                              |                                                                                                                                             |
| A+                    |                                | Positive polarity of differential signal | Standard: TIA/EIA-485(RS-485)<br>Communication protocol: Modbus                                                                                                                                                                                           |                                                                                                                                             |
| B-                    |                                | Negative polarity of Differential signal | Communication rate: 1200/2400/4800/9600/19200/38400/57600bps                                                                                                                                                                                              |                                                                                                                                             |

**Note:**

1. T3 30kW and below 30kW and T2 11kw and below 11kw inverters have no DO2, DI7 and DI8 control terminals.
2. All terminal of T3 30kW and below 30kW and T2 11kw and below 11kw inverters can only accept voltage signal, the default voltage is 0~10V.

**Wiring for digital input terminals:**

Generally, shield cable is adopted and wiring distance should be as short as possible. When active signal is adopted, it is necessary to take filter measures to prevent power supply interference. Mode of contact control is recommended.

Digital input terminals are only connected by source electrode (NPN mode) or by drain electrode (PNP mode). If NPN mode is adopted, please turn the toggle switch to the end of "NPN".

Wiring for control terminals as follows:

**1. Wiring for positive source electrode (NPN mode).**

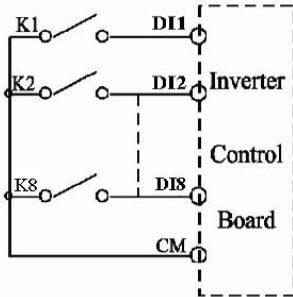

**2. Wiring for active source electrode**

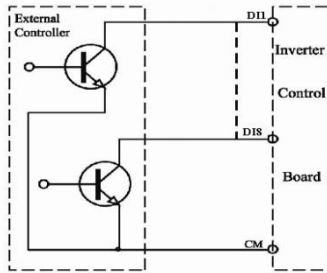

If digital input control terminals are connected by drain electrode, please turn the toggle switch to the end of “PNP”. Wiring for control terminals as follows:

**3. Wiring for positive drain electrode (PNP mode)**

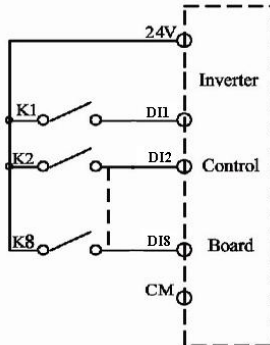

#### 4. Wiring for active drain electrode (PNP mode)

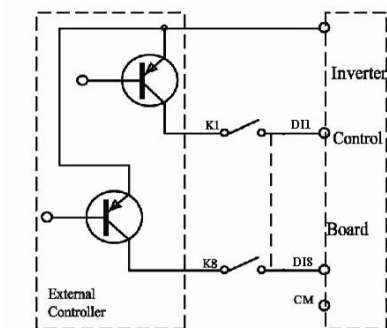

Wiring by source electrode is a mode most in use at present. Wiring for control terminal is connected by source electrode, user should choose wiring mode according to requirement.

##### Instructions of choosing NPN mode or PNP mode:

1. There is a toggle switch J7 near to control terminals. Please refer to Fig 3-2.
2. When turning J7 to “NPN”, DI terminal is connected to CM.  
When turning J7 to “PNP”, DI terminal is connected to 24V.



Fig 4-2 Toggle Switch J7

### 4.4 Measurement of main circuit voltages, currents and powers

Since the voltages and currents on the inverter power supply and output sides include harmonics, measurement data depends on the instruments used and circuits measured. When instruments for commercial frequency are used for measurement, measure the following circuits with the recommended instruments.

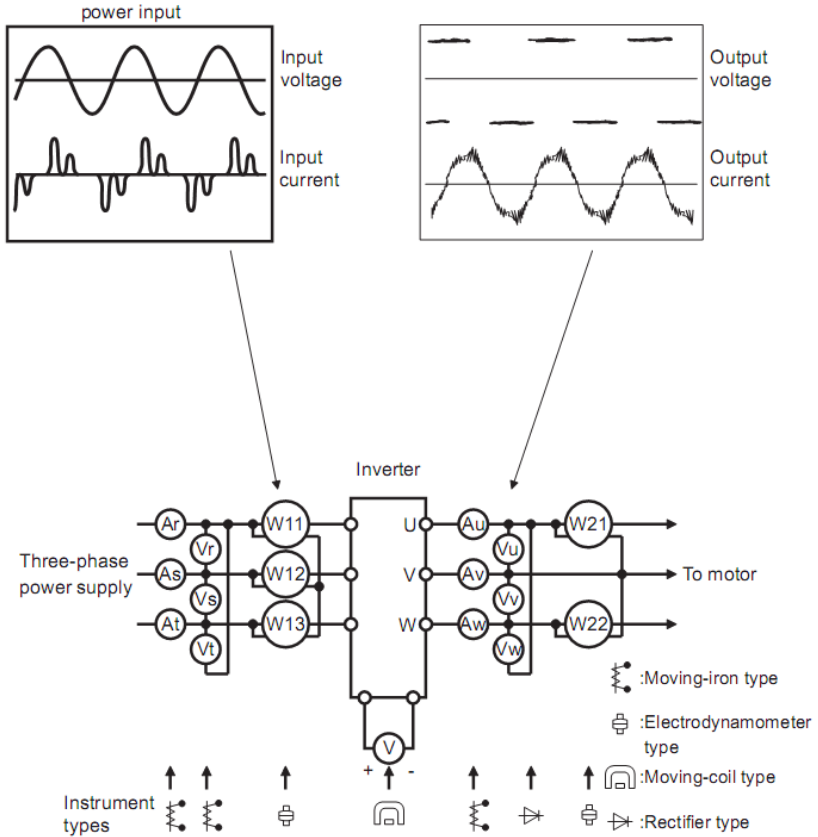

**Examples of Measuring Points and Instruments**

| Item                               | Measuring Point                                                                                                                                                                          | Measuring Instrument                                          | Remarks (Reference Measurement Value)                                                                                                        |
|------------------------------------|------------------------------------------------------------------------------------------------------------------------------------------------------------------------------------------|---------------------------------------------------------------|----------------------------------------------------------------------------------------------------------------------------------------------|
| Power supply voltage V1            | Across R-S,S-T, T-R                                                                                                                                                                      | Moving-iron type AC voltmeter                                 | 400V $\pm$ 5%, 230V $\pm$ 5%                                                                                                                 |
| Power supply side current I1       | R, S, and T line currents                                                                                                                                                                | Moving-iron type AC voltmeter                                 |                                                                                                                                              |
| Power supply side power P1         | At R, S and T, and across R-S, S-T and T-R                                                                                                                                               | Electrodynamic type single-phase wattmeter                    | P1=W11+W12+W13 (3-wattmeter method)                                                                                                          |
| Power supply side power factor Pf1 | Calculate after measuring power supply voltage, power supply side current and power supply side power.[Three phase power supply]<br>$Pf1 = \frac{P1}{\sqrt{3}V1 \times I1} \times 100\%$ |                                                               |                                                                                                                                              |
| Output side voltage V2             | Across U-V, V-W and W-U                                                                                                                                                                  | Rectifier type AC voltmeter (Moving-iron type cannot measure) | Difference between the phases is within $\pm$ 1% of the maximum output voltage.                                                              |
| Output side current I2             | U, V and W line currents                                                                                                                                                                 | Moving-iron type AC Ammeter                                   | Current should be equal to or less than rated inverter current. Difference between the phases is 10% or lower of the rated inverter current. |
| Output side power P2               | U, V, W and U-V, V-W,W-U                                                                                                                                                                 | Electrodynamic type single-phase wattmeter                    | P2 = W21 + W22<br>2-wattmeter method                                                                                                         |
| Output side power factor Pf2       | Calculate in similar manner to power supply side power factor:<br>$Pf2 = \frac{P2}{\sqrt{3}V2 \times I2} \times 100\%$                                                                   |                                                               |                                                                                                                                              |
| Converter output                   | Across P+ (P) and -(N)                                                                                                                                                                   | Moving-coil type (such as multi-meter)                        | DC voltage, the value is $\sqrt{2} \times V1$                                                                                                |
| Power supply of control PCB        | Across 10V-GND                                                                                                                                                                           | Moving-coil type (such as multi-meter)                        | DC10V $\pm$ 0.2V                                                                                                                             |
|                                    | Across 24V-CM                                                                                                                                                                            | Moving-coil type (such as multi-meter)                        | DC24V $\pm$ 1.5V                                                                                                                             |
| Analog output AO1                  | Across AO1-GND                                                                                                                                                                           | Moving-coil type (such as multi-meter)                        | Approx. DC10V at max frequency.                                                                                                              |
|                                    | Across AO2-GND                                                                                                                                                                           | Moving-coil type (such as multi-meter)                        | Approx. DC 4~20mA at max frequency                                                                                                           |
| Alarm signal                       | Across TA/TC<br>Across TB/TC                                                                                                                                                             | Moving-coil type (such as multi-meter)                        | <Normal> <Abnormal><br>Across<br>TA/TC: Discontinuity<br>Continuity Across<br>TB/TC: Continuity<br>Discontinuity                             |

## 4.5 Wiring Recommended

| Inverter Model | Lead Section Area(mm <sup>2</sup> ) | Inverter Model | Lead Section Area(mm <sup>2</sup> ) |
|----------------|-------------------------------------|----------------|-------------------------------------|
| E2000-0004S2   | 1.5                                 | E2000-0075T3   | 4.0                                 |
| E2000-0007S2   | 2.5                                 | E2000-0110T3   | 6.0                                 |
| E2000-0015S2   | 2.5                                 | E2000-0150T3   | 10                                  |
| E2000-0022S2   | 4.0                                 | E2000-0185T3   | 16                                  |
| E2000-0002T2   | 1.5                                 | E2000-0220T3   | 16                                  |
| E2000-0004T2   | 1.5                                 | E2000-0300T3   | 25                                  |
| E2000-0007T2   | 2.5                                 | E2000-0370T3   | 25                                  |
| E2000-0015T2   | 2.5                                 | E2000-0450T3   | 35                                  |
| E2000-0022T2   | 4.0                                 | E2000-0550T3   | 35                                  |
| E2000-0030T2   | 4.0                                 | E2000-0750T3   | 50                                  |
| E2000-0040T2   | 4.0                                 | E2000-0900T3   | 70                                  |
| E2000-0055T2   | 6.0                                 | E2000-1100T3   | 70                                  |
| E2000-0075T2   | 10                                  | E2000-1320T3   | 95                                  |
| E2000-0110T2   | 16                                  | E2000-1600T3   | 120                                 |
| E2000-0150T2   | 25                                  | E2000-1800T3   | 120                                 |
| E2000-0185T2   | 25                                  | E2000-2000T3   | 150                                 |
| E2000-0220T2   | 25                                  | E2000-2200T3   | 185                                 |
| E2000-0300T2   | 35                                  | E2000-2500T3   | 240                                 |
| E2000-0370T2   | 50                                  | E2000-2800T3   | 240                                 |
| E2000-0450T2   | 50                                  | E2000-3150T3   | 300                                 |
| E2000-0550T2   | 70                                  | E2000-3550T3   | 300                                 |
| E2000-0750T2   | 95                                  | E2000-4000T3   | 400                                 |
| E2000-0007T3   | 1.5                                 | E2000-4500T3   | 480                                 |
| E2000-0015T3   | 2.5                                 | E2000-5000T3   | 520                                 |
| E2000-0022T3   | 2.5                                 | E2000-5600T3   | 560                                 |
| E2000-0030T3   | 2.5                                 | E2000-6300T3   | 720                                 |
| E2000-0040T3   | 2.5                                 | E2000-7100T3   | 780                                 |
| E2000-0055T3   | 4.0                                 | E2000-8000T3   | 900                                 |

## 4.6 Lead section area of protect conductor (grounding wire)

| Lead section area S of U, V, W (mm <sup>2</sup> ) | Min lead section area of $\oplus/1\phi$<br>/PE/E(mm <sup>2</sup> ) |
|---------------------------------------------------|--------------------------------------------------------------------|
| S ≤ 16                                            | S                                                                  |
| 16 < S ≤ 35                                       | 16                                                                 |
| 35 < S                                            | S/2                                                                |

## 4.7 Overall Connection and “Three- Line” Connection

\* Refer to next figure for overall connection sketch for E2000 series inverters. Wiring mode is available for various terminals whereas not every terminal needs connection when applied.

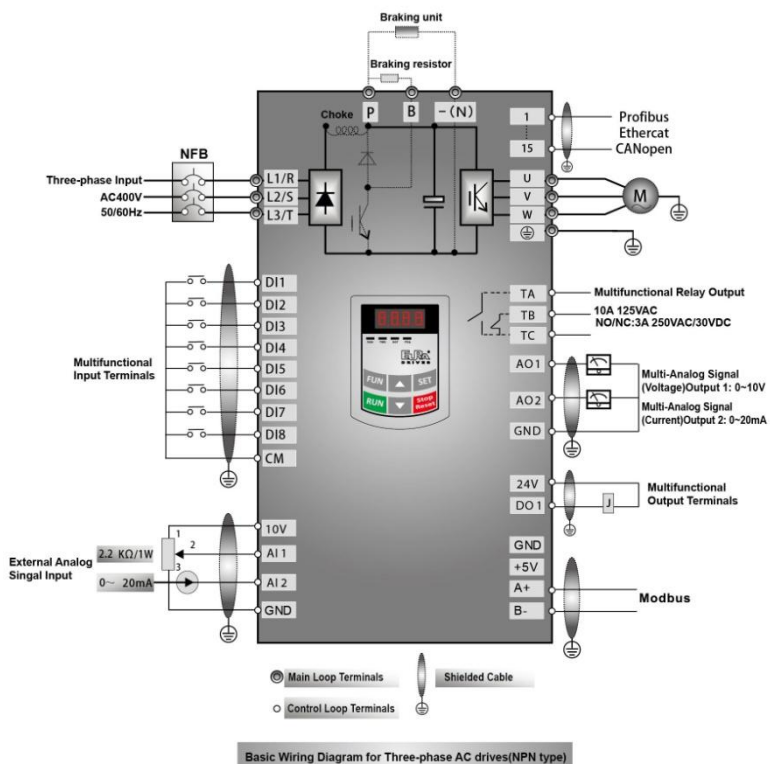

Note:

1. Please only connect power terminals L1/R and L2/S with power grid for single-phase inverters.
2. 485 communication port has built-in standard MODBUS communication protocol. Communication port is on the left side of inverter. The sequence from top to down is B-, A+, 5V power, and GND.
3. Inverter above 30kW has 8 multifunctional input terminals DI1~DI8, 30kW inverter and below 30kW has 6 multifunctional input terminals DI1~DI6.
4. The contact capacity is 10A/125VAC. NO/NC: 3A 250VAC/30VDC.

## 4.8 Basic methods of suppressing the noise

The noise generated by the drive may disturb the equipment nearby. The degree of disturbance is dependent on the drive system, immunity of the equipment, wiring, installation clearance and earthing methods.

### 4.8.1 Noise propagation paths and suppressing methods

#### ① Noise categories

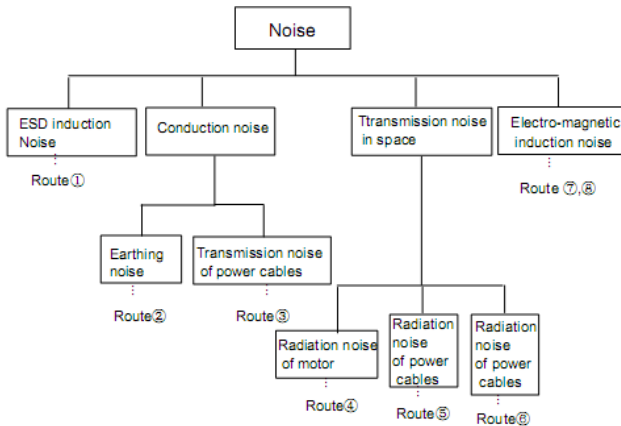

#### ② Noise propagation paths

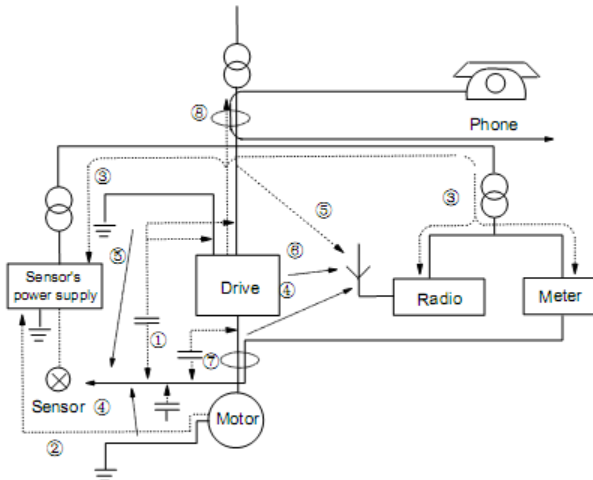



## ③ Basic methods of suppressing the noise

| Noise emission paths | Actions to reduce the noise                                                                                                                                                                                                                                                                                                                                                                                                                                                                                                                                                                                                                                                                                                                                                                                                                                                                                                                                                                                                     |
|----------------------|---------------------------------------------------------------------------------------------------------------------------------------------------------------------------------------------------------------------------------------------------------------------------------------------------------------------------------------------------------------------------------------------------------------------------------------------------------------------------------------------------------------------------------------------------------------------------------------------------------------------------------------------------------------------------------------------------------------------------------------------------------------------------------------------------------------------------------------------------------------------------------------------------------------------------------------------------------------------------------------------------------------------------------|
| ②                    | When the external equipment forms a loop with the drive, the equipment may suffer nuisance tripping due to the drive's earth leakage current. The problem can be solved if the equipment is not grounded.                                                                                                                                                                                                                                                                                                                                                                                                                                                                                                                                                                                                                                                                                                                                                                                                                       |
| ③                    | If the external equipment shares the same AC supply with the drive, the drive's noise may be transmitted along its input power supply cables, which may cause nuisance tripping to other external equipment. Take the following actions to solve this problem: Install noise filter at the input side of the drive, and use an isolation transformer or line filter to prevent the noise from disturbing the external equipment.                                                                                                                                                                                                                                                                                                                                                                                                                                                                                                                                                                                                |
| ④⑤⑥                  | If the signal cables of measuring meters, radio equipment and sensors are installed in a cabinet together with the drive, these equipment cables will be easily disturbed. Take the actions below to solve the problem:<br>(1) The equipment and the signal cables should be as far away as possible from the drive. The signal cables should be shielded and the shielding layer should be grounded. The signal cables should be placed inside a metal tube and should be located as far away as possible from the input/output cables of the drive. If the signal cables must cross over the power cables, they should be placed at right angle to one another.<br>(2) Install radio noise filter and linear noise filter (ferrite common-mode choke) at the input and output of the drive to suppress the emission noise of power lines.<br>(3) Motor cables should be placed in a tube thicker than 2mm or buried in a cement conduit. Power cables should be placed inside a metal tube and be grounded by shielding layer |
| ①⑦⑧                  | Don't route the signal cables in parallel with the power cables or bundle these cables together because the induced electro-magnetic noise and induced ESD noise may disturb the signal cables. Other equipment should also be located as far away as possible from the drive. The signal cables should be placed inside a metal tube and should be placed as far away as possible from the input/output cables of the drive. The signal cables and power cables should be shielded cables. EMC interference will be further reduced if they could be placed inside metal tubes. The clearance between the metal tubes should be at least 20cm.                                                                                                                                                                                                                                                                                                                                                                                 |

## 4.8.2 Field Wire Connections

Control cables, input power cables and motor cables should be installed separately, and enough clearance should be left among the cables, especially when the cables are laid in parallel and the cable length is big. If the signal cables must go through the power cables, they should be vertical to each other.

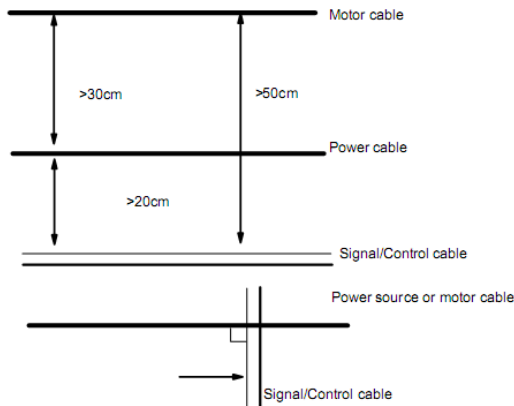

Generally, the control cables should be shielded cables and the shielding metal net must be connected to the metal enclosure of the drive by cable clamps.

### 4.8.3 Earthing

Independent earthing poles (best)

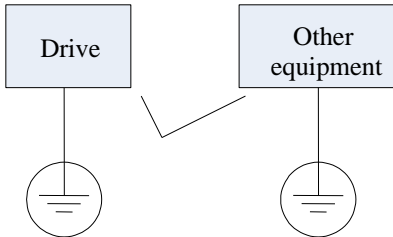

Shared earthing pole (good)

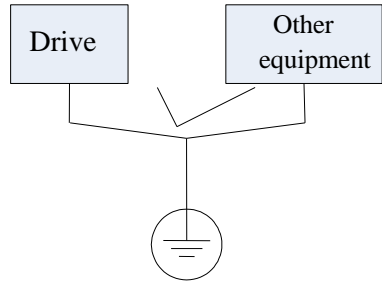

Shared earthing cable (not good)

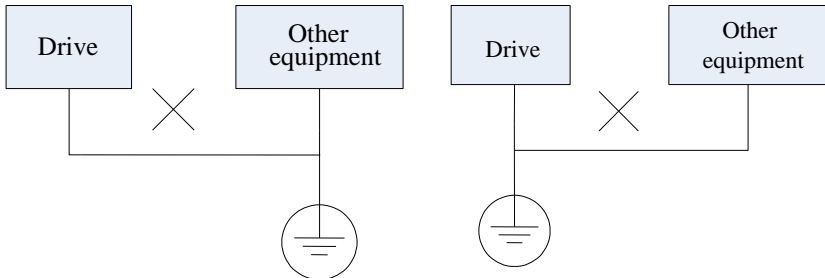

#### Note:

1. In order to reduce the earthing resistance, flat cable should be used because the high frequency impedance of flat cable is smaller than that of round cable with the same CSA.
2. If the earthing poles of different equipment in one system are connected together, then the leakage current will be a noise source that may disturb the whole system. Therefore, the drive's earthing pole should be separated with the earthing pole of other equipment such as audio equipment, sensors and PC, etc.
3. Earthing cables should be as far away from the I/O cables of the equipment that is sensitive to noise, and also should be as short as possible.

### 4.8.4 Leakage current

Leakage current may flow through the drive's input and output capacitors and the motor's capacitor. The leakage current value is dependent on the distributed capacitance and carrier wave frequency. The leakage current includes ground leakage current and the leakage current between lines.

Ground leakage current

---

The ground leakage current can not only flow into the drive system, but also other equipment via earthing cables. It may cause the leakage current circuit breaker and relays falsely activated. The higher the drive's carrier wave frequency, the bigger the leakage current, also, the longer the motor cable, the greater the leakage current,

Suppressing methods:

- Reduce the carrier wave frequency, but the motor noise may be louder;

- Motor cables should be as short as possible;

- The drive and other equipment should use leakage current circuit breaker designed for protecting the product against high-order harmonics/surge leakage current;

Leakage current between lines

The line leakage current flowing through the distribution capacitors of the drive out side may cause the thermal relay falsely activated, especially for the drive whose power is lower than 7.5kW. When the cable is longer than 50m, the ratio of leakage current to motor rated current may be increased that can cause the wrong action of external thermal relay very easily.

Suppressing methods:

- Reduce the carrier wave frequency, but the motor noise may become louder;

- Install reactor at the output side of the drive.

In order to protect the motor reliably, it is recommended to use a temperature sensor to detect the motor's temperature, and use the drive's over-load protection device (electronic thermal relay) instead of an external thermal relay.

#### **4.8.5 Electrical installation of the drive**

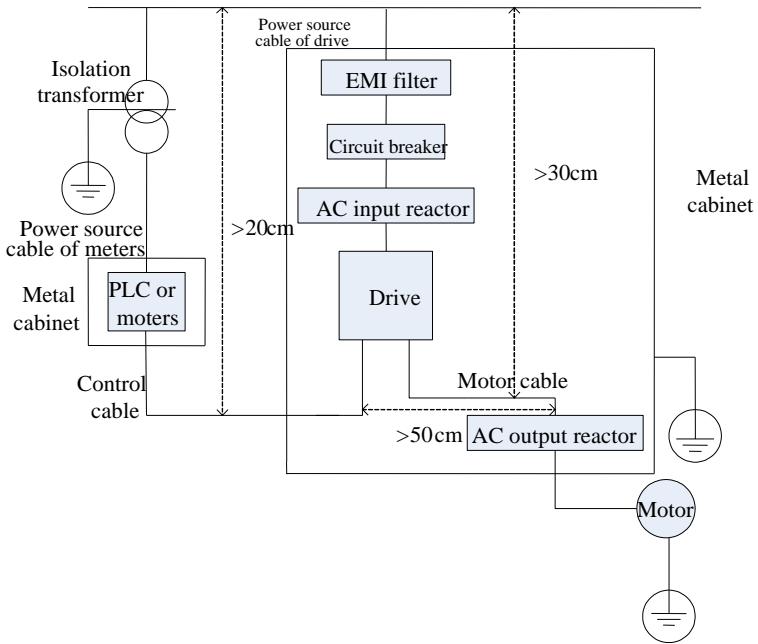
**Note:**

Motor cable should be earthed at the drive side, if possible, the motor and drive should be earthed separately; Motor cable and control cable should be shielded. The shield must be earthed and avoid entangling at cable end to improve high frequency noise immunity.

Assure good conductivity among plates, screw and metal case of the drive; use tooth-shape washer and conductive installation plate;

**4.8.6 Application of Power Line Filter**

Power source filter should be used in the equipment that may generate strong EMI or the equipment that is sensitive to the external EMI. The power source filter should be a two-way low pass filter through which only 50Hz current can flow and high frequency current should be rejected.

Function of power line filter

The power line filter ensures the equipment can satisfy the conducting emission and conducting sensitivity in EMC standard. It can also suppress the radiation of the equipment.

Common mistakes in using power cable filter

1. Too long power cable

The filter inside the cabinet should be located near to the input power source. The length of the power cables should be as short as possible.

2. The input and output cables of the AC supply filter are too close

The distance between input and output cables of the filter should be as far apart as possible, otherwise the high frequency noise may be coupled between the cables and bypass the filter. Thus, the filter will become ineffective.

3. Bad earthing of filter

The filter's enclosure must be earthed properly to the metal case of the drive. In order to be earthed well, make use of a special earthing terminal on the filter's enclosure. If you use one cable to connect the filter to the case, the earthing is useless for high frequency interference. When the frequency is high, so is the impedance of cable, hence there is little bypass effect. The filter should be mounted on the enclosure of equipment. Ensure to clear away the insulation paint between the filter case and the enclosure for good earthing contact.

## V. Operation and Simple Running

This chapter defines and interprets the terms and nouns describing the control, running and status of the inverter. Please read it carefully. It will be helpful to your correct operation.

### 5.1 Basic conception

#### 5.1.1 Control mode

E2000 inverter has five control modes: sensorless vector control (F106=0), closed-loop vector control (F106=1), V/F control (F106=2) and vector control 1 (F106=3), PMSM vector control (F106=6).

#### 5.1.2 Mode of torque compensation

Under V/F control mode, E2000 inverter has five kinds of torque compensation modes: Linear compensation (F137=0); Square compensation (F137=1); User-defined multipoint compensation (F137=2); Auto torque compensation (F137=3); VF separation (F137=4).

#### 5.1.3 Mode of frequency setting

Please refer to F203~F207 for the method for setting the running frequency of the E2000 inverter.

#### 5.1.4 Mode of controlling for running command

The channel for inverter to receive control commands (including start, stop and jogging, etc) contains three modes: 1. Keypad (keypad panel) control; 2. External terminal control; 3. Communication control. The modes of control command can be selected through the function codes F200 and F201.

#### 5.1.5 Operating status of inverter

When the inverter is powered on, it may have four kinds of operating status: stopped status, programming status, running status, and fault alarm status. They are described in the following:

##### Stopped status

If re-energize the inverter (if “auto-startup after being powered on” is not set) or decelerate the inverter to stop, the inverter is at the stopping status until receiving control command. At this moment, the running status indicator on the keypad goes off, and the display shows the display status before power down.

##### Programming status

Through keypad panel, the inverter can be switched to the status that can read or change the function code parameters. Such a status is the programming status.

There are numbers of function parameters in the inverter. By changing these parameters, the user can realize different control modes.

##### Running status

The inverter at the stopped status or fault-free status will enter running status after having received operation command.

The running indicator on keypad panel lights up under normal running status.

##### Fault alarm status

The status under which the inverter has a fault and the fault code is displayed.

Fault codes mainly include: OC, OE, OL1, OL2, OH, LU, PF1 and PF0 representing “over current”, “over voltage”, “inverter overload”, “motor overload”, “overheat”, “input under-voltage”, “input phase loss”, and “output phase loss” respectively.

For trouble shooting, please refer to Appendix I to this manual, “Trouble Shooting”.

## 5.2 Keypad panel and operation method

Keypad panel (keypad) is a standard part for configuration of E2000 inverter. Through keypad panel, the user may carry out parameter setting, status monitoring and operation control over the inverter. Both keypad panel and display screen are arranged on the keypad controller, which mainly consists of three sections: data display section, status indicating section, and keypad operating section. There are two types of keypad controller (LED and four-line LCD) for inverter. For details, please refer to Chapter II of this manual, “Keypad panel”.

It is necessary to know the functions and how to use the keypad panel. Please read this manual carefully before operation.

### 5.2.1 Method of operating the keypad panel

(1) Operation process of setting the parameters through keypad panel









A three-level menu structure is adopted for setting the parameters through keypad panel of inverter, which enables convenient and quick searching and changing of function code parameters.

Three-level menu: Function code group (first-level menu) → Function code (second-level menu) → Set value of each function code (third-level menu).





(2) Setting the parameters

Setting the parameters correctly is a precondition to give full play of inverter performance. The following is the introduction on how to set the parameters through keypad panel.

LED keypad operating procedures:

- ① Press the “Fun” key, to enter programming menu.
- ② Press the key “Stop/Reset” or , the DGT lamp goes out. Press  and , the function code will change within the function code group. The first number behind F displayed on the panel is 1, in other words, it displays F1 ××at this moment.
- ③ Press the key “Stop/Reset” or , again, the DGT lamp lights up, and the function code will change within the code group. Press  and  to change the function code to F113; press the “Set” key to display 50.00; while press  and  to change to the need frequency.
- ④ Press the “Set” key to complete the change.

#### The operation of four-line LCD:

When function code shows F100 and the last “0” in F100 is flashing, after pressing  key, the middle “0” is flashing, then press  again, “1” in F100 is flashing, the flashing value can be changed by pressing “”/“” key.

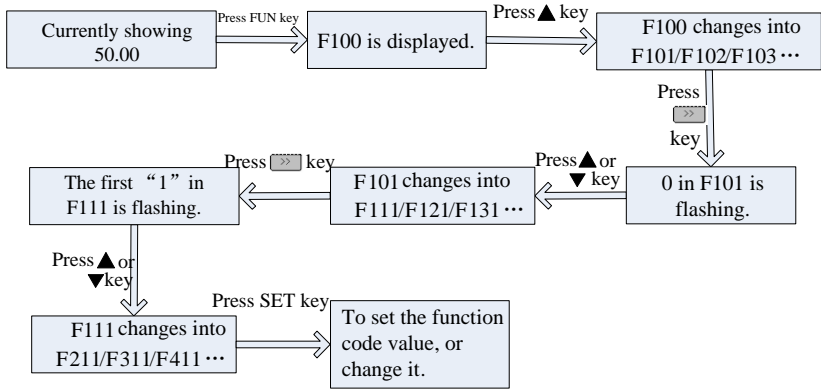

Fig 5-1 Switch over in a Code Group or between Different Code-Groups

**Operating instructions of 4-line LCD interface switch**

**① Operating instructions of SET/FUN keys**

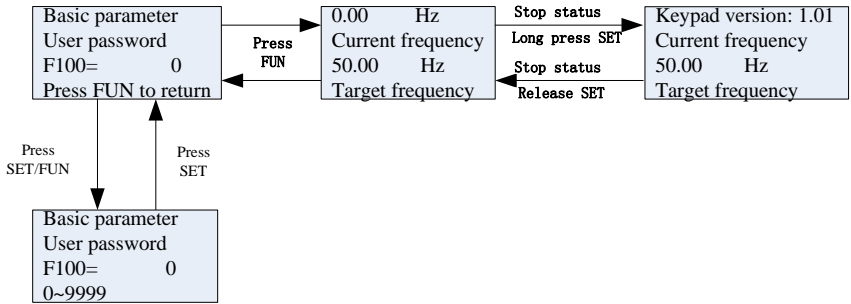

Fig 5-2 Operating flow chart of interface switch

**② Operating instructions of multifunction key**



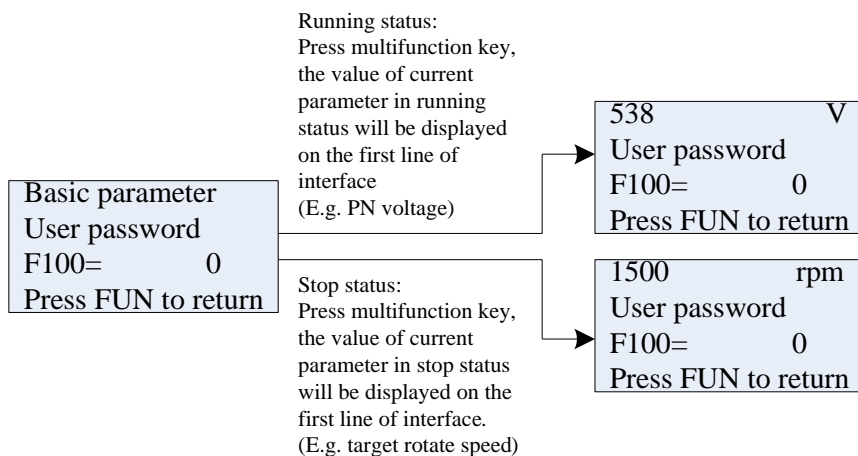

Fig 5-3 Operating flow chart of programming

### ③ Operating instructions of inverter status display

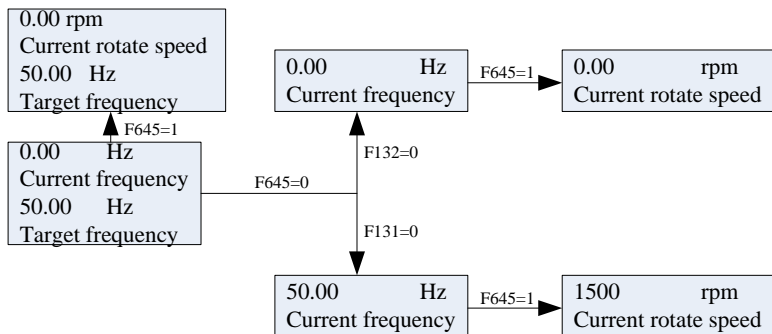

Fig 5-4 Operating flow chart of status parameter display

### ④ Regulating target frequency/target rotate speed by UP/DOWN keys in running status

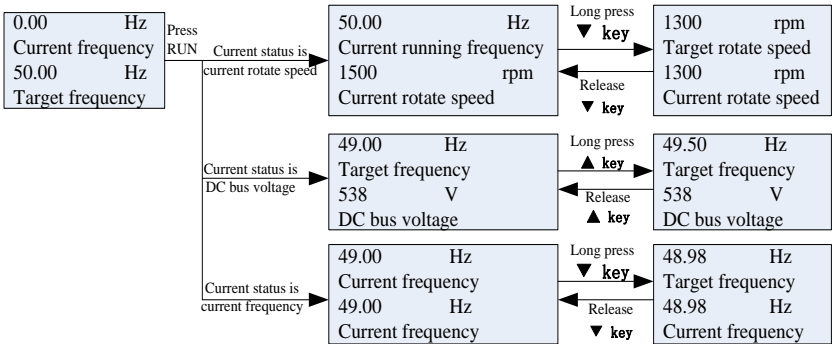

Fig 5-5 Operating flow chart of target frequency/rotate speed adjustments

⑤ Operating instructions of displayed malfunction interface

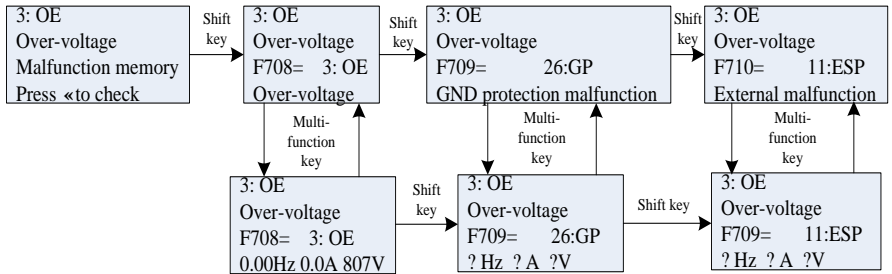

Fig 5-6 Operating flow chart of displayed malfunction interface

5.2.2 Switching and displaying of status parameters

Under stopped status or running status, LED digitron and four-line LCD of inverter can display status parameters of the inverter. Actual parameters displayed can be selected and set through function codes F131 and F132. Through the “Fun” key, it can switch over repeatedly and display the parameters of stopped status or running status. The followings are the description of operation method of displaying the parameters under stopped status and running status.

(1) Switching of the parameters displayed under stopped status

Under stopped status, inverter has several parameters of stopped status, which can be switched over repeatedly and displayed with the keys “Fun” and “Stop/Reset”. These parameters are displayed: keypad jogging, target rotary speed, PN voltage, PID feedback value, temperature, PID given value and count value. Please refer to the description of function code F132.

(2) Switching of the parameters displayed under running status

Under running status, several parameters of running status can be switched over repeatedly and displayed with the keys “Fun”. These parameters are displayed: output rotary speed, output current, output voltage, PN voltage, PID feedback value, temperature, count value, linear speed and PID given value. Please refer to the description of function code F131.

### 5.2.3 Operation process of measuring motor parameters

The user shall input the parameters accurately as indicated on the nameplate of the motor prior to selecting operation mode of vector control and auto torque compensation (F137=3) of V/F control mode. Inverter will match standard motor stator resistance parameters according to these parameters indicated on the nameplate. To achieve better control performance, the user may start the inverter to measure the motor stator resistance parameters, so as to obtain accurate parameters of the motor controlled.

The motor parameters can be tuned through function code F800.

For example: If the parameters indicated on the nameplate of the motor controlled are as follows: numbers of motor poles are 4; rated power is 7.5kW; rated voltage is 400V; rated current is 15.4A; rated frequency is 50.00HZ; and rated rotary speed is 1440rpm, operation process of measuring the parameters shall be done as described in the following:

1. In accordance with the above motor parameters, set the values of F801 to F805 correctly: set the value of F801 = 7.5, F802 = 400, F803 = 15.4, F804 = 4 and F805 = 1440 respectively.
2. In order to ensure dynamic control performance of the inverter, set F800=1, i.e. select rotating tuning. Make sure that the motor is disconnected from the load. Press the “Run” key on the keypad, and the LED keypad will display “TEST”, four-line of LCD will display “parameters measurement...” and it will tune the motor’s parameters of two stages. After that, the motor will accelerate according to the acceleration time set at F114 and maintain for a certain period. The speed of motor will then decelerate to 0 according to the time set at F115. After auto-checking is completed, relevant parameters of the motor will be stored in function codes F806~F809, and F800 will turn to 0 automatically. In closed-loop vector control mode, please set F851 according to encoder, the unit is P/R.
3. If it is impossible to disconnect the motor from the load, select F800=2, i.e. stationary tuning. Press the “Run” key, the LED keypad will display “TEST”, four-line of LCD will display “parameters measurement...” and it will tune the motor’s parameters of two stages. The motor’s stator resistance, rotor resistance and leakage inductance will be stored in F806-F808 automatically, and F800 will turn to 0 automatically. The user may also calculate and input the motor’s mutual inductance value manually according to actual conditions of the motor.

### 5.2.4 Operation process of simple running

**Table 5-1 Brief Introduction to Inverter Operation Process**

| Process                                | Operation                                                                                                                                                                                                                                                                               | Reference                    |
|----------------------------------------|-----------------------------------------------------------------------------------------------------------------------------------------------------------------------------------------------------------------------------------------------------------------------------------------|------------------------------|
| Installation and operation environment | Install the inverter at a location meeting the technical specifications and requirements of the product. Mainly take into consideration the environment conditions (temperature, humidity, etc) and heat radiation of the inverter, to check whether they can satisfy the requirements. | See Chapters I, II, III, IV. |

|                                                                                                              |                                                                                                                                                                                                                                                                                                                                                                                                                                                                                                                                                                                                                                                      |                                              |
|--------------------------------------------------------------------------------------------------------------|------------------------------------------------------------------------------------------------------------------------------------------------------------------------------------------------------------------------------------------------------------------------------------------------------------------------------------------------------------------------------------------------------------------------------------------------------------------------------------------------------------------------------------------------------------------------------------------------------------------------------------------------------|----------------------------------------------|
| Wiring of the inverter                                                                                       | Wiring of input and output terminals of the main circuit; wiring of grounding; wiring of switching value control terminal, analog terminal and communication interface, etc.                                                                                                                                                                                                                                                                                                                                                                                                                                                                         | See Chapter IV.                              |
| Checking before getting energized                                                                            | Make sure that the voltage of input power supply is correct; the input power supply loop is connected with a breaker; the inverter has been grounded correctly and reliably; the power cable is connected to the power supply input terminals of inverter correctly (R/L1, S/L2 terminals for single-phase power grid, and R/L1, S/L2, and T/L3 for three-phase power grid); the output terminals U, V, and W of the inverter are connected to the motor correctly; the wiring of control terminals is correct; all the external switches are preset correctly; and the motor is under no load (the mechanical load is disconnected from the motor). | See Chapters 1~IV                            |
| Checking immediately after energized                                                                         | Check if there is any abnormal sound, fuming or foreign flavor with the inverter. Make sure that the display of keypad panel is normal, without any fault alarm message. In case of any abnormality, switch off the power supply immediately.                                                                                                                                                                                                                                                                                                                                                                                                        | See Appendix 1 and Appendix 2.               |
| Inputting the parameters indicated on the motor's nameplate correctly, and measuring the motor's parameters. | Make sure to input the parameters indicated on the motor nameplate correctly, and study the parameters of the motor. The users shall check carefully, otherwise, serious problems may arise during running. Before initial running with vector control mode, carry out tuning of motor parameters, to obtain accurate electric parameters of the motor controlled. Before carrying out tuning of the parameters, make sure to disconnect the motor from mechanical load, to make the motor under entirely no load status. It is prohibited to measure the parameters when the motor is at a running status.                                          | See description of parameter group F800~F830 |
| Setting running control parameters                                                                           | Set the parameters of the inverter and the motor correctly, which mainly include target frequency, upper and lower frequency limits, acceleration/deceleration time, and direction control command, etc. The user can select corresponding running control mode according to actual applications.                                                                                                                                                                                                                                                                                                                                                    | See description of parameter group.          |
| Checking under no load                                                                                       | With the motor under no load, start the inverter with the keypad or control terminal. Check and confirm running status of the drive system.<br>Motor's status: stable running, normal running, correct rotary direction, normal acceleration/deceleration process, free from abnormal vibration, abnormal noise and foreign flavor.<br>Inverter's status: normal display of the data on keypad panel, normal running of the fan, normal acting sequence of the relay, free from the abnormalities like vibration or noise.<br>In case of any abnormality, stop and check the inverter immediately.                                                   | See Chapter V.                               |
| Checking under with load                                                                                     | After successful test run under no load, connect the load of drive system properly. Start the inverter with the keypad or control terminal, and increase the load gradually. When the load is increased to 50% and 100%, keep the inverter run for a period respectively, to check if the system is running normally. Carry out overall inspection over the inverter during running, to check if there is any abnormality. In case of any abnormality,                                                                                                                                                                                               |                                              |

|                         |                                                                                                                                                                                                                                                                                                                                                                                                                                                                                                                   |  |
|-------------------------|-------------------------------------------------------------------------------------------------------------------------------------------------------------------------------------------------------------------------------------------------------------------------------------------------------------------------------------------------------------------------------------------------------------------------------------------------------------------------------------------------------------------|--|
|                         | stop and check the inverter immediately.                                                                                                                                                                                                                                                                                                                                                                                                                                                                          |  |
| Checking during running | Check if the motor is running stably, if the rotary direction of the motor is correct, if there is any abnormal vibration or noise when the motor is running, if the acceleration/deceleration process of the motor is stable, if the output status of the inverter and the display of keypad panel is correct, if the blower fan is run normally, and if there is any abnormal vibration or noise. In case of any abnormality, stop the inverter immediately, and check it after switching off the power supply. |  |

### 5.3 Illustration of basic operation

Illustration of inverter basic operation: we hereafter show various basic control operation processes by taking a 7.5kW inverter that drives a 7.5kW three-phase asynchronous AC motor as an example.

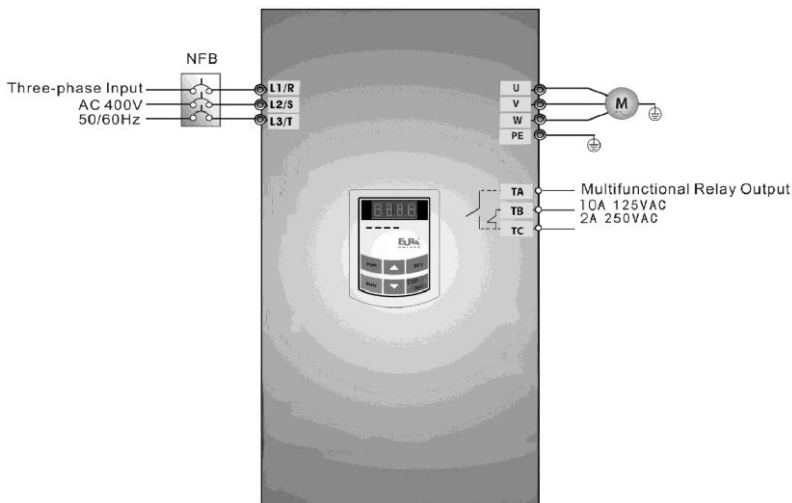

Figure 5-7 Wiring Diagram 1

The parameters indicated on the nameplate of the motor are as follows: 4 poles; rated power, 7.5kW; rated voltage, 400V; rated current, 15.4A; rated frequency 50.00HZ; and rated rotary speed, 1440rpm.

### 5.3.1 Operation process of frequency setting, start, forward running and stop with keypad panel

- (1) Connect the wires in accordance with Figure 5-7. After having checked the wiring successfully, switch on the air switch, and power on the inverter.
- (2) Press the “Fun” key, to enter the programming menu.
- (3) Measure the parameters of the motor

| Function code | Values |
|---------------|--------|
| F800          | 1(2)   |
| F801          | 7.5    |
| F802          | 400    |
| F803          | 15.4   |
| F805          | 1440   |

Press the “Run” key, to measure the parameters of the motor. After completion of the tuning, the motor will stop running, and relevant parameters will be stored in F806~F809. For the details of tuning of motor parameters, please refer to “Operation process of measuring the motor parameters” in this manual and Chapter XII of this manual. (Note: F800=1 is rotating tuning, F800=2 is stationary tuning. In the mode of rotating tuning, make sure to disconnect the motor from the load).

- (4) Set functional parameters of the inverter:

| Function code | Values |
|---------------|--------|
| F111          | 50.00  |
| F200          | 0      |
| F201          | 0      |
| F202          | 0      |
| F203          | 0      |

- (5) Press the “Run” key, to start the inverter;
- (6) During running, current frequency of the inverter can be changed by pressing ▲ or ▼;
- (7) Press the “Stop/Reset” key once, the motor will decelerate until it stops running;
- (8) Switch off the air switch, and power off the inverter.

### 5.3.2 Operation process of setting the frequency with keypad panel, and starting, forward and reverse running, and stopping inverter through control terminals

- (1) Connect the wires in accordance with Figure 5-2. After having checked the wiring successfully, switch on the air switch, and power on the inverter;

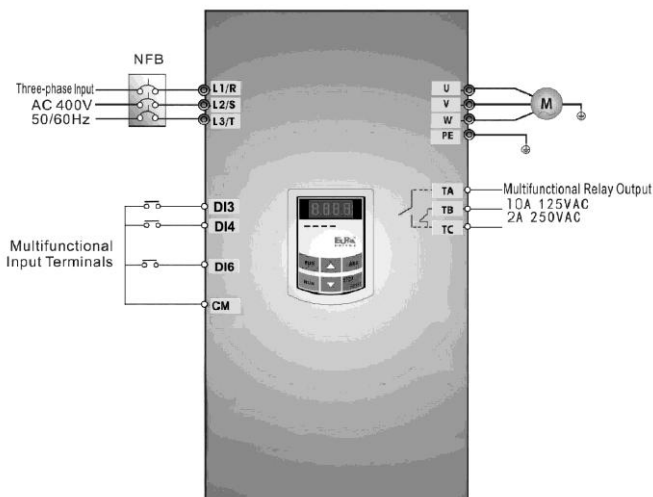

**Figure 5-8 Wiring Diagram 2**

- (2) Press the “Fun” key, to enter the programming menu.
- (3) Study the parameters of the motor: the operation process is the same as that of example 1.
- (4) Set functional parameters of the inverter:

| Function code | Values |
|---------------|--------|
| F111          | 50.00  |
| F203          | 0      |
| F208          | 1      |

- (5) Close the switch DI3, the inverter starts forward running;
- (6) During running, current frequency of the inverter can be changed by pressing ▲ or ▼;
- (7) During running, switch off the switch DI3, then close the switch DI4, the running direction of the motor will be changed (Note: The user should set the dead time of forward and reverse running F120 on the basis of the load. If it was too short, OC protection of the inverter may occur.)
- (8) Switch off the switches DI3 and DI4, the motor will decelerate until it stops running;
- (9) Switch off the air switch, and power off the inverter.

### 5.3.3 Operation process of jogging operation with keypad panel

Jogging operation includes two ways.

The first way is as below:

- (1) Connect the wires in accordance with Figure 5-7. After having checked the wiring successfully, switch on the air switch, and power on the inverter;
- (2) Press the “Fun” key, to enter the programming menu.

- (3) Study the parameters of the motor: the operation process is the same as that of example 1.  
 (4) Set functional parameters of the inverter:  
 LED keypad parameters setting:

| Function code | Values |
|---------------|--------|
| F124          | 5.00   |
| F125          | 30     |
| F126          | 30     |
| F132          | 1      |
| F202          | 0      |

- (5) Press and hold the “Run” key until the motor is accelerated to the jogging frequency, and maintain the status of jogging operation.  
 (6) Release the “Run” key, and the motor will decelerate until jogging operation is stopped;  
 (7) Switch off the air switch, and power off the inverter.

The second way is as below:

- (1) Connect the wires in accordance with Figure 5-7. After having checked the wiring successfully, switch on the air switch, and power on the inverter;  
 (2) Press the “Fun” key, to enter the programming menu.  
 (3) Study the parameters of the motor: the operation process is the same as that of example 1.  
 (4) Set functional parameters of the inverter:

LED keypad parameters setting:

| Function code | Values |
|---------------|--------|
| F124          | 5.00   |
| F125          | 30     |
| F126          | 30     |
| F132          | 1      |
| F643          | 1      |

Four-line LCD parameters setting:

| Function code | Values |
|---------------|--------|
| F124          | 5.00   |
| F125          | 30     |
| F126          | 30     |
| F643          | 1      |

- (5) When the keypad is LED, press and hold the “Run” key until the motor is accelerated to the jogging frequency, and maintain the status of jogging operation. When the keypads is LCD, press and hold the multifunction key until the motor is accelerated to the jogging frequency, and maintain the status of jogging operation. If F643=2, motor will reverse jogging.  
 (6) Release the “Run” key(LED keypad) or multifunction key (LCD keypad). The motor will decelerate until jogging operation is stopped;  
 (7) Switch off the air switch, and power off the inverter.



### 5.3.4 Operation process of setting the frequency with analog terminal and controlling the operation with control terminals

(1) Connect the wires in accordance with Figure 5-9. After having checked the wiring successfully, switch on the air switch, and power on the inverter. Note: 2K~5K potentiometer may be adopted for setting external analog signals. For the cases with higher requirements for precision, please adopt precise multiturn potentiometer, and adopt shielded wire for the wire connection, with near end of the shielding layer grounded reliably.

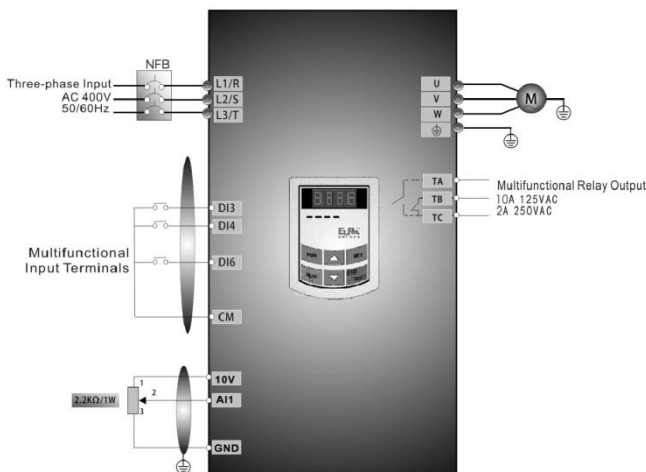

Figure 5-9 Wiring Diagram 3

- (2) Press the “Fun” key, to enter the programming menu.
- (3) Study the parameters of the motor: the operation process is the same as that of example 1.
- (4) Set functional parameters of the inverter:

| Function code | Values |
|---------------|--------|
| F203          | 1      |
| F208          | 1      |

(5) There is a red two-digit coding switch SW1 near the control terminal block of 22 kW inverter and below 22 kW, as shown in Figure 5-10. The function of coding switch is to select the voltage signal (0~5V/0~10V) or current signal of analog input terminal AI2, current channel is default. In actual application, select the analog input channel through F203. Turn switches 1 to ON and 2 to ON as illustrated in the figure, and select 0~20mA current speed control. Another switches states and mode of control speed are as table 5-2.

(6) There is a red four-digit coding switch SW1 near the control terminal block of above 30 kW inverter, as shown in Figure 5-11. The function of coding switch is to select the input range (0~5V/0~10V/0~20mA) of analog input terminal AI1 and AI2. In actual application, select the analog input

channel through F203. AI1 channel default value is 0~10V, AI2 channel default value is 0~20mA. Another switches states and mode of control speed are as table 5-3.

(7) There is a toggle switch S1 at the side of control terminals, please refer to Fig 5-12. S1 is used to select the voltage input range of AI1 channel. When turning S1 to “+”, the input range is 0~10V, when turning S1 to “-”, the input range is -10~10V.

(8) Close the switch DI3, the motor starts forward running;

(9) The potentiometer can be adjusted and set during running, and the current setting frequency of the inverter can be changed;

(10) During running process, switch off the switch DI3, then, close DI4, the running direction of the motor will be changed;

(11) Switch off the switches DI3 and DI4, the motor will decelerate until it stops running;

(12) Switch off the air switch, and power off the inverter.

(13) Analog output terminal AO2 can only output current signal, AO1 terminal can output voltage and current signal, the selecting switch is J5, please refer to Fig 5-13, the output relation is shown in table 5-4.

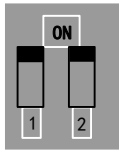

SW1

Fig 5-10

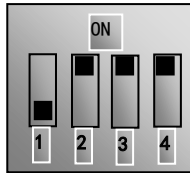

SW1

Fig 5-11

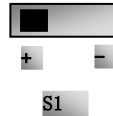

S1

Fig 5-12

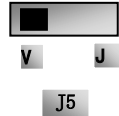

J5

Fig 5-13

**Table 5-2 The Setting of Coding Switch and Parameters in the Mode of Analog Speed Control**

| F203=2, channel AI2 is selected |                 |                       | F203=1, channel AI1 is selected |                 |
|---------------------------------|-----------------|-----------------------|---------------------------------|-----------------|
| SW1 coding switch               |                 |                       | S1 toggle switch                |                 |
| Coding Switch 1                 | Coding Switch 2 | Mode of Speed Control | +                               | -               |
| OFF                             | OFF             | 0~5V voltage          | 0~10V voltage                   | -10~10V voltage |
| OFF                             | ON              | 0~10V voltage         |                                 |                 |
| ON                              | ON              | 0~20mA current        |                                 |                 |

**Table 5-3 The Setting of Coding Switch and Parameters in the Mode of Analog Speed Control**

| Set F203 to 1, to select channel AI1 |          |                  |                     | Set F203 to 2, to select channel AI2 |          |                     |
|--------------------------------------|----------|------------------|---------------------|--------------------------------------|----------|---------------------|
| Coding Switch SW1                    |          | Toggle switch S1 | Analog signal range | Coding Switch SW1                    |          |                     |
| Switch 1                             | Switch 3 |                  |                     | Switch 2                             | Switch 4 | Analog signal range |
| OFF                                  | OFF      | +                | 0~5V voltage        | OFF                                  | OFF      | 0~5V voltage        |
| OFF                                  | ON       | +                | 0~10V voltage       | OFF                                  | ON       | 0~10V voltage       |
| ON                                   | ON       | +                | 0~20mA current      | ON                                   | ON       | 0~20mA current      |
| OFF                                  | OFF      | -                | Reserved            |                                      |          |                     |
| OFF                                  | ON       | -                | -10~10V voltage     |                                      |          |                     |
| ON                                   | ON       | -                | Reserved            |                                      |          |                     |

ON refers to switching the coding switch to the top, OFF refers to switching the coding switch to the bottom

**Table 5-4 The relationship between AO1 and J5 and F423**

| AO1 output |   | Setting of F423 |        |          |
|------------|---|-----------------|--------|----------|
|            |   | 0               | 1      | 2        |
| J5         | V | 0~5V            | 0~10V  | Reserved |
|            | I | Reserved        | 0~20mA | 4~20mA   |

## VI. Function Parameters

### 6.1 Basic parameters

|      |                 |                       |                |
|------|-----------------|-----------------------|----------------|
| F100 | User's Password | Setting range: 0~9999 | Mfr's value: 0 |
|------|-----------------|-----------------------|----------------|

·When F107=1 with valid password, the user must enter correct user's password after power on or fault reset if you intend to change parameters. Otherwise, parameter setting will not be possible, and a prompt "Err1" will be displayed on the LED keypad, and "password is incorrect" will be displayed on the LCD keypad.

Relating function code: F107 Password valid or not F108 Setting user's password

|      |                              |  |                                        |
|------|------------------------------|--|----------------------------------------|
| F102 | Inverter's Rated Current (A) |  | Mfr's value: Subject to inverter model |
| F103 | Inverter Power (kW)          |  | Mfr's value: Subject to inverter model |
| F104 | Voltage level                |  | Mfr's value: Subject to inverter model |

·Rated current, rated power and voltage level can only be checked but cannot be modified.

|      |                      |                           |                                        |
|------|----------------------|---------------------------|----------------------------------------|
| F105 | Software Edition No. | Setting range: 1.00~10.00 | Mfr's value: Subject to inverter model |
|------|----------------------|---------------------------|----------------------------------------|

Software Edition No. can only be checked but cannot be modified.

|      |              |                                                                                                                                                                 |                |
|------|--------------|-----------------------------------------------------------------------------------------------------------------------------------------------------------------|----------------|
| F106 | Control mode | Setting range:<br>0:Sensorless vector control (SVC);<br>1: Closed-loop vector control (VC);<br>2: V/F; 3: Vector control 1<br>6: PMSM sensorless vector control | Mfr's value: 2 |
|------|--------------|-----------------------------------------------------------------------------------------------------------------------------------------------------------------|----------------|

0: Sensorless vector control is suitable for the application of high-performance requirement. One inverter can only drive one motor.

1: Closed-loop vector control is suitable for the application of high-precision speed control and torque control. One inverter can only drive one motor, and the motor must install encoder. Encoder must be installed, and please set F851 and F854 correctly.

2: V/F control is suitable for common requirement of control precision or one inverter drives several motors.

3: Vector control 1 is auto torque promotion, which has the same function of F137=3. While studying motor parameters, motor does not need to be disconnected with load. One inverter can only drive one motor.

6: PMSM sensorless vector control is suitable for the application of high-performance requirement. One inverter can only drive one motor.

Note:

1. It is necessary to study the parameters of motor before inverter runs in the vector control mode (F106=0, 1, 3 and 6).

2. Under vector control mode (F106=0, 1, 3 and 6), one inverter can only drive one motor and the power of motor should be similar to the power of inverter. Otherwise, control performance will be increased or system cannot work properly.

3. Under vector control mode (F106=0 and 1), the max frequency (F111) must be lower than

500.00Hz.

4. The operator may input motor parameters manually according to the motor parameters given by motor manufactures.

5. Usually, the motor will work normally by inverter's default parameters, but the inverter's best control performance will not be acquired. Therefore, in order to get the best control performance, please study the parameters of motor before inverter runs in the vector control mode.

|      |                         |                                     |                |
|------|-------------------------|-------------------------------------|----------------|
| F107 | Password Valid or Not   | Setting range: 0: invalid; 1: valid | Mfr's value: 0 |
| F108 | Setting User's Password | Setting range: 0~9999               | Mfr's value: 8 |

·When F107 is set to 0, the function codes can be changed without inputting the password. When F107 is set to 1, the function codes can be changed only after inputting the user's password by F100.

·The user can change "User's Password". The operation process is the same as those of changing other parameters.

· Input the value of F108 into F100, and the user's password can be unlocked.

Note: When password protection is valid, and if the user's password is not entered, F108 will display 0.

|      |                                        |                           |                   |
|------|----------------------------------------|---------------------------|-------------------|
| F109 | Starting Frequency (Hz)                | Setting range: 0.00~10.00 | Mfr's value: 0.00 |
| F110 | Holding Time of Starting Frequency (S) | Setting range: 0.0~999.9  | Mfr's value: 0.0  |

The inverter begins to run from the starting frequency. If the target frequency is lower than starting frequency, F109 is invalid.

The inverter begins to run from the starting frequency. After it keeps running at the starting frequency for the time as set in F110, it will accelerate to target frequency. The holding time is not included in acceleration/deceleration time.

Starting frequency is not limited by the Min frequency set by F112. If the starting frequency set by F109 is lower than Min frequency set by F112, inverter will start according to the setting parameters set by F109 and F110. After inverter starts and runs normally, the frequency will be limited by frequency set by F111 and F112.

Starting frequency should be lower than Max frequency set by F111.

Note: when speed track is adopted, F109 and F110 are invalid.

|      |                    |                           |                    |
|------|--------------------|---------------------------|--------------------|
| F111 | Max Frequency (Hz) | Setting range: F113~650.0 | Mfr's value: 50.00 |
| F112 | Min Frequency (Hz) | Setting range: 0.00~F113  | Mfr's value: 0.50  |

·Max frequency is set by F111.

Note: in vector control mode (F106=0,1), the max frequency should be lower than 500Hz.

·Min frequency is set by F112.

·The setting value of min frequency should be lower than target frequency set by F113.

·The inverter begins to run from the starting frequency. During running process, if the given frequency is lower than min frequency, then inverter will stop.

Max/Min frequency should be set according to the nameplate parameters and running situations of motor. The motor is forbidden running at low frequency for a long time, or else motor will be damaged because of overheat.

|      |                       |                          |                    |
|------|-----------------------|--------------------------|--------------------|
| F113 | Target Frequency (Hz) | Setting range: F112~F111 | Mfr's value: 50.00 |
|------|-----------------------|--------------------------|--------------------|

It shows the preset frequency. Under keypad speed control or terminal speed control mode, the inverter will run to this frequency automatically after startup.

|      |                             |                |                                        |
|------|-----------------------------|----------------|----------------------------------------|
| F114 | First Acceleration Time (S) | Setting range: | Mfr's value: subject to inverter model |
|------|-----------------------------|----------------|----------------------------------------|

|      |                              |          |  |
|------|------------------------------|----------|--|
| F115 | First Deceleration Time (S)  | 0.1~3000 |  |
| F116 | Second Acceleration Time (S) |          |  |
| F117 | Second Deceleration Time (S) |          |  |
| F277 | Third Acceleration Time (S)  |          |  |
| F278 | Third Deceleration Time (S)  |          |  |
| F279 | Fourth Acceleration Time (S) |          |  |
| F280 | Fourth Deceleration Time (S) |          |  |

F119 is used to set the reference of setting accel/decel time.

·The Acceleration/Deceleration time can be chosen by multifunction digital input terminals F316~F323 and connecting DI terminal with CM terminal. Please refer to the instructions of multi-functional input terminals. Note: when speed track is working, acceleration/deceleration time, min frequency and target frequency are invalid. After speed track is finished, inverter will run to target frequency according to acceleration/deceleration time.

|      |                         |                            |                    |
|------|-------------------------|----------------------------|--------------------|
| F118 | Turnover Frequency (Hz) | Setting range: 15.00~650.0 | Mfr's value: 50.00 |
|------|-------------------------|----------------------------|--------------------|

·Turnover frequency is the final frequency of V/F curve, and also is the least frequency according to the highest output voltage.

·When running frequency is lower than this value, inverter has constant-torque output. When running frequency exceeds this value, inverter has constant-power output.

Note: during the process of speed track, turnover frequency is invalid. After speed track is finished, this function code is valid.

|      |                                           |                                                   |                |
|------|-------------------------------------------|---------------------------------------------------|----------------|
| F119 | The reference of setting accel/decel time | Setting range: 0: 0~50.00Hz<br>1: 0~max frequency | Mfr's value: 0 |
|------|-------------------------------------------|---------------------------------------------------|----------------|

When F119=0, acceleration/ deceleration time means the time for inverter to accelerate/ decelerate from 0Hz (50Hz) to 50Hz (0Hz).

When F119=1, acceleration/ deceleration time means the time for inverter to accelerate/ decelerate from 0Hz (max frequency) to max frequency (0Hz).

|      |                                            |                         |                  |
|------|--------------------------------------------|-------------------------|------------------|
| F120 | Forward / Reverse Switchover dead-Time (S) | Setting range: 0.0~3000 | Mfr's value: 0.0 |
|------|--------------------------------------------|-------------------------|------------------|

· Within “forward/ reverse switchover dead-time”, this latency time will be canceled upon receiving “stop” signal. This function is suitable for all the speed control modes except automatic cycle operation.

·This function can ease the current impact in the process of direction switchover.

Note: during the process of speed track, F120 is invalid. After speed track is finished, this function code is valid.

|      |                           |                                     |                |
|------|---------------------------|-------------------------------------|----------------|
| F122 | Reverse Running Forbidden | Setting range: 0: invalid; 1: valid | Mfr's value: 0 |
|------|---------------------------|-------------------------------------|----------------|

When F122=1, inverter will only run forward no matter the state of terminals and the parameters set by F202.

Inverter will not run reverse and forward / reverse switchover is forbidden. If reverse signal is given, inverter will stop.

If reverse running locking is valid (F202=1), whatever speed track is valid or not, inverter has no output.

When F122=1, F613=1 and inverter gets forward running command and motor is sliding reverse, if inverter can detect the sliding direction and track to motor speed, then inverter will run to 0.0Hz reverse, then run forward according to the setting value of parameters.

|      |                                                                 |                      |   |
|------|-----------------------------------------------------------------|----------------------|---|
| F123 | Minus frequency is valid in the mode of combined speed control. | 0: Invalid; 1: valid | 0 |
|------|-----------------------------------------------------------------|----------------------|---|

In the mode of combined speed control, if running frequency is minus and F123=0, inverter will stop; if F123=1, inverter will run reverse at this frequency. (This function is controlled by F122.)

|                                    |                            |                                        |
|------------------------------------|----------------------------|----------------------------------------|
| F124 Jogging Frequency (Hz)        | Setting range: F112~F111   | Mfr's value: 5.00                      |
| F125 Jogging Acceleration Time (S) | Setting range:<br>0.1~3000 | Mfr's value: subject to inverter model |
| F126 Jogging Deceleration Time (S) |                            |                                        |

There are two types of jogging: keypad jogging and terminal jogging. Keypad jogging is valid only under stopped status (F132 including of displaying items of keypad jogging should be set). Terminal jogging is valid under both running status and stopped status.

Carry out jogging operation through the keypad (under stopped status):

- Press the "Fun" key, it will display "HF-0";
- Press the "Run" key, the inverter will run to "jogging frequency" (if pressing "Fun" key again, "keypad jogging" will be cancelled).

In case of terminal jogging, make "jogging" terminal (such as DI1) connected to CM, and inverter will run to jogging frequency. The rated function codes are from F316 to F323.

Note: when jogging function is valid, speed track function is invalid.

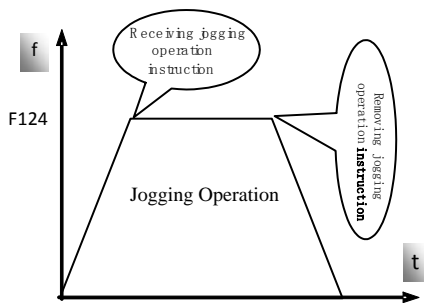

Figure 6- 1 Jogging Operation

|                                   |                           |                   |
|-----------------------------------|---------------------------|-------------------|
| F127/F129 Skip Frequency A,B (Hz) | Setting range: 0.00~650.0 | Mfr's value:0.00  |
| F128/F130 Skip Width A,B (Hz)     | Setting range: 0.00~2.50  | Mfr's value: 0.00 |

Systematic vibration may occur when the motor is running at a certain frequency. This parameter is set to skip this frequency.

The inverter will skip the point automatically when output frequency is equal to the set value of this parameter.

"Skip Width" is the span from the upper to the lower limits around Skip Frequency. For example, Skip Frequency=20Hz, Skip Width=0.5Hz, inverter will skip automatically when output is between 19.5~20.5Hz.

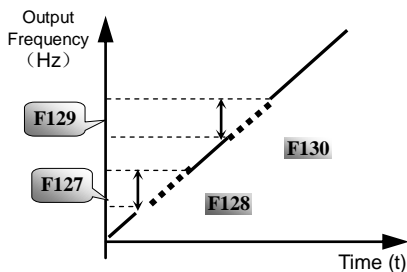

Figure 6-2 Skip Frequency

Inverter will not skip this frequency span during acceleration/deceleration.

Note: during the process of speed track, skip frequency function is invalid. After speed track is finished, this function is valid.

|                            |                                                                                                                                                                                                                                                                                                                            |                                |
|----------------------------|----------------------------------------------------------------------------------------------------------------------------------------------------------------------------------------------------------------------------------------------------------------------------------------------------------------------------|--------------------------------|
| F131 Running Display Items | 0—Current output frequency/function-code<br>1—Output rotary speed<br>2—Output current<br>4—Output voltage<br>8—PN voltage<br>16—PID feedback value<br>32—Temperature<br>64—Count values<br>128—Linear speed<br>256—PID given value<br>512—Yarn length<br>1024—Center frequency<br>2048—Output power<br>4096— Output torque | Mfr's value:<br>$0+1+2+4+8=15$ |
|----------------------------|----------------------------------------------------------------------------------------------------------------------------------------------------------------------------------------------------------------------------------------------------------------------------------------------------------------------------|--------------------------------|

Selection of one value from 1, 2, 4, 8, 16, 32, 64 and 128 shows that only one specific display item is selected. Should multiple display items be intended, add the values of the corresponding display items and take the total values as the set value of F131, e.g., just set F131 to be 19 (1+2+16) if you want to call “current output rotary speed”, “output current” and “PID feedback value”. The other display items will be covered.

As F131=8191, all display items are visible, of which, “frequency/function-code” will be visible whether or not it is selected.

Should you intend to check any display item of LED keypad, just press the “Fun” key for switchover.

Should you intend to check any display item of four-line LCD, press “Fun” key and press  key to check them.

Whatever the value of F131 is set to, corresponding target frequency will flash under stopped status.

The units and representing methods for each physical quantity in LED keypad are displayed as below:

Target rotary speed is an integral number. If it exceeds 9999, add a decimal point to it.

Current display A\*\* Voltage display U\*\*\* Count value \*\*\*\* Temperature H\*\*\*

Linear speed L\*\*\*. If it exceeds 999, add a decimal point to it. If it exceeds 9999, add two decimal points to it, and the like.

PID given value o\*\* PID feedback value b\*\* Yarn length \* center frequency \*\*

output power \*\* output torque \*\*

Note: when count value is displayed and it exceeds 9999, only 4 digits are displayed and add a decimal point to it, i.e. 12345 is displayed in the form of 1234.

In four-line LCD interface, the displayed item will be shown alternately on the fourth line of level 3 menu in F131.



|      |                              |                                                                                                                                                                                                                                                                |                         |
|------|------------------------------|----------------------------------------------------------------------------------------------------------------------------------------------------------------------------------------------------------------------------------------------------------------|-------------------------|
| F132 | Display items of stop        | Setting range: 0: Frequency/function-code<br>1: Keypad jogging<br>2: Target rotary speed<br>4: PN voltage<br>8: PID feedback value<br>16: Temperature 32: Count values<br>64: PID given value 128: Yarn length<br>256: Center frequency<br>512: Setting torque | Mfr's value:<br>0+2+4=6 |
| F133 | Drive ratio of driven system | Setting range: 0.10~200.0                                                                                                                                                                                                                                      | Mfr's value: 1.00       |
| F134 | Transmission-wheel radius    | 0.001~1.000 (m)                                                                                                                                                                                                                                                | Mfr's value: 0.001      |

Calculation of rotary speed and linear speed:

For example, If inverter's max frequency F111=50.00Hz, numbers of motor poles F804=4, drive ratio F133=1.00, transmission-shaft radius R=0.05m, then

Transmission shaft perimeter:  $2\pi R = 2 \times 3.14 \times 0.05 = 0.314$  (meter)

Transmission shaft rotary speed:  $60 \times \text{operation frequency} / (\text{numbers of poles pairs} \times \text{drive ratio}) = 60 \times 50 / (2 \times 1.00) = 1500$ rpm

Endmost linear speed: rotary speed  $\times$  perimeter =  $1500 \times 0.314 = 471$  (meters/second)

|      |            |                                                              |                |
|------|------------|--------------------------------------------------------------|----------------|
| F135 | User macro | Setting range:<br>0: Invalid 1: user macro 1 2: user macro 2 | Mfr's value: 0 |
|------|------------|--------------------------------------------------------------|----------------|

When F135=0, user macro parameters are not saved.

When F135=1, all setting parameters are saved in user macro 1.

When F135=2, all setting parameters are saved in user macro 2.

After macro is saved, user can check macro by setting F160=21 or F160=22.

|      |                       |                     |                |
|------|-----------------------|---------------------|----------------|
| F136 | Slip compensation (%) | Setting range: 0~10 | Mfr's value: 0 |
|------|-----------------------|---------------------|----------------|

·Under V/F controlling, rotary speed of motor rotor will decrease as load increases. Be assured that rotor rotate speed is near to synchronization rotary speed while motor with rated load, slip compensation should be adopted according to the setting value of frequency compensation.

Note: during the process of speed track, slip compensation function is invalid. After speed track is finished, this function is valid.

|      |                              |                                                                                                                                                                     |                |
|------|------------------------------|---------------------------------------------------------------------------------------------------------------------------------------------------------------------|----------------|
| F137 | Modes of torque compensation | Setting range:<br>0: Linear compensation;<br>1: Square compensation;<br>2: User-defined multipoint compensation<br>3: Auto torque compensation<br>4: V/F separation | Mfr's value: 0 |
|------|------------------------------|---------------------------------------------------------------------------------------------------------------------------------------------------------------------|----------------|

|                          |                                                                |                                              |
|--------------------------|----------------------------------------------------------------|----------------------------------------------|
| F138 Linear compensation | Setting range: 1~20                                            | Mfr's value:<br>subject to inverter<br>model |
| F139 Square compensation | Setting range: 1: 1.5 2: 1.8<br>3: 1.9 4: 2.0<br>5~6: Reserved | Mfr's value: 1                               |

When F106=2, the function of F137 is valid.

To compensate low-frequency torque controlled by V/F, output voltage of inverter while low-frequency should be compensated.

When F137=0, linear compensation is chosen and it is applied on universal constant-torque load;

When F137=1, square compensation is chose and it is applied on the loads of fan or water pump;

When F137=2, user-defined multipoint compensation is chosen and it is applied on the special loads of spin-drier or centrifuge;

This parameter should be increased when the load is heavier, and this parameter should be decreased when the load is lighter.

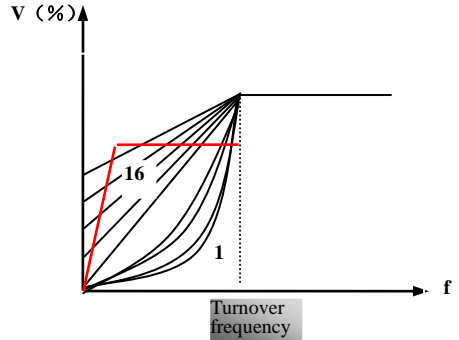

**Fig 6-3 Torque Promotion**

If the torque is elevated too much, motor is easy to overheat, and the current of inverter will be too high. Please check the motor while elevating the torque.

When F137=3, auto torque compensation is chose and it can compensate low-frequency torque automatically, to diminish motor slip, to make rotor rotary speed close to synchro rotary speed and to restrain motor vibration. Customers should set correctly motor power, rotary speed, numbers of motor poles, motor rated current and stator resistance. Please refer to the chapter “Operation process of measuring motor parameters”.

When F137=4, output voltage is not related to output frequency, output frequency is controlled by frequency source, and output voltage is controlled by F671.

|                                                |                          |                    |
|------------------------------------------------|--------------------------|--------------------|
| F140 Voltage compensation point frequency (Hz) | Setting range: 0.00~F142 | Mfr's value: 1.00  |
| F141 Voltage compensation point 1 (%)          | Setting range: 0~30      | Mfr's value: 0     |
| F142 User-defined frequency point F2           | Setting range: F140~F144 | Mfr's value: 5.00  |
| F143 User-defined voltage point V2             | Setting range: 0~100%    | Mfr's value: 13    |
| F144 User-defined frequency point F3           | Setting range: F142~F146 | Mfr's value: 10.00 |
| F145 User-defined voltage point V3             | Setting range: 0~100%    | Mfr's value: 24    |

|      |                                 |                          |                    |
|------|---------------------------------|--------------------------|--------------------|
| F146 | User-defined frequency point F4 | Setting range: F144~F148 | Mfr's value: 20.00 |
| F147 | User-defined voltage point V4   | Setting range: 0~100%    | Mfr's value: 45    |
| F148 | User-defined frequency point F5 | Setting range: F146~F150 | Mfr's value: 30.00 |
| F149 | User-defined voltage point V5   | Setting range: 0~100%    | Mfr's value: 63    |
| F150 | User-defined frequency point F6 | Setting range: F148~F118 | Mfr's value: 40.00 |
| F151 | User-defined voltage point V6   | Setting range: 0~100%    | Mfr's value: 81    |

AS shown in Fig6-3, when F317=0, VF curve compensation =Max (F138, F141)

When F317=1, VF curve compensation =Max (F139, F141)

When F317=2, VF curve compensation =Max (auto compensation, F141)

When F317=3, auto compensation.

F141 cannot be set to high, otherwise, inverter will easily trip into OH and OC.

Multi-stage V/F curves are defined by 12 parameters from F140 to F151.

The setting value of V/F curve is set by motor load characteristic.

Note:  $V1 < V2 < V3 < V4 < V5 < V6$ ,  $F1 < F2 < F3 < F4 < F5 < F6$ . As low-frequency, if the setting voltage is too high, motor will overheat or be damaged. Inverter will be stalling or occur over-current protection.

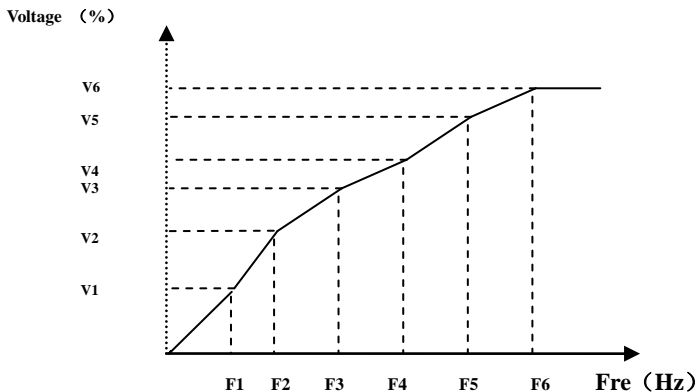

**Fig 6-4 Polygonal-Line Type V/F**

Note: during the process of speed track, polygonal-line V/F curve function is invalid. After speed track is finished, this function is valid.

|                                                         |                       |                  |
|---------------------------------------------------------|-----------------------|------------------|
| F152 Output voltage corresponding to turnover frequency | Setting range: 10~100 | Mfr's value: 100 |
|---------------------------------------------------------|-----------------------|------------------|

This function can meet the needs of some special loads, for example, when the frequency outputs 300Hz

and corresponding voltage outputs 200V (supposed voltage of inverter power supply is 400V), turnover frequency F118 should be set to 300Hz and F152 is set to  $(200 \div 400) \times 100 = 50$ . And F152 should be equal to 50.

Please pay attention to nameplate parameters of motor. If the working voltage is higher than rated voltage or the frequency is higher than rated frequency, motor would be damaged.

Note: during the process of speed track, slip compensation function is invalid. After speed track is finished, this function is valid.

|      |                           |                                 |                               |
|------|---------------------------|---------------------------------|-------------------------------|
| F153 | Carrier frequency setting | Setting range: subject to model | Mfr's value: subject to model |
|------|---------------------------|---------------------------------|-------------------------------|

Carrier-wave frequency of inverter is adjusted by setting this code function. Adjusting carrier-wave may reduce motor noise, avoid point of resonance of mechanical system, decrease leakage current of wire to earth and the interference of inverter.

When carrier-wave frequency is low, although carrier-wave noise from motor will increase, the current leaked to the earth will decrease. The wastage of motor and the temperature of motor will increase, but the temperature of inverter will decrease.

When carrier-wave frequency is high, the situations are opposite, and the interference will raise.

When output frequency of inverter is adjusted to high frequency, the setting value of carrier-wave should be increased. Performance is influenced by adjusting carrier-wave frequency as below table:

|                            |            |
|----------------------------|------------|
| Carrier-wave frequency     | Low → High |
| Motor noise                | Loud → Low |
| Waveform of output current | Bad → Good |
| Motor temperature          | High → Low |
| Inverter temperature       | Low → High |
| Leakage current            | Low → High |
| Interference               | Low → High |

|                                      |                                                                              |                |
|--------------------------------------|------------------------------------------------------------------------------|----------------|
| F154 Automatic voltage rectification | Setting range: 0: Invalid 1: Valid<br>2: Invalid during deceleration process | Mfr's value: 0 |
|--------------------------------------|------------------------------------------------------------------------------|----------------|

This function is enable to keep output voltage constant automatically in the case of fluctuation of input voltage, but the deceleration time will be affected by internal PI adjust. If deceleration time is forbidden being changed, please select F154=2.

|                                                   |                          |                   |
|---------------------------------------------------|--------------------------|-------------------|
| F155 Digital accessory frequency setting          | Setting range: 0.00~F111 | Mfr's value: 0.00 |
| F156 Digital accessory frequency polarity setting | Setting range: 0 ~ 1     | Mfr's value: 0    |
| F157 Reading accessory frequency                  |                          |                   |
| F158 Reading accessory frequency polarity         |                          |                   |

Under combined speed control mode, when accessory frequency source is digital setting memory (F204=0), F155 and F156 are considered as initial set values of accessory frequency and polarity (direction).

In the mode of combined speed control, F157 and F158 are used for reading the value and direction of accessory frequency.

For example, when F203=1, F204=0. F207=1, the given analog frequency is 15Hz, inverter is required to run to 20Hz.

In case of this requirement, user can push “UP” button to raise the frequency from 15Hz to 20Hz. User can also set F155=5Hz and F160=0 (0 means forward, 1 means reverse). In this way, inverter can be run to 20Hz directly.

|                                    |                                    |                |
|------------------------------------|------------------------------------|----------------|
| F159 Random carrier-wave selection | Setting range: 0: Invalid 1: Valid | Mfr’s value: 0 |
|------------------------------------|------------------------------------|----------------|

When F159=0, inverter will modulate as per the carrier-wave set by F153. When F159=1, inverter will operate in mode of random carrier-wave modulating.

Note: when random carrier-wave is selected, output torque will increase but noise will be loud. When the carrier-wave set by F153 is selected, noise will be reduced, but output torque will decrease. Please set the value according to the situation.

|                                       |                                                                                          |                |
|---------------------------------------|------------------------------------------------------------------------------------------|----------------|
| F160 Reverting to manufacturer values | Setting range: 0: Invalid 1: Valid<br>21: revert user macro 1<br>22: revert user macro 2 | Mfr’s value: 0 |
|---------------------------------------|------------------------------------------------------------------------------------------|----------------|

When there is disorder with inverter’s parameters and manufacturer values need to be restored, set F160=1. After “Reverting to manufacturer values” is done, F160 values will be automatically changed to 0.

After setting F135, user can check the parameters of related macro parameters by setting F160. When F160=21, the parameters of macro 1 are reverted. When F160=22, the parameters of macro are reverted.

“Reverting to manufacturer values” will not work for the function-codes marked “o” in the “change” column of the parameters table. These function codes have been adjusted properly before delivery. And it is recommended not to change them.

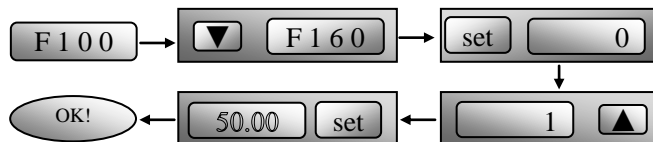

**Figure 6-5 Reverting to manufacturer values**

## 6.2 Operation Control

|                                 |                                                                                                                          |                |
|---------------------------------|--------------------------------------------------------------------------------------------------------------------------|----------------|
| F200<br>Source of start command | Setting range:<br>0: Keypad command;<br>1: Terminal command; 2: Keypad+Terminal;<br>3: MODBUS; 4: Keypad+Terminal+MODBUS | Mfr's value: 4 |
| F201<br>Source of stop command  | Setting range:<br>0: Keypad command;<br>1: Terminal command; 2: Keypad+Terminal;<br>3: MODBUS; 4: Keypad+Terminal+MODBUS | Mfr's value: 4 |

·F200 and F201 are the resource of selecting inverter control commands.

·Inverter control commands include: starting, stopping, forward running, reverse running, jogging, etc.

·"Keypad command" refers to the start/stop commands given by the "Run" or "stop/reset" key on the keypad.

·"Terminal command" refers to the start/stop command given by the "Run" terminal defined by F316-F323.

·When F200=3 and F201=3, the running command is given by MODBUS.

·When F200=2 and F201=2, "keypad command" and "terminal command" are valid at the mean time, F200=4 and F201=4 are the same.

|                                   |                                                                                                                                                                       |                |
|-----------------------------------|-----------------------------------------------------------------------------------------------------------------------------------------------------------------------|----------------|
| F202<br>Mode of direction setting | Setting range:<br>0: Forward running locking;<br>1: Reverse running locking;<br>2: Terminal setting<br>3: Keypad setting<br>4: Keypad setting and direction in memory | Mfr's value: 0 |
|-----------------------------------|-----------------------------------------------------------------------------------------------------------------------------------------------------------------------|----------------|

The running direction is controlled by this function code together with other speed control mode which can set the running direction of inverter. When auto-circulation speed is selected by F500=2, this function code is not valid.

When speed control mode without controlling direction is selected, the running direction of inverter is controlled by this function code, for example, keypad controls speed.

| Direction given by F202 | Direction given by other control mode | Running direction | remarks                              |
|-------------------------|---------------------------------------|-------------------|--------------------------------------|
| 0                       | 0                                     | 0                 | 0 means forward.<br>1 means reverse. |
| 0                       | 1                                     | 1                 |                                      |
| 1                       | 0                                     | 1                 |                                      |
| 1                       | 1                                     | 0                 |                                      |

When F202=3, the running direction can be changed by pressing FWD/REV key. After power off and repower on the inverter, the default running direction is forward.

When F202=4, the running direction can be changed by pressing FWD/REV key. The setting direction by keypad is in memory.

|                                         |                                                                                                                                                                                                                                                                                               |                       |
|-----------------------------------------|-----------------------------------------------------------------------------------------------------------------------------------------------------------------------------------------------------------------------------------------------------------------------------------------------|-----------------------|
| <p>F203<br/>Main frequency source X</p> | <p>Setting range:<br/>0: Memory of digital given;<br/>1: External analog AI1;<br/>2: External analog AI2;<br/>3: Pulse input given;<br/>4: Stage speed control;<br/>5: No memory of digital given;<br/>6: Keypad potentiometer; 7: Reserved;<br/>8:Reserved; 9: PID adjusting; 10: MODBUS</p> | <p>Mfr's value: 0</p> |
|-----------------------------------------|-----------------------------------------------------------------------------------------------------------------------------------------------------------------------------------------------------------------------------------------------------------------------------------------------|-----------------------|

·Main frequency source is set by this function code.

#### 0: Memory of digital given

Its initial value is the value of F113. The frequency can be adjusted through the key “up” or “down”, or through the “up”, “down” terminals.

“Memory of digital given” means after inverter stops, the target frequency is the running frequency before stop. If the user would like to save target frequency in memory when the power is disconnected, please set F220=1, i.e. frequency memory after power down is valid.

#### 1: External analog AI1; 2: External analog AI2

The frequency is set by analog input terminal AI1 and AI2. The analog signal may be current signal (0-20mA or 4-20mA) or voltage signal (0-5V or 0-10V), which can be chosen by switch code. Please adjust the switch code according to practical situations, refer to fig 5-4 and table 5-2.

When inverters leave the factory, the analog signal of AI1 channel is DC voltage signal, the range of voltage is 0-10V, and the analog signal of AI2 channel is DC current signal, the range of current is 0-20 mA. If 4-20mA current signal is needed, please set lower limit of analog input F406=2, which input resistor is 500OHM. If some errors exist, please make some adjustments.

#### 3: Pulse input given

When frequency is given by pulse input, the pulse is only inputted by DI1 terminal. The max pulse frequency is 10K. The related parameters are from F440 to F446.

#### 4: Stage speed control

Multi-stage speed control is selected by setting stage speed terminals F316-F323 and function codes of multi-stage speed section. The frequency is set by multi-stage terminal or automatic cycling frequency.

#### 5: No memory of digital given

Its initial value is the value of F113. The frequency can be adjusted through the key “up” or “down”, or through the “up”, “down” terminals.

“No memory of digital given” means that the target frequency will restore to the value of F113 after stop no matter the state of F220.

#### 6: Keypad Potentiometer AI3

The frequency is set by the analog on the control panel. When the potentiometer in remote keypad is used, please set F422=1.

#### 9: PID adjusting

When PID adjusting is selected, the running frequency of inverter is the value of frequency adjusted by PID. Please refer to instructions of PID parameters for PID given resource, PID given numbers, feedback source, and so on.

10: MODBUS

The main frequency is given by MODBUS communication.

|                                     |                                                                                                                                                                                                    |                |
|-------------------------------------|----------------------------------------------------------------------------------------------------------------------------------------------------------------------------------------------------|----------------|
| F204 Accessorial frequency source Y | Setting range:<br>0: Memory of digital given; 1: External analog AI1;<br>2: External analog AI2; 3: Pulse input given;<br>4: Stage speed control; 5: PID adjusting;<br>6: Keypad potentiometer AI3 | Mfr's value: 0 |
|-------------------------------------|----------------------------------------------------------------------------------------------------------------------------------------------------------------------------------------------------|----------------|

- When accessorial frequency Y is given to channel as independent frequency, it has the same function with main frequency source X.
- When F204=0, the initial value of accessorial frequency is set by F155. When accessorial frequency controls speed independently, polarity setting F156 is not valid.
- When F207=1 or 3, and F204=0, the initial value of accessorial frequency is set by F155, the polarity of accessorial frequency is set by F156, the initial value of accessorial frequency and the polarity of accessorial frequency can be checked by F157 and F158.
- When the accessorial frequency is given by analog input (AI1, AI2), the setting range for the accessorial frequency is set by F205 and F206.
- Note: accessorial frequency source Y and main frequency source X can not use the same frequency given channel.

|                                                                   |                                                                                    |                  |
|-------------------------------------------------------------------|------------------------------------------------------------------------------------|------------------|
| F205 reference for selecting accessorial frequency source Y range | Setting range:<br>0: Relative to max frequency;<br>1: Relative to main frequency X | Mfr's value: 0   |
| F206 Accessorial frequency Y range (%)                            | Setting range: 0~150                                                               | Mfr's value: 100 |

·When combined speed control is adopted for frequency source, F206 is used to confirm the relative object of the setting range for the accessorial frequency.

F205 is to confirm the reference of the accessorial frequency range. If it is relative to main frequency, the range will change according to the change of main frequency X.

|                                 |                                                                                                                                                                                                                                             |                |
|---------------------------------|---------------------------------------------------------------------------------------------------------------------------------------------------------------------------------------------------------------------------------------------|----------------|
| F207 Frequency source selecting | Setting range:<br>0: X; 1: X+Y;<br>2: X or Y (terminal switchover);<br>3: X or X+Y (terminal switchover);<br>4: Combination of stage speed and analog<br>5: X-Y 6: X+Y-Y <sub>MAX</sub> *50%<br>7: combination 1 of stage speed and digital | Mfr's value: 0 |
|---------------------------------|---------------------------------------------------------------------------------------------------------------------------------------------------------------------------------------------------------------------------------------------|----------------|

Select the channel of setting the frequency. The frequency is given by combination of main frequency X and accessorial frequency Y.

When F207=0, the frequency is set by main frequency source.

When F207=1, X+Y, the frequency is set by adding main frequency source to accessorial frequency



source. X or Y can be given by PID.

When F207=2, main frequency source and accessorial frequency source can be switched over by frequency source switching terminal.

When F207=3, main frequency given and adding frequency given(X+Y) can be switched over by frequency source switching terminal. X or Y can be given by PID.

When F207=4, stage speed setting of main frequency source has priority over analog setting of accessorial frequency source (only suitable for F203=4 F204=1).

When F207=5, X-Y, the frequency is set by subtracting accessorial frequency source from main frequency source. If the frequency is set by main frequency or accessorial frequency, PID speed control can be selected.

When F207=6,  $X+Y-Y_{MAX} * 50\%$ , the frequency is given by both main frequency source and accessorial frequency source. X or Y can be given by PID. When F205=0,  $Y_{MAX}=F111 * F206$ . When F205=1,  $Y_{MAX}=X * F206$ .

When F207=7, stage speed setting of main frequency source has priority over digital of accessorial frequency source. (only suitable for F203=4, F204=0).

**Note:**

- When F203=4 and F204=1, the difference between F207=1 and F207=4 is that when F207=1, frequency source selecting is the addition of stage speed and analog, when F207=4, frequency source selecting is stage speed with stage speed and analog given at the same time. If stage speed given is canceled and analog given still exists, inverter will run by analog given.
- Frequency given mode can be switched over by selecting F207. For example: switching PID adjusting and normal speed control, switching stage speed and analog given, switching PID adjusting and analog given, and so on.
- The acceleration/deceleration time of stage speed is set by function code of corresponding stage speed time. When combined speed control is adopted for frequency source, the acceleration/deceleration time is set by F114 and F115.
- The mode of automatic cycle speed control is unable to combine with other modes.
- When F207=2 (main frequency source and accessorial frequency source can be switched over by terminals), if main frequency is not set to be under stage-speed control, accessorial frequency can be set to be under automatic cycle speed control (F204=5, F500=0). Through the defined switchover terminal, the control mode (defined by X) and automatic cycle speed control (defined by Y) can be freely switched.
- When F207=6, F205=0 and F206=100,  $X+Y-Y_{MAX} * 50\% = X+Y-F111 * 50\%$ , and if F207=6, F205=1 and F206=100, then  $X+Y-Y_{MAX} * 50\% = X+Y-X * 50\%$ .

|                                                                        |                                                                                                                                                                                                                                      |                       |
|------------------------------------------------------------------------|--------------------------------------------------------------------------------------------------------------------------------------------------------------------------------------------------------------------------------------|-----------------------|
| <p>F208<br/>Terminal<br/>two-line/three-line<br/>operation control</p> | <p>Setting range:<br/>0: No function<br/>1: Two-line operation mode 1;<br/>2: Two-line operation mode 2;<br/>3: three-line operation mode 1;<br/>4: three-line operation mode 2;<br/>5: start/stop controlled by direction pulse</p> | <p>Mfr's value: 0</p> |
|------------------------------------------------------------------------|--------------------------------------------------------------------------------------------------------------------------------------------------------------------------------------------------------------------------------------|-----------------------|

·When selecting two-line type or three-line type, F200, F201 and F202 are invalid.

**Five modes are available for terminal operation control.**

**Note:** “FWD”, “REV” and “X” are three terminals designated in programming DI1~DI8.

1: Two-line mode 1: this mode is the most popularly used two-line mode. The running direction of mode is controlled by FWD, REV terminals.

**For example: “FWD” terminal-----“open”: stop, “closed”: forward running;**

**“REV” terminal-----“open”: stop, “closed”: reverse running;**

**“CM” terminal-----common port**

| K1 | K2 | Running command |
|----|----|-----------------|
| 0  | 0  | Stop            |
| 1  | 0  | Forward running |
| 0  | 1  | Reverse running |
| 1  | 1  | Stop            |

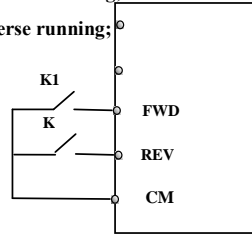

2. Two-line mode 2: when this mode is used, FWD is enable terminal, the direction is controlled by REV terminal.

**For example: “FWD” terminal-----“open”: stop, “closed”: running;**

**“REV” terminal-----“open”: forward running,**

**“closed”: reverse running;**

**“CM” terminal-----common port**

| K1 | K2 | Running command |
|----|----|-----------------|
| 0  | 0  | Stop            |
| 0  | 1  | Stop            |
| 1  | 0  | Forward running |
| 1  | 1  | Reverse running |

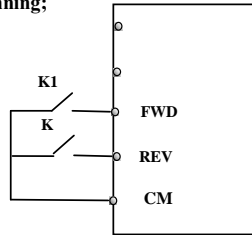

3. Three-line mode 1:

In this mode, X terminal is enable terminal, the direction is controlled by FWD terminal and REV terminal. Pulse signal is valid.

Stopping commands is enabled by opening X terminal.

**SB3: Stop button**

**SB2: Forward button.**

**SB1: Reverse button.**

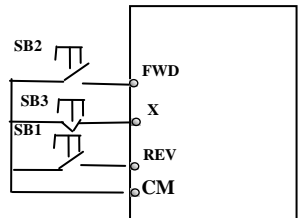

## 4. Three-line mode 2:

In this mode, X terminal is enable terminal, running command is controlled by FWD terminal. The running direction is controlled by REV terminal, and stopping command enable by opening X terminal.

**SB1: Running button**

**SB2: Stop button**

**K1: direction switch. Open stands for forward running; close stands for reverse running.**

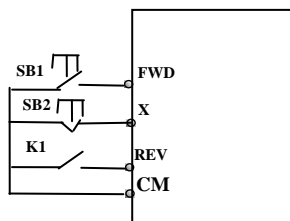

## 5. Start/stop controlled by direction pulse:

“FWD” terminal—(impulse signal: forward/stop)

“REV” terminal—(impulse signal: reverse/stop)

“CM” terminal—common port

Note: when pulse of SB1 triggers, inverter will run forward. When the pulse triggers again, inverter will stop running.

When pulse of SB2 triggers, inverter will run reverse. When the pulse triggers again, inverter will stop running.

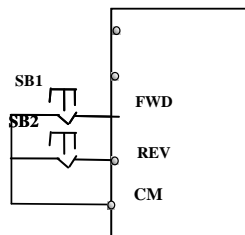

|      |                                          |                                                                                       |                |
|------|------------------------------------------|---------------------------------------------------------------------------------------|----------------|
| F209 | Selecting the mode of stopping the motor | Setting range:<br>0: stop by deceleration time; 1: free stop<br>2: Stop by DC braking | Mfr's value: 0 |
|------|------------------------------------------|---------------------------------------------------------------------------------------|----------------|

When the stop signal is input, stopping mode is set by this function code:

F209=0: stop by deceleration time

Inverter will decrease output frequency according to setting acceleration/deceleration curve and decelerating time, after frequency decreases to 0, inverter will stop. This is often common stopping type. During the process of speed track, this function is invalid. And inverter will be forced to stop during this process.

F209=1: free stop

After stop command is valid, inverter will stop output. Motor will free stop by mechanical inertia.

When F209=2, after inverter receives stop command, inverter will stop from present frequency by DC braking. Please set F656, F603 and F605 correctly to avoid error.

|      |                            |                          |                   |
|------|----------------------------|--------------------------|-------------------|
| F210 | Frequency display accuracy | Setting range: 0.01~2.00 | Mfr's value: 0.01 |
|------|----------------------------|--------------------------|-------------------|

When inverter is in the running status, under keypad speed control, frequency display accuracy is set by F210 and the range is from 0.01 to 2.00. For example, when F210=0.5, ▲/▼ terminal is pressed at one time, frequency will increase or decrease by 0.5Hz.

This function is valid when inverter is in the running state.

|      |                                 |                           |                   |
|------|---------------------------------|---------------------------|-------------------|
| F211 | Speed of digital control (Hz/S) | Setting range: 0.01~100.0 | Mfr's value: 5.00 |
|------|---------------------------------|---------------------------|-------------------|

When UP/DOWN terminal is pressed, frequency will change at the setting rate. The Mfr's value is

5.00Hz/s.

|                       |                                    |                |
|-----------------------|------------------------------------|----------------|
| F212 Direction memory | Setting range: 0: Invalid 1: Valid | Mfr's value: 0 |
|-----------------------|------------------------------------|----------------|

· This function is valid when three-line operation mode 1(F208=3) is valid.

· When F212=0, after inverter is stopped, resetted and repowered on, the running direction is not memorized.

· When F212=1, after inverter is stopped, resetted and repowered on, if inverter starts running but no direction signal, inverter will run according the memory direction.

|                                       |                                     |                |
|---------------------------------------|-------------------------------------|----------------|
| F213 Auto-starting after repowered on | Setting range: 0: invalid; 1: valid | Mfr's value: 0 |
| F214 Auto-starting after reset        | Setting range: 0: invalid; 1: valid | Mfr's value: 0 |

Whether or not to start automatically after repowered on is set by F213

F213=1, Auto-starting after repowered on is valid. When inverter is power off and then powered on again, it will run automatically after the time set by F215 and according to the running mode before power-down.

If F220=0 frequency memory after power-down is not valid, inverter will run by the setting value of F113. F213=0, after repower-on, inverter will not run automatically unless running command is given to inverter.

Whether or not to start automatically after fault resetting is set by F214

When F214=1, if fault occurs, inverter will reset automatically after delay time for fault reset (F217). After resetting, inverter will run automatically after the auto-starting delay time (F215).

If frequency memory after power-down (F220) is valid, inverter will run at the speed before power-down. Otherwise, inverter will run at the speed set by F113.

In case of fault under running status, inverter will reset automatically and auto-start. In case of fault under stopped status, the inverter will only reset automatically.

When F214=0, after fault occurs, inverter will display fault code, it must be reset by manually.

|                               |                           |                   |
|-------------------------------|---------------------------|-------------------|
| F215 Auto-starting delay time | Setting range: 0.1~3000.0 | Mfr's value: 60.0 |
|-------------------------------|---------------------------|-------------------|

F215 is the auto-starting delay time for F213 and F214. The range is from 0.1s to 3000.0s.

|                                                        |                                                           |                  |
|--------------------------------------------------------|-----------------------------------------------------------|------------------|
| F216 Times of auto-starting in case of repeated faults | Setting range: 0~5                                        | Mfr's value: 0   |
| F217 Delay time for fault reset                        | Setting range: 0.0~10.0                                   | Mfr's value: 3.0 |
| F219 EEPROM write operation                            | Setting range: 0: enabled to write<br>1: prohibit writing | Mfr's value: 1   |

F216 sets the most times of auto-starting in case of repeated faults. If starting times are more than the setting value of this function code, inverter will not reset or start automatically after fault. Inverter will run after running command is given to inverter manually.

F217 sets delay time for fault reset. The range is from 0.0 to 10.0S which is time interval from fault to resetting.

When F219=1 (address 2001H is not operated by PC/PLC), the function code is modified by communication, and it is not saved in the EEPROM. It means there is no memory when power down.

When F219=0 ((address 2001H is not operated by PC/PLC), the function code is modified by communication, and it is saved in the EEPROM. It means there is memory when power down.

|                                        |                                     |                |
|----------------------------------------|-------------------------------------|----------------|
| F220 Frequency memory after power-down | Setting range: 0: invalid; 1: valid | Mfr's value: 0 |
|----------------------------------------|-------------------------------------|----------------|

F220 sets whether or not frequency memory after power-down is valid.

This function is valid for F213 and F214. Whether or not to memory running state after power-down or malfunction is set by this function.

The function of frequency memory after power-down is valid for main frequency and accessorial frequency that is given by digital. Because the digital given accessorial frequency has positive polarity and negative polarity, it is saved in the function codes F155 and F156.

|                             |                                    |                 |
|-----------------------------|------------------------------------|-----------------|
| F221 X+Y-50% (%)            | Setting range: 0~200               | Mfr's value: 50 |
| F222 count memory selection | Setting range: 0: Invalid 1: Valid | Mfr's value: 0  |

F220 sets whether or not count memory is valid. Whether or not to memory counting values after power-down or malfunction is set by this function.

|                                 |                          |                    |
|---------------------------------|--------------------------|--------------------|
| F223 Main frequency coefficient | Setting range: 0.0~100.0 | Mfr's value: 100.0 |
|---------------------------------|--------------------------|--------------------|

Target frequency=main frequency\*main frequency coefficient.

|                                                        |                                                   |                |
|--------------------------------------------------------|---------------------------------------------------|----------------|
| F224 when target frequency is lower than Min frequency | Setting range:<br>0: stop 1: run at min frequency | Mfr's value: 0 |
|--------------------------------------------------------|---------------------------------------------------|----------------|

·F224=0, when target frequency is lower than Min frequency, inverter will stop.

·F224=1, when target frequency is lower than Min frequency, inverter will run at Min frequency.

**Table 6-1 Combination of Speed Control**

| F203 \ F204                    | 0. Memory of digital setting | 1 External analog AI1 | 2 External analog AI2 | 3 Pulse input given | 4 Terminal stage speed control | 5 PID adjusting | 6 Analog AI3 |
|--------------------------------|------------------------------|-----------------------|-----------------------|---------------------|--------------------------------|-----------------|--------------|
| 0 Memory of Digital setting    | ○                            | ●                     | ●                     | ●                   | ●                              | ●               | ●            |
| 1 External analog AI1          | ●                            | ○                     | ●                     | ●                   | ●                              | ●               | ●            |
| 2 External analog AI2          | ●                            | ●                     | ○                     | ●                   | ●                              | ●               | ●            |
| 3 Pulse input given            | ●                            | ●                     | ●                     | ○                   | ●                              | ●               | ●            |
| 4 Terminal Stage speed control | ●                            | ●                     | ●                     | ●                   | ○                              | ●               | ●            |
| 5 Digital setting              | ○                            | ●                     | ●                     | ●                   | ●                              | ●               | ●            |
| 6 Analog AI3                   | ●                            | ●                     | ●                     | ●                   | ●                              | ●               | ○            |
| 9 PID adjusting                | ●                            | ●                     | ●                     | ●                   | ●                              | ○               | ●            |
| 10 MODBUS                      | ●                            | ●                     | ●                     | ●                   | ●                              | ●               | ●            |

●: Inter-combination is allowable.

○: Combination is not allowable.

The mode of automatic cycle speed control is unable to combine with other modes. If the combination

includes the mode of automatic cycle speed control, only main speed control mode will be valid.

|                                                            |                                           |                   |
|------------------------------------------------------------|-------------------------------------------|-------------------|
| F234 switchover frequency during deceleration process (Hz) | Setting range:<br>0.00: invalid 0.00~F111 | Mfr's value: 0.00 |
|------------------------------------------------------------|-------------------------------------------|-------------------|

· In stage-speed mode, during deceleration process, if the running frequency is higher than F234, inverter will run at the second deceleration time.

Note: this function code is only for special function of washing machine.

### Traverse Operating function

Traverse operation is widely used in textile and chemical fiber industry.

|      |                         |                                                                                                            |                |
|------|-------------------------|------------------------------------------------------------------------------------------------------------|----------------|
| F235 | Traverse operating mode | 0: Invalid<br>1: Traverse operating mode 1<br>2: Traverse operating mode 2<br>3: Traverse operating mode 3 | Mfr's value: 0 |
|------|-------------------------|------------------------------------------------------------------------------------------------------------|----------------|

F235=0, this function is invalid.

F235=1, traverse operating mode 1, the central frequency is set by F242, and the working process is shown in Fig 6-6.

F235=2, traverse operating mode 2, the central frequency is on the decrease, the working process is shown in Fig 6-7.

F235=3, traverse operating mode 3, the central frequency is set by F203. Under this mode, if the central frequency set by F203 is lower than the lower limit of central frequency, inverter will not stop running. In the other traverse operating mode, the value of central frequency is controlled by F243.

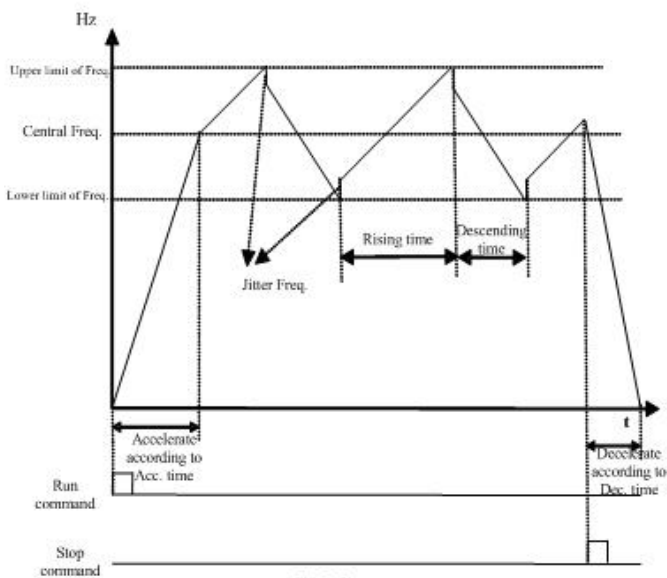

Fig 6-6

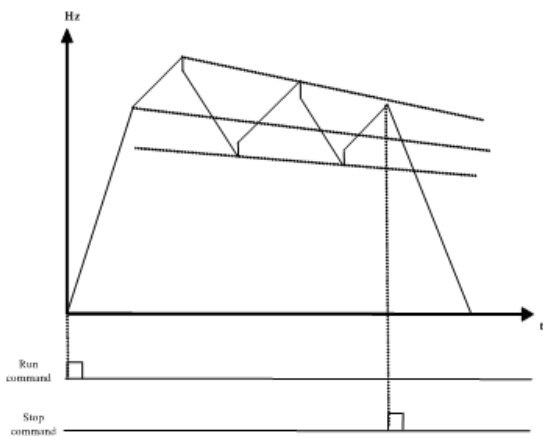

Fig 6-7

|      |                   |                        |                |
|------|-------------------|------------------------|----------------|
| F236 | Crawl-positioning | 0: Disabled 1: Enabled | Mfr's value: 0 |
|------|-------------------|------------------------|----------------|

Crawl-positioning mode: when this mode is enabled, if inverter gets the signal of stop, full of yarn, broken of yarn, fixed length control, inverter will run to the frequency of crawl-positioning (F252). After the waiting time of crawl-positioning (F253), if inverter gets a positioning stop signal, inverter will stop (the positioning stop signal is invalid within crawl-positioning waiting time). If there is no positioning stop signal, inverter will stop automatically after max time of crawl-positioning time (F524). Note: if F524=0, inverter will not stop automatically.

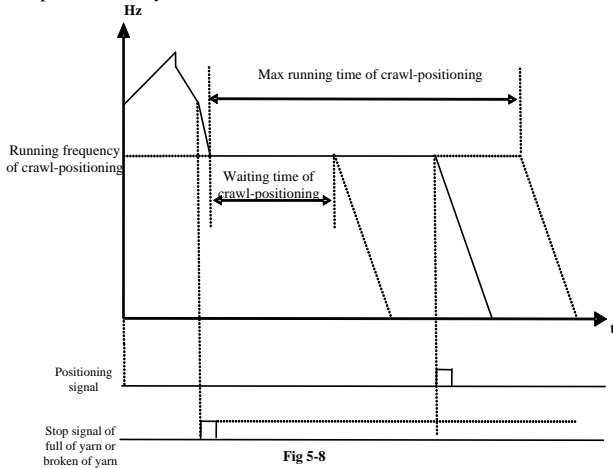

Fig 5-8

|      |                        |                                   |                |
|------|------------------------|-----------------------------------|----------------|
| F237 | Traverse signal source | 0: Auto start 1: X terminal start | Mfr's value: 0 |
|------|------------------------|-----------------------------------|----------------|

·When F237=0 and F235≠0, inverter will run by traverse mode.

·When F237=1 and F235≠0, user should set DIX terminal as traverse start terminal, when this terminal is valid, traverse function is valid.

|      |                             |                                                                                                                                                                                                  |                |
|------|-----------------------------|--------------------------------------------------------------------------------------------------------------------------------------------------------------------------------------------------|----------------|
| F238 | Stop mode of length arrival | 0: Stop the motor at fixed length<br>1: Stop the motor at fixed spindle radius<br>2: Non-stop at fixed length, it indicates full of yarn.<br>3: Fixed radius arrival, it indicates full of yarn. | Mfr's value: 0 |
| F239 | Traverse memory mode        | 0: Memory at the status of stop and power off<br>1: Only memory at the status of stop.<br>2: Only memory at the status of power off.<br>3: No memory.                                            | Mfr's value: 0 |

F238=0 or 1, when fixed length or fixed radius is arrival, inverter will stop.

F238=2 or 3, when fixed length or fixed radius is arrival, multifunction terminals (DO1, DO2 and relay output terminal) will output signal. Inverter will not stop, and "ovEr" will be displayed in the panel.

|      |                                      |           |                   |
|------|--------------------------------------|-----------|-------------------|
| F240 | Preset frequency (Hz)                | F112~F111 | Mfr's value: 5.00 |
| F241 | Running time of preset frequency (S) | 0~3000    | Mfr's value: 0    |

F240 is used to define the inverter's operating frequency before entering traverse mode.



F241 is used to define the time when the inverter operates at pre-traverse frequency.

|      |                                               |                                                                  |                    |
|------|-----------------------------------------------|------------------------------------------------------------------|--------------------|
| F242 | Central frequency (Hz)                        | F243~F111                                                        | Mfr's value: 25.00 |
| F243 | Lower limit of central frequency (Hz)         | F112~F242                                                        | Mfr's value: 0.50  |
| F244 | Descending rate of central frequency (Hz / S) | 0.100~65.000                                                     | Mfr's value: 0.500 |
| F247 | Traverse amplitude setting mode               | 0: Relative to max frequency<br>1: Relative to central frequency | Mfr's value: 1     |
| F248 | Traverse amplitude (%)                        | 0.00~100.00                                                      | Mfr's value: 10.0  |
| F249 | Jump frequency (%)                            | 0.00~50.00                                                       | Mfr's value: 30.00 |
| F250 | Rising time of traverse (S)                   | 0.1~3000                                                         | Mfr's value: 10.0  |
| F251 | Descending time of traverse (S)               | 0.1~3000                                                         | Mfr's value: 10.0  |
| F252 | Crawl-positioning frequency (Hz)              | F112~F111                                                        | Mfr's value: 3.00  |
| F253 | Waiting time of crawl-positioning (S)         | 0.0~3000                                                         | Mfr's value: 5.0   |
| F254 | Max time of crawl-positioning (S)             | 0.0~3000                                                         | Mfr's value: 10.0  |

Please refer to Fig 6-6, 6-7 and 6-8.

If the lower limit frequency of traverse amplitude is lower than min frequency F112, then the lower limit of frequency of traverse amplitude turns to min frequency of inverter. If the upper limit frequency of traverse amplitude is higher than the max frequency F111, the frequency of traverse amplitude will turn to max frequency of inverter.

Jitter frequency is the percent of traverse amplitude, which is set by F249.

|      |                                |            |                   |
|------|--------------------------------|------------|-------------------|
| F257 | Cumulative length (Km)         | 0.00~6500  | Mfr's value: 0.00 |
| F258 | Actual length (Km)             | 0.00~65.00 | Mfr's value: 0.00 |
| F259 | Setting length (Km)            | 0.00~65.00 | Mfr's value: 0.00 |
| F260 | Pulse numbers of length sensor | 0.01~650.0 | Mfr's value: 1.00 |

In fixed length control mode, the function of F257~F260 is valid.

|      |                          |                                                                                             |                |
|------|--------------------------|---------------------------------------------------------------------------------------------|----------------|
| F262 | Clear yarn broken signal | Setting range:<br>0: stop and refer to yarn broken signal<br>1: refer to yarn broken signal | Mfr's value: 0 |
|------|--------------------------|---------------------------------------------------------------------------------------------|----------------|

When F262=0, after inverter stops, if there is no yarn broken signal, then clear yarn broken malfunction.

When F262=1, if there is no yarn broken signal, then clear yarn broken malfunction.

|      |                                                               |               |                   |
|------|---------------------------------------------------------------|---------------|-------------------|
| F264 | Feedback channel of fixed radius                              | 0: AI1 1: AI2 | Mfr's value: 0    |
| F265 | Fixed-radius display value                                    | 0~10000       | Mfr's value: 1000 |
| F266 | Output voltage at fixed radius mode (V)                       | 0.00~10.00    | Mfr's value: 5.00 |
| F267 | Voltage hysteresis when judging full of yarn signal is clear. | 0.00~10.00    | Mfr's value: 0.00 |

F265 is used to set the display value corresponding to analog max value.

F266 is used to set output voltage of fixed radius sensor when fixed radius is arrival.

·Voltage hysteresis is set by F267. For example: if F266=5.00, F267=0.30, only when the feedback voltage is lower than 4.70V, inverter will judge full of yarn signal clear.

|      |                                     |           |                        |
|------|-------------------------------------|-----------|------------------------|
| F269 | DI pre-alarm current                | Read only | Mfr's value: read only |
| F270 | DI pre-alarm current threshold (A)  | 0.01~6.00 | Mfr's value: 0.50      |
| F271 | DI pre-alarm current delay time (S) | 5~60      | Mfr's value: 30        |

When the function of DI pre-alarm is valid, running current will be saved in F269, Which is pre-alarm current value and not be changed. If DI terminal is enabled again, and running current is higher than (DI pre-alarm current + DI pre-alarm current threshold), after delay time of F271, DO terminal will output pre-alarm signal, but inverter will not stop. When running current is lower than (DI pre-alarm current + DI pre-alarm current threshold), DO terminal will not output pre-alarm signal.

Note: when DI terminal is invalid or not in running state, this function is invalid.

|      |                                                     |          |     |
|------|-----------------------------------------------------|----------|-----|
| F272 | Delay time of broken yarn and intertwining yarn (S) | 0.0~3000 | 0.0 |
|------|-----------------------------------------------------|----------|-----|

The delay time after judging broken of yarn and intertwining yarn.

when broken of yarn, BRK1 is displayed. When full of yarn, BRK2 is displayed.

|      |                              |            |                           |
|------|------------------------------|------------|---------------------------|
| F275 | Detect frequency value (Hz)  | F112~F111  | 25.00                     |
| F276 | Detect frequency width (Hz)  | 0.00~20.00 | 0.50                      |
| F277 | Third Acceleration Time (S)  | 0.1-3000   | Subject to inverter model |
| F278 | Third Deceleration Time (S)  |            |                           |
| F279 | Fourth Acceleration Time (S) |            |                           |
| F280 | Fourth Deceleration Time (S) |            |                           |

When inverter runs to diction frequency set by F275, the multifunction terminal will output a signal.

## 6.3. Multifunctional Input and Output Terminals

### 6.3.1 Digital multifunctional output terminals

|      |                    |                                                                          |                 |
|------|--------------------|--------------------------------------------------------------------------|-----------------|
| F300 | Relay token output | Setting range: 0~59<br><br>Refer to table 6-2 for detailed instructions. | Mfr's value: 1  |
| F301 | DO1 token output   |                                                                          | Mfr's value: 14 |
| F302 | DO2 token output   |                                                                          | Mfr's value: 5  |

E2000 inverter has one multifunctional relay output terminal. Inverters of 30kW and below 30 kW have one multifunctional digital output terminals (without DO2 terminal), inverters above 30 kW have two multifunctional digital output terminals.

In water supply system, if the fixed mode or timing interchanging mode is selected, relay token output and DO1 token output is invalid.

**Table 6-2 Instructions for digital multifunctional output terminal**

| Value | Function                                  | Instructions                                                                                                                                                                                                                        |
|-------|-------------------------------------------|-------------------------------------------------------------------------------------------------------------------------------------------------------------------------------------------------------------------------------------|
| 0     | no function                               | Output terminal has no functions.                                                                                                                                                                                                   |
| 1     | inverter fault protection                 | When inverter works wrong, ON signal is output.                                                                                                                                                                                     |
| 2     | over latent frequency 1                   | Please refer to instructions from F307 to F309.                                                                                                                                                                                     |
| 3     | over latent frequency 2                   | Please refer to instructions from F307 to F309.                                                                                                                                                                                     |
| 4     | free stop                                 | Under free stop status, after stop command is given, ON signal is output until inverter completely stops.                                                                                                                           |
| 5     | In running status 1                       | Indicating that inverter is running and ON signal is output.                                                                                                                                                                        |
| 6     | Reserved                                  | Reserved                                                                                                                                                                                                                            |
| 7     | acceleration/deceleration time switchover | Indicating that inverter is in the status of acceleration/deceleration time switchover                                                                                                                                              |
| 8     | Reaching the Set Count Value              | This terminal will be "action" when inverter carries the external count instruction and count value reaches the set value of F314.                                                                                                  |
| 9     | Reaching the Designated Count Value       | This terminal will be "action" when inverter carries the external count instruction and count value reaches the set value of F315.                                                                                                  |
| 10    | inverter overload pre-alarm               | When inverter is in over current status, if the accumulation time is more than inverter's overload protection time * F704, inverter outputs ON signal. After over current disappears or OL1 is enable, the signal output will stop. |
| 11    | motor overload pre-alarm                  | When motor is in over current status, if the accumulation time is more than motor's overload protection time * F705, inverter outputs ON signal. After over current disappears or OL2 is enable, the signal output will stop.       |
| 12    | stalling                                  | During accel/decel process, inverter stops accelerating/decelerating because inverter is stalling, and ON signal is output.                                                                                                         |
| 13    | Inverter is ready to run                  | When inverter is powered on. Protection function is not in action and inverter is ready to run, then ON signal is output.                                                                                                           |
| 14    | In running status 2                       | Indicating that inverter is running and ON signal is output. When inverter is running at 0HZ, it seems as the running status, and ON signal is output.                                                                              |
| 15    | frequency arrival output                  | Indicating inverter runs to the setting target frequency, and ON signal is output. See F312.                                                                                                                                        |

|    |                                                                                      |                                                                                                                                                                                                                                                                                            |
|----|--------------------------------------------------------------------------------------|--------------------------------------------------------------------------------------------------------------------------------------------------------------------------------------------------------------------------------------------------------------------------------------------|
| 16 | overheat pre-alarm                                                                   | When testing temperature reaches 80% of setting value, ON signal is output. When overheat protection occurs or testing value is lower than 80% of setting value, ON signal stops outputting.                                                                                               |
| 17 | over latent current output                                                           | When output current of inverter reaches the setting overlatent current, ON signal is output. See F310 and F311.                                                                                                                                                                            |
| 18 | Analog line disconnection protection                                                 | Indicating inverter detects analog input lines disconnection, and ON signal is output. Please refer to F741.                                                                                                                                                                               |
| 19 | Under-load 1 pre-alarm                                                               | Please refer to FA26 and FA27.                                                                                                                                                                                                                                                             |
| 20 | Zero current detecting output                                                        | When inverter output current has fallen to zero current detecting value, and after the setting time of F755, ON signal is output. Please refer to F754 and F755.                                                                                                                           |
| 21 | Output controlled by communication address 2005H                                     | 1 means output is valid.<br>0 means output is invalid.                                                                                                                                                                                                                                     |
| 22 | Output controlled by communication address 2006H                                     |                                                                                                                                                                                                                                                                                            |
| 23 | Output controlled by communication address 2007H                                     |                                                                                                                                                                                                                                                                                            |
| 24 | Watchdog output token                                                                | Output signal is valid when inverter trips into Err6.                                                                                                                                                                                                                                      |
| 25 | DI Pre-alarm current                                                                 | Indicating pre-alarm states of running current higher than pre-alarm current (F269+F270)                                                                                                                                                                                                   |
| 26 | Communication reset                                                                  | When faults occur, inverter will be reset by Modbus writing 9 to 0x2000.                                                                                                                                                                                                                   |
| 30 | General pump is running                                                              | Indicating some general pumps are running.                                                                                                                                                                                                                                                 |
| 31 | Converter pump is running                                                            | Indicating some converter pumps are running.                                                                                                                                                                                                                                               |
| 32 | Over-limit pressure token                                                            | Indicating the max limit value when PID adjusting is valid and negative feedback is selected, and feedback pressure is higher than max pressure set by F503                                                                                                                                |
| 35 | Stop signal of yarn full, yarn broken, yarn intertwining and stop inverter by manual | Indicating stop signal of yarn full, yarn broken, yarn intertwining and stop inverter by manual                                                                                                                                                                                            |
| 36 | Full yarn signal                                                                     | Indicating yarn is full.                                                                                                                                                                                                                                                                   |
| 37 | Output signal of traverse rising                                                     | Indicating traverse is rising.                                                                                                                                                                                                                                                             |
| 38 | Traverse wave form output                                                            | Indicating inverter is in the traverse status.                                                                                                                                                                                                                                             |
| 39 | Yarn frequency detected                                                              | This function is valid when it is higher than yarn frequency, or else it is invalid.                                                                                                                                                                                                       |
| 42 | The second motor token output                                                        | Indicating the current motor is the second motor.                                                                                                                                                                                                                                          |
| 43 | Communication timeout 2                                                              | When F907>0, and receiving the previous data, if after the time set by F907, the next data is not received, inverter will output communication timeout signal. The timeout signal will be cleared by this terminal, and after receiving correct data, inverter will accumulate time again. |
| 45 | Token output when lower than setting temperature                                     | When temperature is lower or equal to 0°C, token output signal is valid. When temperature is higher than 0°C+2°C, token output is invalid.                                                                                                                                                 |
| 59 | oPEn                                                                                 | When drive trips into oPEn, the terminal is valid.                                                                                                                                                                                                                                         |

|                                |                                                 |                |
|--------------------------------|-------------------------------------------------|----------------|
| F303 DO output types selection | Setting range: 0: level output 1 : pulse output | Mfr's value: 0 |
|--------------------------------|-------------------------------------------------|----------------|

·When level output is selected, all terminal functions in table 6-2 can be defined by F301.

·When pulse output is selected, DO1 can be defined as high-speed pulse output terminal. The max pulse frequency is 100KHz. The related function codes are F449、F450、F451、F452、F453.

|                                             |                                               |      |
|---------------------------------------------|-----------------------------------------------|------|
| F304 S curve beginning stage proportion (%) | Setting range: 2.0~50.0                       | 30.0 |
| F305 S curve ending stage proportion (%)    | Setting range: 2.0~50.0                       | 30.0 |
| F306 Accel/decel mode                       | Setting range: 0: Straight-line<br>1: S curve | 0    |

Please refer to Fig 5-9 about S curve accel/decel:

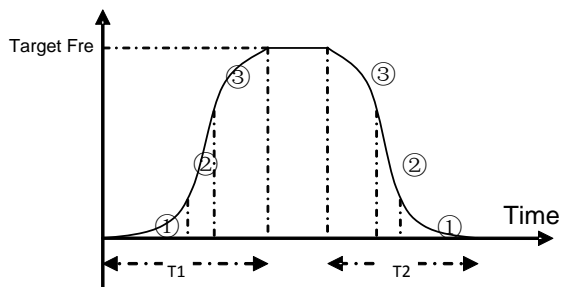

Fig 6-9 S curve acceleration /deceleration

T1 is the acceleration time from present frequency to target frequency.

T2 is the deceleration time from present frequency to target frequency.

During the acceleration process, in the ① stage, the acceleration slope is bigger gradually, in the ② stage, the acceleration slope is constant, in the ③ stage, the acceleration slope is weaker gradually.

|                                         |                          |                 |
|-----------------------------------------|--------------------------|-----------------|
| F307 Characteristic frequency 1 (Hz)    | Setting range: F112~F111 | Mfr's value: 10 |
| F308 Characteristic frequency 2 (Hz)    |                          | Mfr's value: 50 |
| F309 Characteristic frequency width (%) | Setting range: 0~100     | Mfr's value: 50 |

When F300=2, 3, F301=2, 3 and F302=2, 3 and token characteristic frequency is selected, this group function codes set characteristic frequency and its width. For example: setting F301=2, F307=10, F309=10, when frequency is higher than F307, DO1 outputs ON signal. When frequency is lower than  $(10-10*10\%) = 9\text{Hz}$ , DO1 outputs OFF signal.

|                                       |                         |                            |
|---------------------------------------|-------------------------|----------------------------|
| F310 Characteristic current (A)       | Setting range: 0~5000.0 | Mfr's value: Rated current |
| F311 Characteristic current width (%) | Setting range: 0~100    | Mfr's value: 10            |

When F300=17 and F301=17 and F302=17 and token characteristic current is selected, this group function codes set characteristic current and its width.

For example: setting F301=17, F310=100, F311=10, when inverter current is higher than F310, DO1 outputs ON signal. When inverter current is lower than  $(100-100*10\%) = 90\text{A}$ , DO1 outputs OFF signal.

|                                       |                          |                   |
|---------------------------------------|--------------------------|-------------------|
| F312 Frequency arrival threshold (Hz) | Setting range: 0.00~5.00 | Mfr's value: 0.00 |
|---------------------------------------|--------------------------|-------------------|

When F300=15 and F301=15, threshold range is set by F312.

For example: when F301=15, target frequency is 20HZ and F312=2, the running frequency reaches 18Hz (20-2), ON signal is output by DO1 until the running frequency reaches target frequency.

|                                |                           |                   |
|--------------------------------|---------------------------|-------------------|
| F313 Count frequency divisions | Setting range: 1~65000    | Mfr's value: 1    |
| F314 Set count value           | Setting range: F315~65000 | Mfr's value: 1000 |

|                             |                       |                   |
|-----------------------------|-----------------------|-------------------|
| F315 Designated count value | Setting range: 1~F314 | Mfr's value : 500 |
|-----------------------------|-----------------------|-------------------|

Count frequency divisions refer to the ratio of actual pulse input and inverter's count times, i.e.,

$$\text{Inverter's Count Times} = \frac{\text{Actual Pulse Input}}{\text{Count Frequency Division}}$$

e.g. when F313=3, inverter will count once for every 3 inputs of external pulse.

Set count values refer to a count width pulse output by the output terminal (DO1 terminal or relay) programmed with "reaching the set count values" function when a certain number of pulses are input from DI1. Count will restart after the count value reaches "set times".

As shown in Fig 6-10: if F313=1, F314=8, F301=8, DO1 will output an instruction signal when DI1 inputs the 8<sup>th</sup> pulse.

Designated count values refer to an pulse output by the output terminal (DO1 or RELAY terminal) programmed with "reaching the set count values" function when a certain number of pulses are input from DI1, until count value reaches the "set times".

As shown in Fig 6-10: if F313=1, F314=8, F315=5, F300=9, relay will output an instruction signal when DI1 inputs the 5<sup>th</sup> pulse, relay will output an instruction signal until reaching "set count times 8".

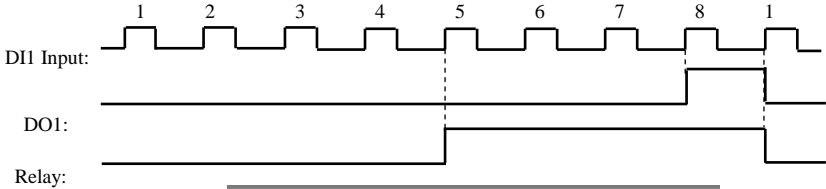

**Fig 6-10 Set Count times & Designated Count Times**

6.3.2 Digital multifunctional input terminals

|                                    |                                                                                                                                              |                 |
|------------------------------------|----------------------------------------------------------------------------------------------------------------------------------------------|-----------------|
| F316 DI1 terminal function setting | Setting range:<br>0: no function;<br>1: running terminal;<br>2: stop terminal;                                                               | Mfr's value: 11 |
| F317 DI2 terminal function setting | 3: multi-stage speed terminal 1;<br>4: multi-stage speed terminal 2;<br>5: multi-stage speed terminal 3;<br>6: multi-stage speed terminal 4; | Mfr's value: 9  |
| F318 DI3 terminal function setting | 7: reset terminal;<br>8: free stop terminal;<br>9: external emergency stop terminal;                                                         | Mfr's value: 15 |
| F319 DI4 terminal function setting | 10: acceleration/deceleration forbidden terminal;<br>11: forward run jogging;<br>12: reverse run jogging;                                    | Mfr's value: 16 |
| F320 DI5 terminal function setting | 13: UP frequency increasing terminal;<br>14: DOWN frequency decreasing terminal;<br>15: "FWD" terminal;                                      | Mfr's value: 7  |
| F321 DI6 terminal function setting | 16: "REV" terminal;<br>17: three-line type input "X" terminal;                                                                               | Mfr's value: 8  |

|                                    |                                                                                                                                                                                                                                                                                                                                                                                                                                                                                                                                                                                                                                                                                                                                                                                                                |                |
|------------------------------------|----------------------------------------------------------------------------------------------------------------------------------------------------------------------------------------------------------------------------------------------------------------------------------------------------------------------------------------------------------------------------------------------------------------------------------------------------------------------------------------------------------------------------------------------------------------------------------------------------------------------------------------------------------------------------------------------------------------------------------------------------------------------------------------------------------------|----------------|
| F322 DI7 terminal function setting | 18: acceleration/deceleration time switchover 1;<br>19: Reserved;                                                                                                                                                                                                                                                                                                                                                                                                                                                                                                                                                                                                                                                                                                                                              | Mfr's value: 0 |
| F323 DI8 terminal function setting | 20: switchover between speed and torque<br>21: frequency source switchover terminal;<br>22: Count input terminal;<br>23: Count reset terminal<br>24: clear traverse status<br>25: Traverse operating mode is valid.<br>26: yarn broken<br>27: intertwining yarn<br>28: crawl-positioning signal<br>29: clear actual yarn length and traverse status<br>30: Water lack signal; 31: Signal of water<br>32: Fire pressure switchover;<br>33: Emergency fire control<br>34: Acceleration / deceleration switchover 2<br>37: Common-open PTC heat protection<br>38: Common-close PTC heat protection<br>41: DI pre-alarm current enable<br>42: oPEn protection terminal.<br>49: PID paused<br>51: Motor switchover<br>53: Watchdog<br>54: Frequency reset<br>60: Communication timeout 2<br>61: Start-stop terminal | Mfr's value: 0 |

This parameter is used for setting the corresponding function for multifunctional digital input terminal.

Both free stop and external emergency stop of the terminal have the highest priority.

When pulse given is selected, DI1 terminal is set as pulse signal input terminal automatically.

**Note: 30 kW inverter and below 22kW has 6 multifunctional digital input terminals DI1~DI6.**

**Table 6-3 Instructions for digital multifunctional input terminal**

| Value | Function                    | Instructions                                                                                                                                                                                                                           |
|-------|-----------------------------|----------------------------------------------------------------------------------------------------------------------------------------------------------------------------------------------------------------------------------------|
| 0     | No function                 | Even if signal is input, inverter will not work. This function can be set by undefined terminal to prevent mistake action.                                                                                                             |
| 1     | Running terminal            | When running command is given by terminal or terminals combination and this terminal is valid, inverter will run. This terminal has the same function with "run" key in keypad.                                                        |
| 2     | Stop terminal               | When stop command is given by terminal or terminals combination and this terminal is valid, inverter will stop. This terminal has the same function with "stop" key in keypad.                                                         |
| 3     | Multistage speed terminal 1 | 15-stage speed is realized by combination of this group of terminals. See table 5-6.                                                                                                                                                   |
| 4     | Multistage speed terminal 2 |                                                                                                                                                                                                                                        |
| 5     | Multistage speed terminal 3 |                                                                                                                                                                                                                                        |
| 6     | Multistage speed terminal 4 |                                                                                                                                                                                                                                        |
| 7     | Reset terminal              | This terminal has the same function with "reset" key in keypad. Long-distance malfunction reset can be realized by this function.                                                                                                      |
| 8     | Free stop terminal          | Inverter closes off output and motor stop process is not controlled by inverter. This mode is often used when load has big inertia or there are no requirements for stop time. This mode has the same function with free stop of F209. |

|    |                                              |                                                                                                                                                                                                                                                                    |
|----|----------------------------------------------|--------------------------------------------------------------------------------------------------------------------------------------------------------------------------------------------------------------------------------------------------------------------|
| 9  | External emergency stop terminal             | When external malfunction signal is given to inverter, malfunction will occur and inverter will stop.                                                                                                                                                              |
| 10 | Acceleration/deceleration forbidden terminal | Inverter will not be controlled by external signal (except for stop command), and it will run at the current output frequency.                                                                                                                                     |
| 11 | forward run jogging                          | Forward jogging running and reverse jogging running. Refer to F124, F125 and F126 for jogging running frequency, jogging acceleration/deceleration time.                                                                                                           |
| 12 | reverse run jogging                          |                                                                                                                                                                                                                                                                    |
| 13 | UP frequency increasing terminal             | When frequency source is set by digital given, the setting frequency can be adjusted which rate is set by F211.                                                                                                                                                    |
| 14 | DOWN frequency decreasing terminal           |                                                                                                                                                                                                                                                                    |
| 15 | “FWD” terminal                               | When start/stop command is given by terminal or terminals combination, running direction of inverter is controlled by external terminals.                                                                                                                          |
| 16 | “REV” terminal                               |                                                                                                                                                                                                                                                                    |
| 17 | Three-line input “X” terminal                | “FWD”、“REV”、“CM” terminals realize three-line control. See F208 for details.                                                                                                                                                                                       |
| 18 | acceleration/deceleration time switchover 1  | Please refer to Table 5-4.                                                                                                                                                                                                                                         |
| 19 | Reserved                                     | Reserved                                                                                                                                                                                                                                                           |
| 20 | Reserved                                     | Reserved                                                                                                                                                                                                                                                           |
| 21 | frequency source switchover terminal         | When F207=2, main frequency source and accessory frequency source can be switched over by frequency source switching terminal. When F207=3, X and (X + Y) can be switched over by frequency source switching terminal.                                             |
| 22 | Count input terminal                         | Built-in count pulse input terminal.                                                                                                                                                                                                                               |
| 23 | Count reset terminal                         | Reset terminal count value to zero.                                                                                                                                                                                                                                |
| 24 | clear traverse status                        | When this terminal is valid, traverse status will be cleared in the stop status. After inverter runs again, the traverse process will be repeated again.                                                                                                           |
| 25 | Traverse operating mode is valid             | When F235≠0 and F237=1, this terminal is used to control start/stop of traverse operating mode. If inverter is in the running status and this terminal is valid, traverse operating mode starts.                                                                   |
| 26 | yarn broken                                  | In the mode of traverse operating, if this terminal is valid, inverter will stop. If crawl-positioning function is valid, inverter will run to crawling frequency, and positioning, inverter will stop. When this terminal is invalid, inverter will run normally. |
| 27 | intertwining yarn                            |                                                                                                                                                                                                                                                                    |
| 28 | crawl-positioning signal                     | During the process of crawl-positioning and after the waiting time F253, if the terminal is valid, inverter will stop.                                                                                                                                             |
| 29 | clear actual yarn length and traverse status | This terminal is used to clear actual yarn length and traverse status.                                                                                                                                                                                             |
| 30 | Water lack signal                            | When PID control is valid and FA26=1, this function is valid. While lack of water, inverter will be in the protection state.                                                                                                                                       |
| 31 | Signal of water                              | When PID control is valid and FA26=1, this function is valid. If water is enough, inverter will reset automatically.                                                                                                                                               |
| 32 | Fire pressure switchover                     | When PID control is valid and this terminal is valid, the setting value of PID switches into fire pressure given (FA58).                                                                                                                                           |
| 33 | Emergency fire control                       | When emergency fire mode (FA59) is valid, inverter will be in emergency fire mode.                                                                                                                                                                                 |
| 34 | Acceleration / deceleration switchover 2     | Please refer to Table 5-4.                                                                                                                                                                                                                                         |



|    |                                  |                                                                                                                                                                                                                                                                                            |
|----|----------------------------------|--------------------------------------------------------------------------------------------------------------------------------------------------------------------------------------------------------------------------------------------------------------------------------------------|
| 37 | Common-open PTC heat protection  | When this function is valid, common-open heat relay is externally connected. When common-open contact is closed and inverter is in the running status, inverter will trip into OH1.                                                                                                        |
| 38 | Common-close PTC heat protection | When this function is valid, common-close heat relay is externally connected. When common-close contact is open and inverter is in the running status, inverter will trip into OH1.                                                                                                        |
| 41 | DI pre-alarm current enable      | When this function is valid, inverter will test running current.                                                                                                                                                                                                                           |
| 49 | PID paused                       | PID adjustment is invalid temporarily.                                                                                                                                                                                                                                                     |
| 51 | Motor switchover                 | When FE00=2 and this function is valid, switching to the second motor.                                                                                                                                                                                                                     |
| 53 | Watchdog                         | During the time set by F326 elapses without an impulse being registered, inverter will trip into Err6, and inverter will stop according to stop mode set by F327.                                                                                                                          |
| 54 | Frequency reset                  | In the application 4, if the function is valid, target frequency will change to the value set by F113.                                                                                                                                                                                     |
| 60 | Communication timeout 2          | When F907>0, and receiving the previous data, if after the time set by F907, the next data is not received, inverter will output communication timeout signal. The timeout signal will be cleared by this terminal, and after receiving correct data, inverter will accumulate time again. |
| 61 | Start-stop terminal              | When the function is invalid, it is stop terminal. When the function is valid, it is start terminal.                                                                                                                                                                                       |

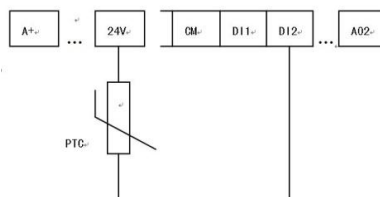

**Fig 6-6 PTC heat protection**

When the coding switch is in the end of “NPN”, PTC resistor should be connected between CM and DIx terminal. When the coding switch is in the end of “PNP”, PTC resistor should be connected between DIx and 24V. The recommended resistor value is 16.5K.

Because the precision of external PTC has some differences with optocoupler consistency, protection value precision will be bad, heat protection relay is suggested to be used.

Table 6-4 Accel/decel selection

| Accel/decel switchover<br>2 (34) | Accel/decel switchover<br>1 (18) | Present accel/decel time    | Related parameters |
|----------------------------------|----------------------------------|-----------------------------|--------------------|
| 0                                | 0                                | The first accel/decel time  | F114, F115         |
| 0                                | 1                                | The second accel/decel time | F116, F117         |
| 1                                | 0                                | The third accel/decel time  | F277, F278         |
| 1                                | 1                                | The fourth accel/decel time | F279, F280         |

**Table 6-6 Instructions for multistage speed**

| K4 | K3 | K2 | K1 | Frequency setting    | Parameters                    |
|----|----|----|----|----------------------|-------------------------------|
| 0  | 0  | 0  | 0  | None                 | None                          |
| 0  | 0  | 0  | 1  | Multi-stage speed 1  | F504/F519/F534/F549/F557/F565 |
| 0  | 0  | 1  | 0  | Multi-stage speed 2  | F505/F520/F535/F550/F558/F566 |
| 0  | 0  | 1  | 1  | Multi-stage speed 3  | F506/F521/F536/F551/F559/F567 |
| 0  | 1  | 0  | 0  | Multi-stage speed 4  | F507/F522/F537/F552/F560/F568 |
| 0  | 1  | 0  | 1  | Multi-stage speed 5  | F508/F523/F538/F553/F561/F569 |
| 0  | 1  | 1  | 0  | Multi-stage speed 6  | F509/F524/F539/F554/F562/F570 |
| 0  | 1  | 1  | 1  | Multi-stage speed 7  | F510/F525/F540/F555/F563/F571 |
| 1  | 0  | 0  | 0  | Multi-stage speed 8  | F511/F526/F541/F556/F564/F572 |
| 1  | 0  | 0  | 1  | Multi-stage speed 9  | F512/F527/F542/F573           |
| 1  | 0  | 1  | 0  | Multi-stage speed 10 | F513/F528/F543/F574           |
| 1  | 0  | 1  | 1  | Multi-stage speed 11 | F514/F529/F544/F575           |
| 1  | 1  | 0  | 0  | Multi-stage speed 12 | F515/F530/F545/F576           |
| 1  | 1  | 0  | 1  | Multi-stage speed 13 | F516/F531/F546/F577           |
| 1  | 1  | 1  | 0  | Multi-stage speed 14 | F517/F532/F547/F578           |
| 1  | 1  | 1  | 1  | Multi-stage speed 15 | F518/F533/F548/F579           |

**Note: 1. K4 is multi-stage speed terminal 4, K3 is multi-stage speed terminal 3, K2 is multi-stage speed terminal 2, K1 is multi-stage speed terminal 1. And 0 stands for OFF, 1 stands for ON.**

**2. 0=OFF, 1=ON**

**3. The setting of this table is valid when F580=0.**

|                                             |                                                            |                   |
|---------------------------------------------|------------------------------------------------------------|-------------------|
| F324 Free stop terminal logic               | Setting range:<br>0: positive logic (valid for low level); | Mfr's value: 0    |
| F325 External emergency stop terminal logic | 1: negative logic (valid for high level)                   | Mfr's value: 0    |
| F326 Watchdog time                          | Setting range: 0.0: Invalid<br>0.1~30000                   | Mfr's value: 10.0 |
| F327 Stop mode                              | Setting range:<br>0: Free to stop 1: Deceleration to stop  | Mfr's value : 0   |
| F328 Terminal filtering times               | Setting range: 1~100                                       | Mfr's value: 10   |

When multi-stage speed terminal is set to free stop terminal (8) and external emergency stop terminal (9), terminal logic level is set by this group of function codes. When F324=0 and F325=0, positive logic and low level is valid, when F324=1 and F325=1, negative logic and high level is valid.

|                                    |                                    |                |
|------------------------------------|------------------------------------|----------------|
| F329 Run command of start terminal | Setting range: 0: Valid 1: Invalid | Mfr's value: 0 |
|------------------------------------|------------------------------------|----------------|

When F329=0, after power on, if start terminals (running terminal, forward jogging, reverse jogging, FWD, REV, 3-line X input enable) is valid, inverter will start running directly.

When F329=1, after power on, if start terminals (running terminal, forward jogging, reverse jogging, FWD, REV, 3-line X input enable) is valid, inverter will start running after disconnect start terminal first and enable it again.

**Diagnostics and simulation functions**

F330 Diagnostics of DIX terminal

Read only

F330 is used to display the diagnostics of DIX terminals.

Please refer to Fig 6-12 about the DIX terminals diagnostics in the first digitron.

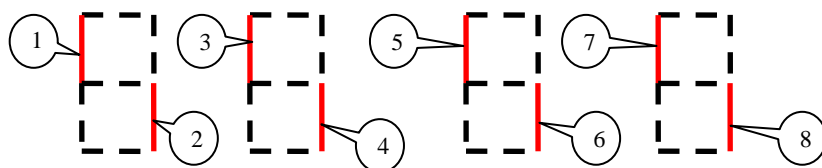

Fig 6-12 Status of digital input terminal

The dotted line means this part of digitron is red.

For example, in the first digitron, the upper part of digitron is red, it means D11 terminal is invalid. The lower part of digitron is red, it means D12 is valid. The four digitrons stands for the status of D11-D18 terminals

Please refer to Fig 6-13 about four-line LCD interface. The solid-line box and dotted-line box indicate the invalid and valid respectively.



Figure 6-13 Status of digital input terminals

Set F645=22, press "SET", switch interface by "FUN" key to display 8 boxes. Short connecting to D11~D18, terminals are valid if number turns from 0 to 1, and eight dotted-line boxes are displayed; Terminals are invalid if number does not turn to 1, and eight solid-line boxes are displayed.

If user wants to see the detailed status for each terminal, set the function code as F330, press "SET" to enter diagnosis interface, which is showed below.

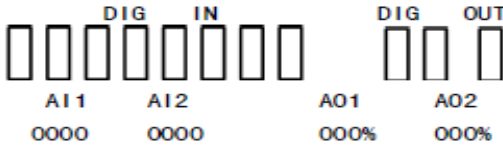

The first line indicates digital input, digital output; First eight boxes in the second line indicate the state of DI terminals, terminals from left to right are DI1~DI8, solid-line box is the state showed as above when terminal is invalid; Black box is displayed when terminal is valid. E.g. If all 8 terminals are valid, will be displayed.

The last three boxes represent the terminal output status of DO1, DO2 and relay, which display mode is the same as DI terminals. E.g. If 3 terminals are valid at same time, will be displayed.

The third line indicates the name of AI1, AI2 and AO1, AO2. The value displayed in fourth line correspond to the content of third line.

E.g. AI1 AI2 AO1 AO2  
2010 0000 000% 000%

It means the value of AI1 is 2010, so are the rest three values.

After checking diagnosis interface, if user needs to exit interface, press “FUN” key to enter first-level menu.

Analog input monitoring, the value of analog is displayed by 0~4095.

|                     |  |           |
|---------------------|--|-----------|
| F331Monitoring AI1  |  | Read only |
| F332 Monitoring AI2 |  | Read only |
| F333 Monitoring AI3 |  | Read only |

Relay/Digital output simulation

|      |                         |                                                           |                |
|------|-------------------------|-----------------------------------------------------------|----------------|
| F335 | Relay output simulation | Setting range:<br>0: Output active<br>1: Output inactive. | Mfr's value: 0 |
| F336 | DO1 output simulation   |                                                           | Mfr's value: 0 |
| F337 | DO2 output simulation   |                                                           | Mfr's value: 0 |

Take an example of DO1 output simulation, when inverter is in the stop status and enter F336, press the UP key, the DO1 terminal is valid. Relax the UP key, DO1 remains valid status. After quitting F336, DO1 will revert to initial output status.

4. Analog output simulation

|      |                       |                       |                |
|------|-----------------------|-----------------------|----------------|
| F338 | AO1 output simulation | Setting range: 0~4095 | Mfr's value: 0 |
| F339 | AO2 output simulation | Setting range: 0~4095 | Mfr's value: 0 |

When inverter is in the stop status, and enter F338 or F339, press the UP key, the output analog will increase, and when press the DOWN key, the output analog will decrease. If relax the key, analog output remains stable. After quitting the parameters, AO1 and AO2 will revert to initial output status.

|                                           |                                                                                                                                                                                                                                                          |                |
|-------------------------------------------|----------------------------------------------------------------------------------------------------------------------------------------------------------------------------------------------------------------------------------------------------------|----------------|
| F340 Selection of terminal negative logic | Setting range:<br>0: Invalid                    1: DI1 negative logic<br>2: DI2 negative logic    4: DI3 negative logic<br>8: DI4 negative logic    16: DI5 negative logic<br>32: DI6 negative logic   64: DI6 negative logic<br>128: DI8 negative logic | Mfr's value: 0 |
|-------------------------------------------|----------------------------------------------------------------------------------------------------------------------------------------------------------------------------------------------------------------------------------------------------------|----------------|

For example: if user wants to set DI1 and DI4 to negative logic, please set F340=1+8=9.

|      |                       |                           |                   |
|------|-----------------------|---------------------------|-------------------|
| F343 | Delay time of DI1 ON  | Setting range: 0.00~99.99 | Mfr's value: 0.00 |
| F344 | Delay time of DI2 ON  | Setting range: 0.00~99.99 | Mfr's value: 0.00 |
| F345 | Delay time of DI3 ON  | Setting range: 0.00~99.99 | Mfr's value: 0.00 |
| F346 | Delay time of DI4 ON  | Setting range: 0.00~99.99 | Mfr's value: 0.00 |
| F347 | Delay time of DI5 ON  | Setting range: 0.00~99.99 | Mfr's value: 0.00 |
| F348 | Delay time of DI6 ON  | Setting range: 0.00~99.99 | Mfr's value: 0.00 |
| F349 | Delay time of DI7 ON  | Setting range: 0.00~99.99 | Mfr's value: 0.00 |
| F350 | Delay time of DI8 ON  | Setting range: 0.00~99.99 | Mfr's value: 0.00 |
| F351 | Delay time of DI1 OFF | Setting range: 0.00~99.99 | Mfr's value: 0.00 |
| F352 | Delay time of DI2 OFF | Setting range: 0.00~99.99 | Mfr's value: 0.00 |
| F353 | Delay time of DI3 OFF | Setting range: 0.00~99.99 | Mfr's value: 0.00 |
| F354 | Delay time of DI4 OFF | Setting range: 0.00~99.99 | Mfr's value: 0.00 |
| F355 | Delay time of DI5 OFF | Setting range: 0.00~99.99 | Mfr's value: 0.00 |
| F356 | Delay time of DI6 OFF | Setting range: 0.00~99.99 | Mfr's value: 0.00 |
| F357 | Delay time of DI7 OFF | Setting range: 0.00~99.99 | Mfr's value: 0.00 |
| F358 | Delay time of DI8 OFF | Setting range: 0.00~99.99 | Mfr's value: 0.00 |

|      |                       |                                    |                |
|------|-----------------------|------------------------------------|----------------|
| F359 | Stop command priority | Setting range: 0: Invalid 1: Valid | Mfr's value: 0 |
|------|-----------------------|------------------------------------|----------------|

When F359=1, if inverter get stop command when run command is valid, inverter will stop first. Inverter will start again only after disconnecting the start terminal first and connect it again.

|      |                            |                                                                                           |                |
|------|----------------------------|-------------------------------------------------------------------------------------------|----------------|
| F360 | DO terminal negative logic | Setting range: 0: Invalid<br>1: DO1 negative logic<br>2: DO2 negative logic<br>4: Relay 1 | Mfr's value: 0 |
|------|----------------------------|-------------------------------------------------------------------------------------------|----------------|

If DO1 is negative logic, F360=1. If DO2 is negative logic, F360=2. If relay 1 is negative logic, F360=4. If DO1 and DO2 are negative logic, then F360=1+2=3..

## 6.4 Analog Input and Output

E2000 series inverters have 2 analog input channels and 2 analog output channels. AI3 input channel is inside input channel for potentiometer on the keypad panel.

|      |                                                    |                           |                    |
|------|----------------------------------------------------|---------------------------|--------------------|
| F400 | Lower limit of AI1 channel input (V)               | Setting range: 0.00~F402  | Mfr's value: 0.04  |
| F401 | Corresponding setting for lower limit of AI1 input | Setting range: 0~2.00     | Mfr's value: 1.00  |
| F402 | Upper limit of AI1 channel input (V)               | Setting range: F400~10.00 | Mfr's value: 10.00 |
| F403 | Corresponding setting for upper limit of AI1 input | Setting range: 0.00 ~2.00 | Mfr's value: 2.00  |
| F404 | AI1 channel proportional gain K1                   | Setting range: 0.0~10.0   | Mfr's value: 1.0   |
| F405 | AI1 filtering time constant (S)                    | Setting range: 0.10~10.00 | Mfr's value: 0.10  |

In the mode of analog speed control, sometimes it requires adjusting coincidence relation among upper limit and lower limit of input analog, analog changes and output frequency, to achieve a satisfactory speed control effect.

- Upper and lower limit of analog input are set by F400 and F402.
- For example: when F400=1, F402=8, if analog input voltage is lower than 1V, system judges it as 0. If input voltage is higher than 8V, system judges it as 10V (Suppose analog channel selects 0-10V). If Max frequency F111 is set to 50Hz, the output frequency corresponding to 1-8V is 0-50Hz.
- The filtering time constant is set by F405.

The greater the filtering time constant is, the more stable for the analog testing. However, the precision may decrease to a certain extent. It may require appropriate adjustment according to actual application.

- Channel proportional gain is set by F404.
- If 1V corresponds to 10Hz and F404=2, then 1V will correspond to 20Hz.
- Corresponding setting for upper / lower limit of analog input are set by F401 and F403.

If Max frequency F111 is 50Hz, analog input voltage 0-10V can correspond to output frequency from -50Hz to 50Hz by setting this group function codes. Please set F401=0 and F403=2, then 0V corresponds to -50Hz, 5V corresponds to 0Hz and 10V corresponds to 50Hz. The unit of corresponding setting for upper / lower limit of input is in percentage (%). If the value is greater than 1.00, it is positive; if the value is less than 1.00, it is negative. (e.g. F401=0.5 represents -50%).

If the running direction is set to forward running by F202, then 0-5V corresponding to the minus frequency will cause reverse running, or vice versa.

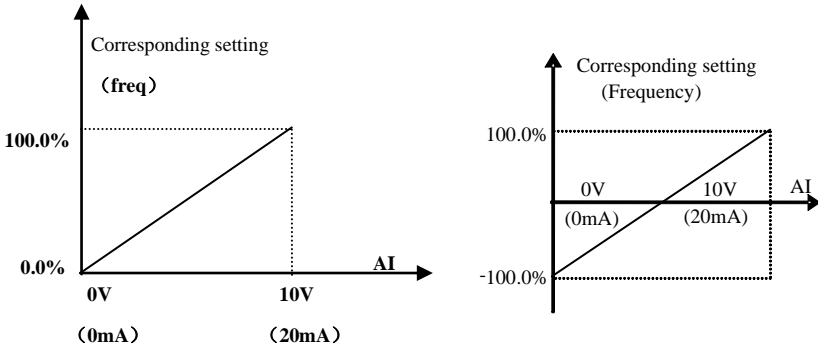

**Fig 6-14** correspondence of analog input to setting

The unit of corresponding setting for upper / lower limit of input is in percentage (%). If the value is greater than 1.00, it is positive; if the value is less than 1.00, it is negative. (e.g. F401=0.5 represents -50%). The corresponding setting benchmark: in the mode of combined speed control, analog is the accessory frequency and the setting benchmark for range of accessory frequency which relates to main frequency is "main frequency X"; corresponding setting benchmark for other cases is the "max

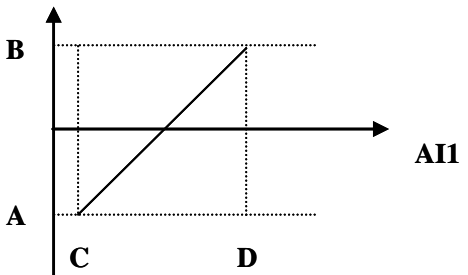

frequency", as illustrated in the right figure:

A= (F401-1)\* setting value

B= (F403-1)\* setting value

C= F400 D= F402

|      |                                                    |                           |                    |
|------|----------------------------------------------------|---------------------------|--------------------|
| F406 | Lower limit of AI2 channel input (V)               | Setting range: 0.00~F408  | Mfr's value: 0.04  |
| F407 | Corresponding setting for lower limit of AI2 input | Setting range: 0.00~2.00  | Mfr's value: 1.00  |
| F408 | Upper limit of AI2 channel input (V)               | Setting range: F406~10.00 | Mfr's value: 10.00 |
| F409 | Corresponding setting for upper limit of AI2 input | Setting range: 0.00~2.00  | Mfr's value: 2.00  |
| F410 | AI2 channel proportional gain K2                   | Setting range: 0.0~10.0   | Mfr's value: 1.0   |
| F411 | AI2 filtering time constant (S)                    | Setting range: 0.01~10.00 | Mfr's value: 0.10  |
| F412 | Lower limit of AI3 channel input (V)               | Setting range: 0.00~F414  | Mfr's value: 0.05  |
| F413 | Corresponding setting for lower limit of AI3 input | Setting range: 0.00~2.00  | Mfr's value: 1.00  |
| F414 | Upper limit of AI3 channel input (V)               | Setting range: F412~10.00 | Mfr's value: 10.00 |
| F415 | Corresponding setting for upper limit of AI3 input | Setting range: 0.00~2.00  | Mfr's value: 2.00  |
| F416 | AI3 channel proportional gain K1                   | Setting range: 0.0~10.0   | Mfr's value: 1.0   |
| F417 | AI3 filtering time constant (S)                    | Setting range: 0.01~10.00 | Mfr's value: 0.10  |

The function of AI2 and AI3 is the same with AI1.

|      |                                       |                          |                   |
|------|---------------------------------------|--------------------------|-------------------|
| F418 | AI1 channel 0Hz voltage dead zone (V) | Setting range: 0.00~1.00 | Mfr's value: 0.00 |
| F419 | AI2 channel 0Hz voltage dead zone (V) | Setting range: 0.00~1.00 | Mfr's value: 0.00 |
| F420 | AI3 channel 0Hz voltage dead zone (V) | Setting range: 0.00~1.00 | Mfr's value: 0.00 |

Analog input voltage 0-5V can correspond to output frequency -50Hz-50Hz (2.5V corresponds to 0Hz) by setting the function of corresponding setting for upper / lower limit of analog input. The group function codes of F418, F419 and F420 set the voltage range corresponding to 0Hz. For example, when F418=0.5, F419=0.5 and F420=0.5, the voltage range from (2.5-0.5=2) to (2.5+0.5=3) corresponds to 0Hz. So if F418=N, F419=N and F420=N, then 2.5±N should correspond to 0Hz. If the voltage is in this range, inverter will output 0Hz. 0HZ voltage dead zone will be valid when corresponding setting for lower limit of input is less than 1.00. E2000 series inverters have two analog output channels.

|                              |                                                                                                        |                |
|------------------------------|--------------------------------------------------------------------------------------------------------|----------------|
| F421 Panel selection         | Setting range:<br>1: Local/ Remote keypad panel auto switch<br>2: local keypad + remote control keypad | Mfr's value: 1 |
| F422 Potentiometer selection | Setting range:<br>0: Potentiometer in local panel<br>1: Potentiometer in remote control panel          | Mfr's value: 0 |

When F421 is set to 0, local keypad panel is working. When F421 is set to 1, remote control keypad panel is working, and local keypad panel will be invalid for saving energy.

F422 is used to select potentiometer, which is only suitable for LED keypad.

When F422 is set to 0, the potentiometer in local LED panel is valid. When F422 is set to 1, the potentiometer in remote LED keypad is valid.

The remote control panel is connected by 8-cores net cable.

|                       |                                                               |                |
|-----------------------|---------------------------------------------------------------|----------------|
| F423 AO1 output range | Setting range:<br>0: 0~5V;<br>1: 0~10V or 0~20mA<br>2: 4~20mA | Mfr's value: 1 |
|-----------------------|---------------------------------------------------------------|----------------|

|      |                                          |                          |                    |
|------|------------------------------------------|--------------------------|--------------------|
| F424 | AO1 lowest corresponding frequency (Hz)  | Setting range: 0.0~F425  | Mfr's value: 0.05  |
| F425 | AO1 highest corresponding frequency (Hz) | Setting range: F424~F111 | Mfr's value: 50.00 |
| F426 | AO1 output compensation (%)              | Setting range: 0~120     | Mfr's value: 100   |

· AO1 output range is selected by F423. When F423=0, AO1 output range selects 0-5V, and when F423=1, AO1 output range selects 0-10V or 0-20mA. When F423=2, AO1 output range selects 4-20mA (When AO1 output range selects current signal, please turn the switch J5 to "I" position.)

· Correspondence of output voltage range (0-5V or 0-10V) to output frequency is set by F424 and F425. For example, when F423=0, F424=10 and F425=120, analog channel AO1 outputs 0-5V and the output frequency is 10-120Hz.

· AO1 output compensation is set by F426. Analog excursion can be compensated by setting F426.

|      |                                          |                                         |                    |
|------|------------------------------------------|-----------------------------------------|--------------------|
| F427 | AO2 output range                         | Setting range:<br>0: 0~20mA; 1: 4~20 mA | Mfr's value: 0     |
| F428 | AO2 lowest corresponding frequency (Hz)  | Setting range: 0.0~F429                 | Mfr's value: 0.05  |
| F429 | AO2 highest corresponding frequency (Hz) | Setting range: F428~F111                | Mfr's value: 50.00 |
| F430 | AO2 output compensation (%)              | Setting range: 0~120                    | Mfr's value: 100   |

The function of AO2 is the same as AO1, but AO2 will output current signal, current signal of 0-20mA and 4-20mA could be selected by F427.

|      |                                    |                                                                                                                                                                                                                                                                                         |                |
|------|------------------------------------|-----------------------------------------------------------------------------------------------------------------------------------------------------------------------------------------------------------------------------------------------------------------------------------------|----------------|
| F431 | AO1 analog output signal selecting | Setting range:<br>0: Running frequency;<br>1: Output current;<br>2: Output voltage;<br>3: AI1 4: AI2<br>5: Input pulse<br>6: Output torque<br>7: Given by PC/PLC<br>8: Target frequency<br>9: Actual speed<br>10: Output torque 2<br>11: Reserved<br>12: Output power<br>13: DO2 output | Mfr's value: 0 |
| F432 | AO2 analog output signal selecting |                                                                                                                                                                                                                                                                                         | Mfr's value: 1 |

· Token contents output by analog channel are selected by F431 and F432. Token contents include running frequency, output current and output voltage.

· When output current is selected, analog output signal is from 0 to twofold rated current.

· When output voltage is selected, analog output signal is from 0V to rated output voltage.

· When actual speed is selected, the speed is actual speed in vector control mode. In the other mode, the speed is synchronous speed.

· 6: Output torque: indicating output torque absolute value.

· 10: output torque 2: when output torque is higher than 0, indicating present torque. When output torque is lower than 0, there is no output.

· 13: DO2 output: F302=1, F431=13, F423=1, and analog coding switch turns to voltage, after fault occurs, AO1 output 10V. After the fault is reset, AO1 output 0V. if coding switch turns to current, AO1 will output 0mA or 20mA.

|      |                                                            |                             |                   |
|------|------------------------------------------------------------|-----------------------------|-------------------|
| F433 | Corresponding current for full range of external voltmeter | Setting range:<br>0.01~5.00 | Mfr's value: 2.00 |
| F434 | Corresponding current for full range of external ammeter   |                             | Mfr's value: 2.00 |

· In case of F431=1 and AO1 channel for token current, F433 is the ratio of measurement range of external voltage type ammeter to rated current of the inverter.

· In case of F432=1 and AO2 channel for token current, F434 is the ratio of measurement range of external current type ammeter to rated current of the inverter.



For example: measurement range of external ammeter is 20A, and rated current of the inverter is 8A, then,  $F433=20/8=2.50$ .

|                                                                        |                             |                  |
|------------------------------------------------------------------------|-----------------------------|------------------|
| F435 Corresponding multiple of rated power for output max analog value | Setting range:<br>0.01~3.00 | Mfr's value:2.00 |
|------------------------------------------------------------------------|-----------------------------|------------------|

Analog output range is taken as 0.01~3.00 times of torque power.

|                                                                                 |                             |                   |
|---------------------------------------------------------------------------------|-----------------------------|-------------------|
| F436 Corresponding current multiple of rated torque for output max analog value | Setting range:<br>0.01~3.00 | Mfr's value: 3.00 |
|---------------------------------------------------------------------------------|-----------------------------|-------------------|

In vector control mode, analog is 0.01~3.00 times of torque current.

## 6.5 Pulse input/output

|                                                |                                              |                    |
|------------------------------------------------|----------------------------------------------|--------------------|
| F440 Min frequency of input pulse FI (KHz)     | Setting range: 0.00~F442                     | Mfr's value: 0.00  |
| F441 Corresponding setting of FI min frequency | Setting range:0.00~F443                      | Mfr's value: 1.00  |
| F442 Max frequency of input pulse FI (KHz)     | Setting range: F440~100.00                   | Mfr's value: 10.00 |
| F443 Corresponding setting of FI max frequency | Setting range:<br>Max (1.00, F441) ~2.00     | Mfr's value: 2.00  |
| F445 Filtering constant of FI input pulse      | Setting range: 0~1000                        | Mfr's value: 0     |
| F446 FI channel 0Hz frequency dead zone (KHz)  | Setting range: 0~F442<br>(Positive-Negative) | Mfr's value: 0.00  |

Min frequency of input pulse is set by F440 and max frequency of input pulse is set by F442.

For example: when F440=0K and F442=10K, and the max frequency is set to 50Hz, then input pulse frequency 0-10K corresponds to output frequency 0-50Hz.

Filtering time constant of input pulse is set by F445.

The greater the filtering time constant is, the more steady pulse measurement, but precision will be lower, so please adjust it according to the application situation.

Corresponding setting of min frequency is set by F441 and corresponding setting of max frequency is set by F443.

When the max frequency is set to 50Hz, pulse input 0-10K can correspond to output frequency -50Hz-50Hz by setting this group function codes. Please set F441 to 0 and F443 to 2, then 0K corresponds to -50Hz, 5K corresponds to 0Hz, and 10K corresponds to 50Hz. The unit of corresponding setting for max/min pulse frequency is in percentage (%). If the value is greater than 1.00, it is positive; if the value is less than 1.00, it is negative.

If the running direction is set to forward running by F202, 0-5K corresponding to the minus frequency will cause reverse running, or vice versa.

0 Hz frequency dead zone is set by F446.

Input pulse 0-10K can correspond to output frequency -50Hz~50Hz (5K corresponds to 0Hz) by setting the function of corresponding setting for max/min input pulse frequency. The function code F446 sets the input pulse range corresponding to 0Hz. For example, when F446=0.5, the pulse range from (5K-0.5K=4.5K) to (5K+0.5K=5.5K) corresponds to 0Hz. So if F446=N, then  $5 \pm N$  should correspond to 0Hz. If the pulse is in this range, inverter will output 0Hz.

0Hz voltage dead zone will be valid when corresponding setting for min pulse frequency is less than 1.00.

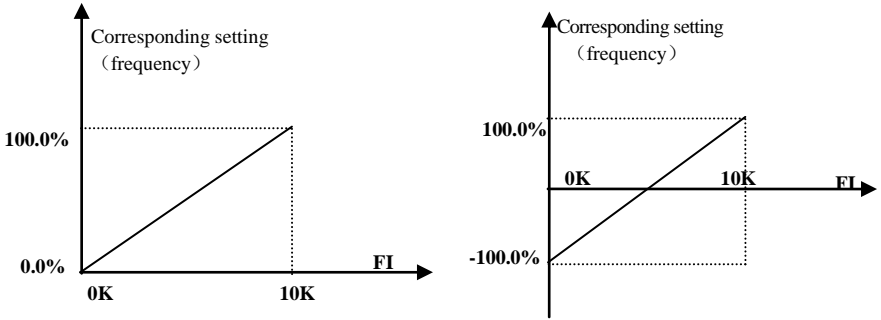

Fig 6-15 correspondence of pulse input and setting

The unit of corresponding setting for max/min input pulse frequency is in percentage (%). If the value is greater than 1.00, it is positive; if the value is less than 1.00, it is negative. (e.g. F441=0.5 represents -50%). The corresponding setting benchmark: in the mode of combined speed control, pulse input is the accessorial frequency and the setting benchmark for range of accessorial frequency which relates to main frequency (F205=1) is “main frequency X”; corresponding setting benchmark for other cases is the “max frequency”, as illustrated in the right figure:

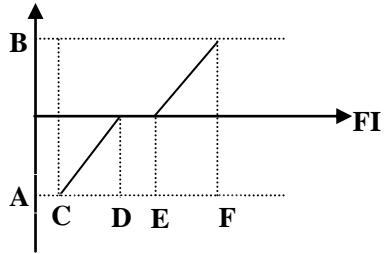

Fig 6-16 relationship between pulse input and setting value

A= (F441-1)\*setting benchmark  
 B= (F443-1)\*setting benchmark  
 C= F440 F= F442 (E-D)/2=F446

|                                                          |                                                                                                                                                                                      |                    |
|----------------------------------------------------------|--------------------------------------------------------------------------------------------------------------------------------------------------------------------------------------|--------------------|
| F449 Max frequency of output pulse FO (KHz)              | Setting range: 0.00~100.00                                                                                                                                                           | Mfr's value: 10.00 |
| F450 Zero bias coefficient of output pulse frequency (%) | Setting range: 0.0~100.0                                                                                                                                                             | Mfr's value: 0.0   |
| F451 Frequency gain of output pulse                      | Setting range: 0.00~10.00                                                                                                                                                            | Mfr's value: 1.00  |
| F453 Output pulse signal                                 | Setting range:<br>0: Running frequency<br>1: Output current<br>2: Output voltage<br>3: AI1 4: AI2<br>5: Input pulse<br>6: Output torque<br>7: Given by PC/PLC<br>8: Target frequency | Mfr's value: 0     |

· When DO1 is defined as high-speed pulse output terminal, the max frequency of output pulse is set by F449.

If “b” stands for zero bias coefficient, “k” stands for gain, “Y” stands for actual output of pulse frequency and “x” stands for standard output, then  $Y=Kx+b$ .

Standard output x is the token value corresponding to output pulse min/max frequency, which range is from zero to max value.

·100 percent of zero bias coefficient of output pulse frequency corresponds to the max output pulse

frequency (the set value of F449.)

Frequency gain of output pulse is set by F451. User can set it to compensate the deviation of output pulse. Output pulse token object is set by F453. For example: running frequency, output current and output voltage, etc. When output current is displayed, the range of token output is 0-2 times of rated current.

When output voltage is displayed, the range of token output is from 0-1.2 times of rated output voltage.

|      |                                          |                                                              |                   |
|------|------------------------------------------|--------------------------------------------------------------|-------------------|
| F460 | AI1 channel input mode                   | Setting range: 0: straight line mode<br>1: folding line mode | Mfr's value: 0    |
| F461 | AI2 channel input mode                   | Setting range: 0: straight line mode<br>1: folding line mode | Mfr's value: 0    |
| F462 | AI1 insertion point A1 voltage value (V) | Setting range: F400~F464                                     | Mfr's value: 2.00 |
| F463 | AI1 insertion point A1 setting value     | Setting range: 0.00~2.00                                     | Mfr's value: 1.20 |
| F464 | AI1 insertion point A2 voltage value (V) | Setting range: F462~F466                                     | Mfr's value: 5.00 |
| F465 | AI1 insertion point A2 setting value     | Setting range: 0.00~2.00                                     | Mfr's value: 1.50 |
| F466 | AI1 insertion point A3 voltage value (V) | Setting range: F464~F402                                     | Mfr's value: 8.00 |
| F467 | AI1 insertion point A3 setting value     | Setting range: 0.00~2.00                                     | Mfr's value: 1.80 |
| F468 | AI2 insertion point B1 voltage value (V) | Setting range: F406~F470                                     | Mfr's value: 2.00 |
| F469 | AI2 insertion point B1 setting value     | Setting range: 0.00~2.00                                     | Mfr's value: 1.20 |
| F470 | AI2 insertion point B2 voltage value (V) | Setting range: F468~F472                                     | Mfr's value: 5.00 |
| F471 | AI2 insertion point B2 setting value     | Setting range: 0.00~2.00                                     | Mfr's value: 1.50 |
| F472 | AI2 insertion point B3 voltage value (V) | Setting range: F470~F412                                     | Mfr's value: 8.00 |
| F473 | AI2 insertion point B3 setting value     | Setting range: 0.00~2.00                                     | Mfr's value: 1.80 |

When analog channel input mode selects straight-line, please set it according to the parameters from F400 to F429. When folding line mode is selected, three points A1(B1), A2(B2), A3(B3) are inserted into the straight line, each of which can set the according frequency to input voltage. Please refer to the following figure:

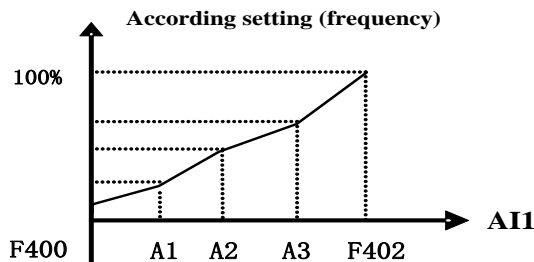

**Fig 6-17 Folding analog with setting value**

F400 and F402 are lower/upper limit of analog AI1 input. When F460=1, F462=2.00V, F463=1.4, F111=50, F203=1, F207=0, then A1 point corresponding frequency is  $(F463-1) * F111=20\text{Hz}$ , which means 2.00V corresponding to 20Hz. The other points can be set by the same way.

AI2 channel has the same setting way as AI1.

|      |                                |                                    |                    |
|------|--------------------------------|------------------------------------|--------------------|
| F477 | User-define speed control mode | Setting range: 0: Invalid 1: Valid | Mfr's value: 0     |
| F478 | Max limit of output frequency  | Setting range: F113~F111           | Mfr's value: 50.00 |

When F477=1, 3 kinds of control speed mode can be realized,  $K1*X-K2*Y$ ,  $K1*X+K2*Y-5V$ ,  $K1*X+K2*Y-5V$  (Y-5V) .

For example: if main frequency is given by AI1, auxiliary frequency is given by AI2, K1=3, K2=2,

| Speed control mode | F203 | F204 | F207 | F221 | F206 | F111   | F478  | Remarks                                                                        |
|--------------------|------|------|------|------|------|--------|-------|--------------------------------------------------------------------------------|
| 3*AI1-2*AI2        | 1    | 2    | 5    | -    | 67%  | 150.00 | 50.00 | F206=(K2÷K1)*100<br>F111=K1*50.00<br>F478 is max value of<br>output frequency. |
| 3*AI1+2*AI2-5V     | 1    | 2    | 6    | 25%  | 67%  | 150.00 | 50.00 |                                                                                |
| 3*AI1+2*(AI2-5V)   | 1    | 2    | 6    | 50%  | 67%  | 150.00 | 50.00 |                                                                                |

Note: the 3 kinds of speed control mode are valid only when the source of main frequency and auxiliary frequency are set according to F207.

## 6.6 Multi-stage Speed Control

The function of multi-stage speed control is equivalent to a built-in PLC in the inverter. This function can set running time, running direction and running frequency.

E2000 series inverter can realize 15-stage speed control and 8-stage speed auto circulating.

During the process of speed track, multi-stage speed control is invalid. After speed track is finished, inverter will run to target frequency according to the setting value of parameters.

|                       |                                                                                                 |                |
|-----------------------|-------------------------------------------------------------------------------------------------|----------------|
| F500 Stage speed type | Setting range: 0: 3-stage speed;<br>1: 15-stage speed;<br>2: Max 8-stage speed auto circulating | Mfr's value: 1 |
|-----------------------|-------------------------------------------------------------------------------------------------|----------------|

In case of multi-stage speed control (F203=4), the user must select a mode by F500. When F500=0, 3-stage speed is selected. When F500=1, 15-stage speed is selected. When F500=2, max 8-stage speed auto circulating is selected. When F500=2, "auto circulating" is classified into "2-stage speed auto circulating", "3-stage speed auto circulating", ... "8-stage speed auto circulating", which is to be set by F501.

**Table 6-7 Selection of Stage Speed Running Mode**

| F203 | F500                                                          | Mode of Running                    | Description                                                                                                                                                                                                         |
|------|---------------------------------------------------------------|------------------------------------|---------------------------------------------------------------------------------------------------------------------------------------------------------------------------------------------------------------------|
| 4    | 0                                                             | 3-stage speed control              | The priority in turn is stage-1 speed, stage-2 speed and stage-3 speed. It can be combined with analog speed control. If F207=4, "3-stage speed control" is prior to analog speed control.                          |
| 4    | 1                                                             | 15-stage speed control             | It can be combined with analog speed control. If F207=4, "15-stage speed control" is prior to analog speed control.                                                                                                 |
| 4    | 2                                                             | Max 8-stage speed auto circulating | Adjusting the running frequency manually is not allowable. "2-stage speed auto circulating", "3-stage speed auto circulating", ... "8-stage speed auto circulating" may be selected through setting the parameters. |
| F501 | Selection of Stage Speed Under Auto-circulation Speed Control |                                    | Setting range: 2~8<br>Mfr's value: 7                                                                                                                                                                                |
| F502 | Selection of Times of Auto-circulation Speed Control          |                                    | Setting range: 0~9999<br>(when the value is set to 0, the inverter will carry out infinite circulating)<br>Mfr's value: 0                                                                                           |
| F503 | Status After Auto-circulation Running Finished.               |                                    | Setting range:<br>0: Stop 1: Keep running at last-stage speed<br>Mfr's value: 0                                                                                                                                     |

· If running mode is auto-circulation speed control (F203=4 and F500=2), please set the related parameters by F501~F503.

· That the inverter runs at the preset stage speed one by one under the auto-circulation speed control is called as "one time".

- If F502=0, inverter will run at infinite auto circulation, which will be stopped by “stop” signal.
- If F502>0, inverter will run at auto circulation conditionally. When auto circulation of the preset times is finished continuously (set by F502), inverter will finish auto-circulation running conditionally. When inverter keeps running and the preset times is not finished, if inverter receives “stop command”, inverter will stop. If inverter receives “run command” again, inverter will automatically circulate by the setting time of F502.
- If F503=0, then inverter will stop after auto circulation is finished. If F503=1, then inverter will run at the speed of the last-stage after auto-circulation is finished as follows:  
e.g., F501=3, then inverter will run at auto circulation of 3-stage speed;  
F502=100, then inverter will run 100 times of auto circulation;  
F503=1, inverter will run at the speed of the last stage after the auto-circulation running is finished.

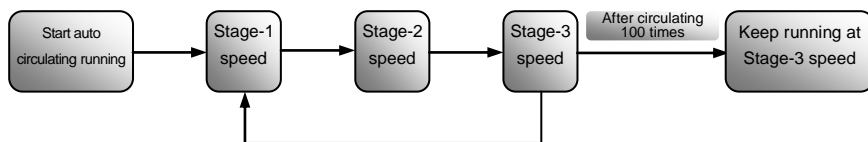

Figure 6-18 Auto-circulating Running

Then the inverter can be stopped by pressing “stop” or sending “stop” signal through terminal during auto-circulation running.

|           |                                                                       |                             |                                                             |                           |
|-----------|-----------------------------------------------------------------------|-----------------------------|-------------------------------------------------------------|---------------------------|
| F504      | Frequency setting for stage 1 speed (Hz)                              | Setting range:<br>F112~F111 | Mfr's value: 5.00                                           |                           |
| F505      | Frequency setting for stage 2 speed (Hz)                              |                             | Mfr's value: 10.00                                          |                           |
| F506      | Frequency setting for stage 3 speed (Hz)                              |                             | Mfr's value: 15.00                                          |                           |
| F507      | Frequency setting for stage 4 speed (Hz)                              |                             | Mfr's value: 20.00                                          |                           |
| F508      | Frequency setting for stage 5 speed (Hz)                              |                             | Mfr's value: 25.00                                          |                           |
| F509      | Frequency setting for stage 6 speed (Hz)                              |                             | Mfr's value: 30.00                                          |                           |
| F510      | Frequency setting for stage 7 speed (Hz)                              |                             | Mfr's value: 35.00                                          |                           |
| F511      | Frequency setting for stage 8 speed (Hz)                              |                             | Mfr's value: 40.00                                          |                           |
| F512      | Frequency setting for stage 9 speed (Hz)                              |                             | Mfr's value: 5.00                                           |                           |
| F513      | Frequency setting for stage 10 speed (Hz)                             |                             | Mfr's value: 10.00                                          |                           |
| F514      | Frequency setting for stage 11 speed (Hz)                             |                             | Mfr's value: 15.00                                          |                           |
| F515      | Frequency setting for stage 12 speed (Hz)                             |                             | Mfr's value: 20.00                                          |                           |
| F516      | Frequency setting for stage 13 speed (Hz)                             |                             | Mfr's value: 25.00                                          |                           |
| F517      | Frequency setting for stage 14 speed (Hz)                             |                             | Mfr's value: 30.00                                          |                           |
| F518      | Frequency setting for stage 15 speed (Hz)                             |                             | Mfr's value: 35.00                                          |                           |
| F519~F533 | Acceleration time setting for the speeds from Stage 1 to Stage 15 (S) |                             | Setting range:<br>0.1~3000                                  | Subject to inverter model |
| F534~F548 | Deceleration time setting for the speeds from Stage 1 to Stage 15 (S) |                             | Setting range:<br>0.1~3000                                  |                           |
| F549~F556 | Running directions of stage speeds from Stage 1 to Stage 8 (S)        |                             | Setting range:<br>0: forward running;<br>1: reverse running | Mfr's value: 0            |

|                                                                              |                                                                  |                  |
|------------------------------------------------------------------------------|------------------------------------------------------------------|------------------|
| F573~F579<br>Running directions of stage speeds from stage 9 to stage 15 (S) | Setting range:<br>0: forward running;<br>1: reverse running      | Mfr's value: 0   |
| F557~564 Running time of stage speeds from Stage 1 to Stage 8 (S)            | Setting range:<br>0.1~3000                                       | Mfr's value: 1.0 |
| F565~F572 Stop time after finishing stages from Stage 1 to Stage 8 (S)       | Setting range:<br>0.0~3000                                       | Mfr's value: 0.0 |
| F580 Stage-speed mode                                                        | Setting range:<br>0: Stage speed mode 1<br>1: Stage speed mode 2 | Mfr's value: 0   |

When F580=0, 0000 means invalid, 0001 means the first speed, 1111 means the 15<sup>th</sup> speed.

When F580=1, 0000 means the first speed, 0001 means the second speed, and so on. 1111 means invalid.

### 6.7 Auxiliary Functions

|                                               |                                                                                                                                        |                   |
|-----------------------------------------------|----------------------------------------------------------------------------------------------------------------------------------------|-------------------|
| F600 DC Braking Function Selection            | Setting range:<br>0: Invalid;<br>1: braking before starting;<br>2: braking during stopping;<br>3: braking during starting and stopping | Mfr's value: 0    |
| F601 Initial Frequency for DC Braking (Hz)    | Setting range: 0.20~50.00                                                                                                              | Mfr's value: 1.00 |
| F602 DC Braking efficiency before Starting    | Setting range:<br>0~250 for 30kW and below 30kW                                                                                        | Mfr's value: 50   |
| F603 DC Braking efficiency During Stop        | 0~200 for above 30kW                                                                                                                   | Mfr's value: 100  |
| F604 Braking Lasting Time Before Starting (S) | Setting range: 0.0~30.00                                                                                                               | Mfr's value: 0.50 |
| F605 Braking Lasting Time During Stopping (S) |                                                                                                                                        |                   |
| F656 Time of DC braking when stop             | Setting range: 0.00~30.00                                                                                                              | Mfr's value: 0    |

· When F600=0, DC braking function is invalid.

· When F600=1, braking before starting is valid. After the right starting signal is input, inverter starts DC braking. After braking is finished, inverter will run from the initial frequency.

In some application occasion, such as fan, motor is running at a low speed or in a reverse status, if inverter starts immediately, OC malfunction will occur. Adopting “braking before starting” will ensure that the fan stays in a static state before starting to avoid this malfunction.

During braking before starting, if “stop” signal is given, inverter will stop by deceleration time.

When F600=2, DC braking during stopping is selected. After output frequency is lower than the initial frequency for DC braking (F601), DC braking will stop the motor immediately

During the process of braking during stopping, if “start” signal is given, DC braking will be finished

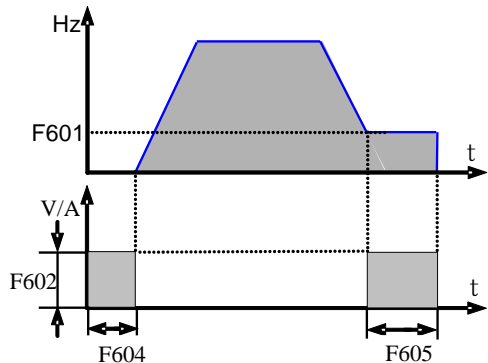

Figure 5-18 DC braking

and inverter will start.

If “stop” signal is given during the process of braking during stopping, inverter will have no response and DC braking during stopping still goes on.

· When jogging function is valid, the function of braking before starting set by F600 is valid, and the function of speed track is invalid.

· When jogging function is invalid and F613-1, the function of braking before starting is invalid.

· Parameters related to “DC Braking”: F601, F602, F603, F604, F605, interpreted as follows:

- F601: Initial frequency of DC-braking. DC braking will start to work as inverter’s output frequency is lower than this value.
- F602/F603: DC braking efficiency (the unit is the percentage of rated current). The bigger value will result in a quick braking. However, motor will overheat with too big value.
- F604: Braking duration before starting. The time lasted for DC braking before inverter starts.
- F605: Braking duration when stopping. The time lasted for DC braking while inverter stops.

Note: during DC braking, because motor does not have self-cold effect cause by rotating, it is in the state of easy over-heat. Please do not set DC braking voltage too high and do not set DC braking time to long.

DC braking, as shown in Figure 6-19

|      |                                          |                                                                                                          |                                       |
|------|------------------------------------------|----------------------------------------------------------------------------------------------------------|---------------------------------------|
| F607 | Selection of Stalling Adjusting Function | Setting range:<br>0~2:Reserved<br>3: Voltage/current control<br>4: Voltage control<br>5: Current control | Mfr’s value: 3                        |
| F608 | Stalling Current Adjusting (%)           | Setting range: 25~FC49                                                                                   | Mfr’s value: 160                      |
| F609 | Stalling Voltage Adjusting (%)           | Setting range: 110~200                                                                                   | Mfr’s value:<br>S2/T2: 130<br>T3: 140 |
| F610 | Stalling Protection Judging Time (S)     | Setting range: 0.0~3000                                                                                  | Mfr’s value: 60.0                     |

Initial value of stalling current adjusting is set by F608, when the present current is higher than rated current of inverter\*F608, stalling current adjusting function is valid.

During the process of acceleration, if output current is higher than initial value of stalling current adjusting, inverter will not accelerate until the output current is lower than initial value of stalling current adjusting.

In case of stalling during stable speed running, the frequency will drop.

F607 is used to set selection of stalling adjusting function.

Voltage control: when motor stops quickly or load changes suddenly, DC bus voltage will be high. Voltage control function can adjust deceleration time and output frequency to avoid OE.

When braking resistor or braking unit is used, please do not use voltage control function. Otherwise, the deceleration time will be changed.

Current control: when motor accelerates quickly or load changed suddenly, inverter may trip into OC. Current control function can adjust accel/decel time or decrease output frequency to control proper current value. It is only valid in VF control mode.

Note: (1) Voltage/current control is not suitable for lifting application.

(2) This function will change accel/decel time. Please use this function properly.

Initial value of stalling voltage adjusting is set by F609.

Stalling protection judging time is set by F610. When inverter starts stalling adjusting function and continues the setting time of F610, inverter will stop running and OL1 protection occurs.

|      |                                |                                                   |                           |
|------|--------------------------------|---------------------------------------------------|---------------------------|
| F611 | Dynamic Braking threshold      | Setting range:<br>T3: 600~2000<br>S2/T2: 320~2000 | Subject to inverter model |
| F612 | Dynamic braking duty ratio (%) | Setting range: 0~100                              | Mfr's value: 100          |

Initial voltage of dynamic braking threshold is set by F611. When DC bus voltage is higher than the setting value of this function, dynamic braking starts, braking unit starts working. After DC bus voltage is lower than the setting value, braking unit stops working.

The value of F611 should be set according to input voltage. When the input voltage is 400V, F611 should be set to 700V, when input voltage is 460V, F611 should be set to 770V. The lower the dynamic braking threshold is, the better dynamic braking effect is. But the heat of braking resistor is more serious. The higher the dynamic braking threshold is, the worse dynamic braking effect is. And at the process of braking, inverter will easily trip to OE.

Dynamic braking duty ratio is set by F612, the range is 0~100%. The value is higher, the braking effect is better, but the braking resistor will get hot.

|      |                           |                                                                |                  |
|------|---------------------------|----------------------------------------------------------------|------------------|
| F620 | Brake delay turn-off time | Setting range:<br>0.0 (brake not closed when stop)<br>0.1~3000 | Mfr's value: 5.0 |
|------|---------------------------|----------------------------------------------------------------|------------------|

F620=0, dynamic brake is not closed in stop status, it starts when PN voltage is higher than brake point; F620≠0, dynamic brake can proceed normally when inverter is running, the time set by F620 is the delay time after stop, then the dynamic brake closes automatically.

|      |             |                                                                  |                |
|------|-------------|------------------------------------------------------------------|----------------|
| F613 | Speed track | Setting range: 0: invalid 1: valid<br>2: valid at the first time | Mfr's value: 0 |
|------|-------------|------------------------------------------------------------------|----------------|

When F613=0, the function of speed track is invalid.

When F613=1, the function of speed track is valid.

After inverter tracks motor speed and rotating direction, inverter will start the rotating motor smoothly. This function is suitable for the situation of auto-starting after repowered on, auto-starting after reset, auto-starting when running command valid but direction signal lost and auto-starting when running command invalid.

When F613=2, the function is valid at the first time after inverter is repower on.

Note: When F106=0 or 6, speed track function is invalid.

|      |                  |                                                                                                                         |                |
|------|------------------|-------------------------------------------------------------------------------------------------------------------------|----------------|
| F614 | Speed track mode | Setting range:<br>0: Speed track from frequency memory<br>1: Speed track from zero<br>2: Speed track from max frequency | Mfr's value: 0 |
|------|------------------|-------------------------------------------------------------------------------------------------------------------------|----------------|

When F614 is set to 0, inverter will track speed down from frequency memory.

When F614 is set to 1, inverter will track speed up from 0Hz.

When F614 is set to 2, inverter will track speed down from max frequency.

|      |                  |                      |                 |
|------|------------------|----------------------|-----------------|
| F615 | Speed track rate | Setting range: 1~100 | Mfr's value: 20 |
|------|------------------|----------------------|-----------------|

It is used to select the rotation velocity speed track when the rotation tracking restart mode is adopted. The larger the parameter is, the faster the speed track is. But if this parameter is too large, it likely results in unreliable tracking.

|      |                               |                         |                  |
|------|-------------------------------|-------------------------|------------------|
| F618 | Delay time of speed track (S) | Setting range: 0.5~60.0 | Mfr's value: 1.5 |
|------|-------------------------------|-------------------------|------------------|



|                              |                                                                                                                                                                                            |                                |
|------------------------------|--------------------------------------------------------------------------------------------------------------------------------------------------------------------------------------------|--------------------------------|
| F638 Parameters copy enabled | Setting range:<br>0: Copy forbidden<br>1: Parameters download 1<br>(voltage level and power are totally same)<br>2: Parameters download 2<br>(without considering voltage level and power) | Mfr's value: 1                 |
| F639 Parameters copy code    | Setting range: 2000~2999                                                                                                                                                                   | Subject to version of software |
| F640 Parameter copy type     | Setting range:<br>0: Copy all parameters<br>1: Copy parameters (except motor parameters from F801 to F810/F844)                                                                            | Mfr's value: 1                 |

Please refer to the user manual of parameters copy.

The fault is as following:

| Code                               | Causes                                                                   |
|------------------------------------|--------------------------------------------------------------------------|
| Er71 Copy timeout                  | During copying process, there is no valid data during 3s.                |
| Er72 Copy when running             | Parameters copy when inverter is in the running status.                  |
| Er73 Copy without input password   | Password is valid and user does not input password.                      |
| Er74 Copy between different models | If copy code, or voltage level or power is different, copy is forbidden. |
| Er75 Copy forbidden                | Parameters copy when F638=0                                              |

|                                                         |                                    |                           |
|---------------------------------------------------------|------------------------------------|---------------------------|
| F641 Inhibition of current oscillation at low frequency | Setting range: 0~100<br>0: Invalid | Subject to inverter model |
|---------------------------------------------------------|------------------------------------|---------------------------|

When F641=0, inhibition function is invalid.

In the V/F control mode, if inhibition of current oscillation is valid, the following parameters are needed to be set.

- (1) F106=2 (V/F control mode) and F137≤2;
- (2) F613=0, the speed track function is invalid.

Note 1. When F641=1, one inverter can only drive one motor one time.

2. When F641=1, please set motor parameters (F801~F805, F844) correctly.
3. When inhibition oscillation function is invalid, and inverter runs without motor, output voltage may be unbalanced. This is normal situation. After inverter runs with motor, output voltage will be balanced.

|                           |                                                                                                                                  |                |
|---------------------------|----------------------------------------------------------------------------------------------------------------------------------|----------------|
| F643 Multi-functional key | Setting range:<br>0: Invalid<br>1: FWD jogging<br>2: REV jogging<br>3: Switchover between local/remote<br>4: Reverse run control | Mfr's value: 0 |
|---------------------------|----------------------------------------------------------------------------------------------------------------------------------|----------------|

This function is valid only for remote control keypad.

When F643=3, after pressing multi-functional key and switchover, F200 and F201 will be changed to 3 automatically, which is MODBUS. If user wants to switch to keypad, F200 and F201 should be set again.

When F643=4, after pressing multi-functional keypad, inverter runs reversely. (this function is only valid for LED remote keypad.)

Note: when F643=4, no matter what the value of F202 is, after pressing run key, inverter will run forward, and after pressing multi-functional key, inverter will run reversely.

|                          |                                                                                                                                                                                                                   |                |
|--------------------------|-------------------------------------------------------------------------------------------------------------------------------------------------------------------------------------------------------------------|----------------|
| F644 Keypad copy enabled | Setting range: 0: Invalid<br>1: current macro parameter upload<br>2: current macro parameter download<br>3: user macro 1 upload<br>4: user macro 1 download<br>5: user macro 2 upload<br>6: user macro 2 download | Mfr's value: 0 |
|--------------------------|-------------------------------------------------------------------------------------------------------------------------------------------------------------------------------------------------------------------|----------------|

·Keypad copy is only valid in LCD keypad.

In stop status, after saving user macro 1/2 parameters and setting F644=1, press “Run” key, inverter will enter parameter upload interface, all parameters of macro will be upload to keypad. When F644=3, user macro 1 parameters will be upload. When F644=5, user macro 2 parameters will be upload. After upload, when F644=2, parameters will be download to current user macro and cover the current parameters. When F644=4, parameters will be download to user macro1 and cover the parameters of macro 1. After setting F644=2, parameters will be download to user macro 2 and cover the parameters of macro 2.

|                                  |                |                                   |
|----------------------------------|----------------|-----------------------------------|
| F645 Status parameters selection | 0              | Running frequency                 |
|                                  | 1              | Rotation speed                    |
|                                  | 2              | Target speed                      |
|                                  | 3              | Output current                    |
|                                  | 4              | Output voltage                    |
|                                  | 5              | DC bus voltage                    |
|                                  | 6              | PID setting value                 |
|                                  | 7              | PID feedback value                |
|                                  | 8              | Radiator temperature              |
|                                  | 9              | Count value                       |
|                                  | 10             | Linear speed                      |
|                                  | 11             | Channel for main frequency        |
|                                  | 12             | Main frequency                    |
|                                  | 13             | Channel for accessorial frequency |
|                                  | 14             | Accessorial frequency             |
|                                  | 15             | Target frequency                  |
|                                  | 16             | Reserved                          |
|                                  | 17             | Output torque                     |
|                                  | 18             | Setting torque                    |
|                                  | 19             | Motor power                       |
|                                  | 20             | Output power                      |
| 21                               | Running status |                                   |

|  |    |                                  |
|--|----|----------------------------------|
|  | 22 | DI terminal status               |
|  | 23 | Output terminal status           |
|  | 24 | Stage speed of multi-stage speed |
|  | 25 | AI1 input value                  |
|  | 26 | AI2 input value                  |
|  | 28 | Reserved                         |
|  | 29 | Pulse input frequency            |
|  | 30 | Pulse output frequency           |
|  | 31 | AO1 output percent               |
|  | 32 | AO2 output percent               |
|  | 33 | Power on Hours                   |
|  | 34 | Length                           |
|  | 35 | Center frequency                 |

For four-line LCD, the displayed contents at first two lines can be changed by setting F645.

|                                |                                                       |                  |
|--------------------------------|-------------------------------------------------------|------------------|
| F646 Backlight time of LCD (S) | Setting range: 0~100                                  | Mfr's value: 100 |
| F647 Language selection        | Setting range: 0: Chinese<br>1: English<br>2: Deutsch | Mfr's value: 0   |

Change the duration of backlight by setting F646. F646=0, LCD light is always off; F646=100, LCD light is always on.

Change display language by setting F647, the default value is Chinese.

|                       |                                                                                            |                |
|-----------------------|--------------------------------------------------------------------------------------------|----------------|
| F649 Keypad selection | Setting range: 0: Automatic identification<br>1: LED remote keypad<br>2: LCD remote keypad | Mfr's value: 0 |
|-----------------------|--------------------------------------------------------------------------------------------|----------------|

When F649=0, inverter will identify the keypad automatically.

When F649=1, only LED keypad is valid.

When F649=2, only LCD keypad is valid.

Note: when F421=2(Local+ remote keypad is valid). If LCD remote keypad is valid, the local keypad does not display.

|                                            |                                                                                                              |                |
|--------------------------------------------|--------------------------------------------------------------------------------------------------------------|----------------|
| F657 Instantaneous power failure selection | Setting range:<br>0: Invalid<br>1: non-stop after power failure<br>2: decelerate to stop after power failure | Mfr's value: 0 |
|--------------------------------------------|--------------------------------------------------------------------------------------------------------------|----------------|

When F657=1, upon instantaneous power failure or sudden voltage dip, the function enables the inverter to compensate the DC bus voltage reduction with the load feedback energy by reducing the output frequency so as to keep the inverter running continuously.

When F657=2, upon instantaneous power failure or sudden voltage dip, the frequency will decrease rapidly and inverter will decelerate to stop.

Note: 1. F663 and F664 are related parameters, please increase them properly.

2: This function is not suitable for the application of heavy load and small inertial load.

|                                                                |                                       |                           |
|----------------------------------------------------------------|---------------------------------------|---------------------------|
| F658 Voltage rally acceleration time (S)                       | Setting range: 0.0~3000<br>0.0: F114  | Mfr's value: 0.0          |
| F659 Voltage rally deceleration time (S)                       | Setting range: 0.0~3000<br>0.0: F115  | Mfr's value: 0.0          |
| F660 Action judging voltage at instantaneous power failure (V) | Setting range:<br>200~F661            | Subject to inverter model |
| F661 Action stop voltage at instantaneous power failure (V)    | Setting range:<br>F660~1400           | Subject to inverter model |
| F662 Instantaneous voltage recovery judging time(s)            | Setting range: 0.00~10.00             | Mfr's value: 0.30         |
| F663 Instantaneous proportion coefficient Kp                   | Setting range: 0.00~10.00             | Mfr's value: 0.25         |
| F664 instantaneous integral coefficient Ki                     | Setting range: 0.00~10.00             | Mfr's value: 0.30         |
| F751 Instantaneous stop pretreatment enable                    | Setting range:<br>0: Invalid 1: Valid | Mfr's value: 0            |

Upon instantaneous power failure or sudden voltage dip, the DC bus voltage of the inverter reduces. The function enables the inverter to compensate the DC bus voltage reduction with the load feedback energy by reducing the output frequency so as to keep the inverter running continuously.

·The function is suitable for big inertia load, such as, fan and centrifugal pump.

The function is not suitable for the application which frequency is forbidden being decreased.

When the bus voltage resumes to normal, F658/F659 are used to set the accel/dec time when inverter runs to target frequency.

·When instantaneous function is valid, if PN voltage is lower than F660, instantaneous function works.

·When inverter is at instantaneous status, if PN voltage is higher than F661, the bus voltage remains to normal, inverter will work normally and run to target frequency.

|                                                         |                           |                   |
|---------------------------------------------------------|---------------------------|-------------------|
| F670 Voltage-limit current-limit adjustment coefficient | Setting range: 0.01~10.00 | Mfr's value: 2.00 |
|---------------------------------------------------------|---------------------------|-------------------|

Lower this factor properly if frequent over-voltage protection occurs in the process of deceleration; Increase the factor when deceleration is too slow.

|                                                 |                                                                                                                         |                    |
|-------------------------------------------------|-------------------------------------------------------------------------------------------------------------------------|--------------------|
| F671 voltage source for V/F separation          | Setting range:<br>0: F672 1: AI1 2: AI2 3: AI3<br>4: Communication setting<br>5: pulse setting 6: PID<br>7~10: reserved | Mfr's value: 0     |
| F672 Voltage digital setting for V/F separation | Setting range: 0.00~100.00                                                                                              | Mfr's value: 100.0 |

F671 is 100% of the setting corresponds to the rated motor voltage.

· 0: digital setting, the output voltage is set by F672.

· 1: AI1; 2: AI2; 3: AI3;

The output voltage is set by analog.

· 4: Communication setting

The output voltage is set by PC/PLC, the communication address is 2009H, the given range is 0~10000, which means 0~100% of rated voltage.

· 5 pulse setting

The output voltage is set by external high-speed pulse. The input frequency of pulse corresponds to motor

rated voltage.

· 6: PID

The output voltage is set by PID. PID adjustment corresponds to 100% of motor rated voltage. For details, please refer to PID parameters group.

|                                                   |                            |                     |
|---------------------------------------------------|----------------------------|---------------------|
| F673 Lower limit of voltage at V/F separation (%) | Setting range: 0.00~F674   | Mfr's value: 0.00   |
| F674 Upper limit of voltage at V/F separation (%) | Setting range: F673~100.00 | Mfr's value: 100.00 |

When the voltage is lower than F673, the voltage should equal to F673. When the voltage is higher than F674, the voltage should equal to F674.

|                                                 |                           |                  |
|-------------------------------------------------|---------------------------|------------------|
| F675 Voltage rise time of V/F separation (S)    | Setting range: 0.0~3000.0 | Mfr's value: 5.0 |
| F676 Voltage decline time of V/F separation (S) | Setting range: 0.0~3000.0 | Mfr's value: 5.0 |

F675 is the time required for the output voltage to rise from 0V to the rated motor voltage.

F676 is the time required for the output voltage to decline from the rated motor voltage to 0V.

|                                  |                                                                                                                                                               |                |
|----------------------------------|---------------------------------------------------------------------------------------------------------------------------------------------------------------|----------------|
| F677 Stop mode at V/F separation | Setting range:<br>0: voltage and frequency declines to 0 according to respective time.<br>1: Voltage declines to 0 first<br>2: frequency declines to 0 first. | Mfr's value: 0 |
|----------------------------------|---------------------------------------------------------------------------------------------------------------------------------------------------------------|----------------|

When F677 = 0, voltage and frequency declines to 0 according to respective time, inverter will stop when frequency declines to 0.

When F677 = 1, voltage will decline to 0 at first. After voltage is 0, frequency will decline to 0.

When F677 = 2, frequency will decline to 0 at first. After frequency is 0, voltage will decline to 0.

|                                                 |                                               |                  |
|-------------------------------------------------|-----------------------------------------------|------------------|
| F678 Judgment voltage at V/F separation         | Setting range: 0: invalid<br>1: auto judgment | Mfr's value: 0   |
| F679 Voltage switch point at V/F separation (V) | Setting range: 200~600                        | Mfr's value: 430 |
| F680 Switch point width at V/F separation (%)   | Setting range: 0.0~100.0                      | Mfr's value: 0.5 |

When F678=0, judgment voltage is invalid.

When F678=1, input voltage is judged automatically. When input voltage is higher than  $(F679 + F679 * F680)$ , the current input voltage is judged to T3 380V. If input voltage is lower than  $(F679 + F679 * F680)$ , the current input voltage is judged to S2 220V.

## 6.8. Malfunction and Protection

|                                                                |                                                                     |                  |
|----------------------------------------------------------------|---------------------------------------------------------------------|------------------|
| F700 Selection of terminal free stop mode                      | Setting range:<br>0: free stop immediately;<br>1: delayed free stop | Mfr's value: 0   |
| F701 Delay time for free stop and programmable terminal action | Setting range: 0.0~60.0S                                            | Mfr's value: 0.0 |

· “Selection of free stop mode” can be used only for the mode of “free stop” controlled by the terminal. The related parameters setting is F201=1, 2, 4.

When “free stop immediately” is selected, delay time (F701) will be invalid and inverter will free stop immediately.

· “Delayed free stop” means that upon receiving “free stop” signal, the inverter will execute “free stop” command after waiting some time instead of stopping immediately. Delay time is set by F701. During the process of speed track, the function of delayed free stop is invalid.

|                       |                                                                                                            |                |
|-----------------------|------------------------------------------------------------------------------------------------------------|----------------|
| F702 Fan control mode | 0: controlled by temperature<br>1: Running when inverter is powered on.<br>2: controlled by running status | Mfr's value: 2 |
|-----------------------|------------------------------------------------------------------------------------------------------------|----------------|

When F702=0, fan will run if radiator's temperature is up to setting temperature 35℃.

When F702=2, fan will run when inverter begins running. When inverter stops, fan will stop until radiator's temperature is lower than 40℃.

|                                                     |                        |                  |
|-----------------------------------------------------|------------------------|------------------|
| F704 Inverter Overloading pre-alarm Coefficient (%) | Setting range: 50~100  | Mfr's value: 80  |
| F705 Motor Overloading pre-alarm Coefficient (%)    | Setting range: 50~100  | Mfr's value: 80  |
| F706 Inverter Overloading Coefficient (%)           | Setting range: 120~190 | Mfr's value: 150 |
| F707 Motor Overloading Coefficient (%)              | Setting range: 20~100  | Mfr's value: 100 |

When inverter or motor is in over current status, if the accumulation time is more than inverter's or motor's overload protection time \* F704 or F705, and F300 or F301 or F302=10 or 11, inverter will output ON signal.

Inverter overloading coefficient: the ratio of overload-protection current and rated current, whose value shall be subject to actual load.

· Motor overloading coefficient (F707): when inverter drives lower power motor, please set the value of F707 by below formula in order to protect motor

$$\text{Motor Overloading Coefficient} = \frac{\text{Actual motor power}}{\text{Matching motor power}} \times 100\%$$

Please set F707 according to actual situation. The lower the setting value of F707 is, the faster the overload protection speed. Please refer to Fig 6-20.

For example: 7.5kW inverter drives 5.5kW motor,  $F707 = \frac{5.5}{7.5} \times 100\% \approx 70\%$ . When the actual

current of motor reaches 140% of inverter rated current, inverter overload protection will display after 1 minute.

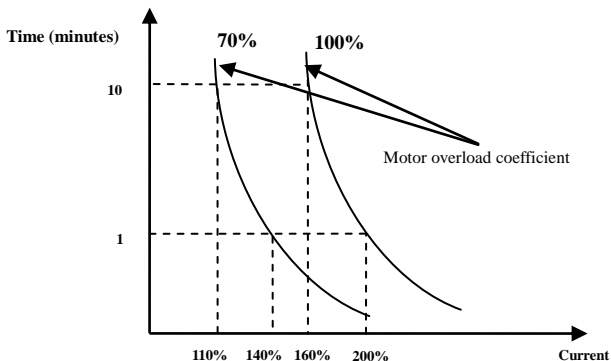

Fig 6-20 Motor overload coefficient

When the output frequency is lower than 10Hz, the heat dissipation effect of common motor will be worse. So when running frequency is lower than 10Hz, the threshold of motor overload value will be reduced. Please refer to Fig 6-21 (F707=100%):

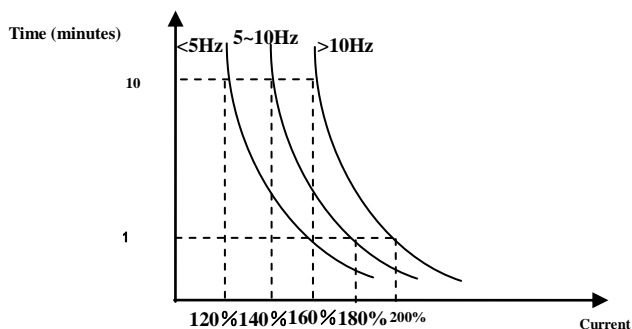

Fig 6-21 Motor overload protection value

|      |                                                 |                                               |  |
|------|-------------------------------------------------|-----------------------------------------------|--|
| F708 | Record of The Latest Malfunction Type           | Setting range:<br>Please refer to Appendix 1. |  |
| F709 | Record of Malfunction Type for Last but One     |                                               |  |
| F710 | Record of Malfunction Type for Last but Two     |                                               |  |
| F711 | Fault Frequency of The Latest Malfunction (Hz)  |                                               |  |
| F712 | Fault Current of The Latest Malfunction (A)     |                                               |  |
| F713 | Fault PN Voltage of The Latest Malfunction (V)  |                                               |  |
| F714 | Fault Frequency of Last Malfunction but One(Hz) |                                               |  |

|      |                                                  |                                                               |                                |
|------|--------------------------------------------------|---------------------------------------------------------------|--------------------------------|
| F715 | Fault Current of Last Malfunction but One(A)     |                                                               |                                |
| F716 | Fault PN Voltage of Last Malfunction but One (V) |                                                               |                                |
| F717 | Fault Frequency of Last Malfunction but Two(Hz)  |                                                               |                                |
| F718 | Fault Current of Last Malfunction but Two (A)    |                                                               |                                |
| F719 | Fault PN Voltage of Last Malfunction but Two (V) |                                                               |                                |
| F720 | Record of overcurrent protection fault times     |                                                               |                                |
| F721 | Record of overvoltage protection fault times     |                                                               |                                |
| F722 | Record of overheat protection fault times        |                                                               |                                |
| F723 | Record of overload protection fault times        |                                                               |                                |
| F724 | Input phase loss                                 | Setting range:<br>0: invalid; 1: valid                        | Mfr's value:<br>S2: 0 T2/T3: 1 |
| F725 | Under-voltage protection                         | Setting range:<br>0: reset manually<br>1: reset automatically | Mfr's value: 2                 |
| F726 | Overheat                                         | Setting range:<br>0: invalid; 1: valid                        | Mfr's value: 1                 |
| F727 | Output phase loss                                | Setting range:<br>0: invalid; 1: valid                        | Mfr's value: 1                 |
| F728 | Input phase loss filtering constant (S)          | Setting range: 1~60                                           | Mfr's value: 5                 |
| F729 | Under-voltage filtering constant (2mS)           | Setting range: 1~3000                                         | Mfr's value: 5                 |
| F730 | Overheat protection filtering constant (S)       | Setting range: 0.1~60.0                                       | Mfr's value: 5.0               |
| F732 | Under-voltage protection voltage threshold (V)   | Setting range: T2/S2: 120~450<br>T3: 300~450                  | Subject to inverter model      |

“Input phase loss” refers to phase loss of three-phase power supply, 5.5kW and below 5.5kW do not have this function.

“Output phase loss” refers to phase loss of inverter three-phase wirings or motor wirings.

“Under-voltage” / “phase loss” signal filtering constant is used for the purpose of eliminating disturbance to avoid mis-protection. The greater the set value is, the longer the filtering time constant is and the better for the filtering effect.

|      |                                       |                                   |                  |
|------|---------------------------------------|-----------------------------------|------------------|
| F737 | Over-current 1 protection             | Setting range: 0:Invalid 1: Valid | Mfr's value: 1   |
| F738 | Over-current 1 protection coefficient | Setting range: 0.50~3.00          | Mfr's value: 2.5 |
| F739 | Over-current 1 protection record      |                                   |                  |

·F738= OC 1 value/inverter rated current

·In running status, F738 is not allowed to modify. When over-current occurs, OC1 is displayed

|      |                                                 |                                                                                                                                                            |                 |
|------|-------------------------------------------------|------------------------------------------------------------------------------------------------------------------------------------------------------------|-----------------|
| F741 | Analog disconnected protection                  | Setting range:<br>0: Invalid<br>1: Stop and AErr displays.<br>2: Stop and Aerr is not displayed.<br>3: Inverter runs at the min frequency.<br>4: Reserved. | Mfr's value: 0  |
| F742 | Threshold of analog disconnected protection (%) | Setting range: 1~100                                                                                                                                       | Mfr's value: 50 |



When the values of F400 and F406 are lower than 0.10V, analog disconnected protection is invalid. Analog channel AI3 has no disconnected protection.

When F741 is set to 1, 2 or 3, the values of F400 and F406 should be set to 1V-2V, to avoid the error protection by interference.

Analog disconnected protection voltage=analog channel input lower limit \* F742. Take the AI1 channel for the example, if F400=1.00, F742=50, then disconnection protection will occur when the AI1 channel voltage is lower than 0.5V.

|                                         |                         |                  |
|-----------------------------------------|-------------------------|------------------|
| F743 Filtering constant of checking STO | Setting range: 0.1~10.0 | Mfr's value: 0.5 |
|-----------------------------------------|-------------------------|------------------|

It is used to eliminate interference to avoid mis-protection. The bigger the setting filtering constant is, the better filtering effect is.

|                                                 |                                    |                 |
|-------------------------------------------------|------------------------------------|-----------------|
| F745 Threshold of pre-alarm overheat (%)        | Setting range: 0~100               | Mfr's value: 80 |
| F746 Carrier frequency auto-adjusting threshold | Setting range: 60~100              | Mfr's value: 75 |
| F747 Carrier frequency auto-adjusting           | Setting range: 0: Invalid 1: Valid | Mfr's value: 1  |

When the temperature of radiator reaches the value of 90°C \* F745 and multi-function output terminal is set to 16 (Please refer to F300~F302), it indicates inverter is in the status of overheat.

When temperature is higher than setting temperature, F746 is used to reduce carrier frequency.

When F747=1, the temperature of radiator reaches to certain temperature, inverter carrier frequency will adjust automatically, to decrease the temperature of inverter. This function can avoid overheat malfunction.

When F159=1, random carrier frequency is selected, F747 is invalid.

When F106=6, F747 is invalid all the time.

|                                       |                                                                  |                  |
|---------------------------------------|------------------------------------------------------------------|------------------|
| F752 Overload quitting coefficient    | Setting range: 0.1~20.0                                          | Mfr's value: 1.0 |
| F753 Selection of overload protection | Setting range:<br>0: Normal motor<br>1: variable frequency motor | Mfr's value: 1   |

The bigger the setting value of F752 is, the faster the shortened overload cumulative time is.

When F753=0, because heat dissipation effect of normal motor is bad in low speed, the electronic thermal protection value will be adjusted properly. It means overload protection threshold of motor will be decreased when running frequency is lower than 30Hz.

When F753=1, because heat dissipation effect of variable frequency motor is not influenced by speed, there is no need to adjust the protection value.

|                                        |                       |                  |
|----------------------------------------|-----------------------|------------------|
| F754 Zero-current threshold (%)        | Setting range: 0~200  | Mfr's value: 5   |
| F755 Duration time of zero-current (S) | Setting range: 0~60.0 | Mfr's value: 0.5 |

When the output current is fallen to zero-current threshold, and after the duration time of zero-current, ON signal is output.

|                                      |                                  |                  |
|--------------------------------------|----------------------------------|------------------|
| F756 Delay time when drive runs (ms) | Setting range: 0: Invalid 1~5000 | Mfr's value: 0   |
| F757 Delay time when drive stops (S) | Setting range: 0.0~100.0         | Mfr's value: 5.0 |

When F756=0, bus voltage base is not detected when voltage limiting.

When F756 ≠ 0, after SD close, bus voltage will be detected recurrently after setting delay time.

After the drive stops, bus voltage will be detected recurrently after setting delay time. The detected value is saved in H016.

|                              |                     |                |
|------------------------------|---------------------|----------------|
| F759 Carrier-frequency ratio | Setting range: 3~15 | Mfr's value: 7 |
|------------------------------|---------------------|----------------|

carrier frequency=running frequency \*F759. When the product of running frequency and F759 is higher than carrier frequency, actual carrier frequency will be increased automatically, and it will not be limited by temperature control carrier frequency.

|      |                      |                                    |                |
|------|----------------------|------------------------------------|----------------|
| F760 | Grounding protection | Setting range: 0: Invalid 1: Valid | Mfr's value: 0 |
|------|----------------------|------------------------------------|----------------|

When output terminals (U, V, W) are connected to the earth or the earth impedance is too low, then the leak current is high, inverter will trip into GP. When grounding protection is valid, U, V, W will output voltage for a while after power on.

Note: S2 series and below 3.0kw inverters do not have GP protection.

|      |                            |                                                    |                |
|------|----------------------------|----------------------------------------------------|----------------|
| F761 | Switchover mode of FWD/REV | Setting range: 0: At zero<br>2: at start frequency | Mfr's value: 0 |
|------|----------------------------|----------------------------------------------------|----------------|

When F761 = 0, FWD/REV switches at zero frequency, F120 is valid.

When F761 = 1, FWD/REV switches at start frequency, F120 is invalid, if start frequency is too high, current shock will occur during switchover process.

|      |                       |  |  |
|------|-----------------------|--|--|
| F770 | Auxiliary version No. |  |  |
|------|-----------------------|--|--|

It only can be checked.

## 6.9. Parameters of the Motor

|      |                              |                                                                              |                |
|------|------------------------------|------------------------------------------------------------------------------|----------------|
| F800 | Motor's parameters tuning    | Setting range:<br>0: Invalid;<br>1: Rotating tuning;<br>2: stationary tuning | Mfr's value: 0 |
| F801 | Rated power (kW)             | Setting range: 0.1~1000.0                                                    |                |
| F802 | Rated voltage (V)            | Setting range: 1~1300                                                        |                |
| F803 | Rated current (A)            | Setting range: 0.2~6553.5                                                    |                |
| F804 | Number of motor poles        | Setting range: 2~100                                                         | 4              |
| F805 | Rated rotary speed (rpm/min) | Setting range: 1~39000                                                       |                |
| F810 | Motor rated frequency (Hz)   | Setting range: 1.00~650.00                                                   | 50.00          |

**Please set the parameters in accordance with those indicated on the nameplate of the motor.**

**Excellent control performance of vector control requires accurate parameters of the motor. Accurate parameter tuning requires correct setting of rated parameters of the motor.**

**In order to get the excellent control performance, please configure the motor in accordance with adaptable motor of the inverter. In case of too large difference between the actual power of the motor and that of adaptable motor for inverter, the inverter's control performance will decrease remarkably.**

F800=0, parameter tuning is invalid. But it is still necessary to set the parameters F801~F803, F805 and F810 correctly according to those indicated on the nameplate of the motor.

After being powered on, it will use default parameters of the motor (see the values of F806-F809) according to the motor power set in F801. This value is only a reference value in view of Y series 4-pole asynchronous motor. For PMSM, please input motor parameters to F870~F873 manually.

F800=1, rotating tuning.

In order to ensure dynamic control performance of the inverter, select "rotating tuning" after ensuring that the motor is disconnected from the load. Please set F801-805 and F810 correctly prior to running testing. If control mode is closed-loop vector control, please set F851 correctly.

Operation process of rotating tuning: Press the "Run" key on the LED keypad to display "TEST", press "Run" key on the LCD keypad to display "parameter measurement...." and it will tune the motor's

parameter of two stages. After that, the motor will accelerate according to acceleration time set at F114 and maintain it for a certain period. The motor will then decelerate to 0 according to the time set at F115. After auto-checking is completed, relevant parameters of the IM motor will be stored in function codes F806~F809. And relevant parameters of PMSM will be stored in F870~F873. F800 will turn to 0 automatically

F800=2, stationary tuning.

It is suitable for the cases where it is impossible to disconnect the motor from the load.

Press the “Run” key, and the inverter will display “TEST”, and it will tune the motor’s parameter of two stages. The motor’s stator resistance, rotor resistance and leakage inductance will be stored in F806-F809 automatically (the motor’s mutual inductance uses default value generated according to the power). For PMSM, electric parameters are stored to F870~F873. F870 is theory value, user can ask the accurate back electromotive force from manufacture. And F800 will turn to 0 automatically. The user may also calculate and input the motor’s mutual inductance value manually according to actual conditions of the motor. With regard to calculation formula and method, please call us for consultation.

When tuning the motor’s parameter, motor is not running but it is powered on. Please do not touch motor during this process.

**\*Note:**

1. No matter which tuning method of motor parameter is adopted, please set the information of the motor (F801-F805) correctly according to the nameplate of the motor. If the operator is quite familiar with the motor, the operator may input all the parameters (F806-F809) of the motor manually.
2. Parameter F804 can only be checked, not be modified.
3. Incorrect parameters of the motor may result in unstable running of the motor or even failure of normal running. Correct tuning of the parameters is a fundamental guarantee of vector control performance. Each time when F801 rated power of the motor is changed, the parameters of the motor (F806-F809) will be refreshed to default settings automatically. Therefore, please be careful while amending this parameter. The motor’s parameters may change when the motor heats up after running for a long time. If the load can be disconnected, we recommend auto-checking before each running.

|      |                           |                                                                                            |                              |
|------|---------------------------|--------------------------------------------------------------------------------------------|------------------------------|
| F806 | Stator resistance (Ω)     | Setting range:<br>0.001~65.53Ω (for 15kw and below 15kw)<br>0.1~6553mΩ (For above 15kw)    | Subject to<br>inverter model |
| F807 | Rotor resistance (Ω)      | Setting range:<br>0.001~65.53Ω (for 152kw and below 15kw)<br>0.1~6553mΩ (For above 15kw)   |                              |
| F808 | Leakage inductance (mH)   | Setting range:<br>0.01~655.3mH (for 15kw and below 15kw)<br>0.001~65.53mH (for above 15kw) |                              |
| F809 | Mutual inductance (mH)    | Setting range:<br>0.1~6553mH (for 15kw and below 15kw)<br>0.01~655.3mH (for above 15 kw)   |                              |
| F844 | Motor no-load current (A) | Setting range: 0.1~F803                                                                    |                              |

The set values of F806~F809 will be updated automatically after normal completion of parameter tuning of the motor.

If it is impossible to measure the motor at the site, input the parameters manually by referring to the known parameters of a similar motor.

F844 can be got automatically by rotating tuning.

If the no-load current is higher when motor is running, please decrease the value of F844.

If running current or start current is higher when motor is running with load, please increase the value of F844.

Take a 3.7kW inverter for the example: all data are 3.7kW, 400V, 8.8A, 1440rpm, 50Hz, and the load is disconnected. When F800=1, the operation steps are as following:

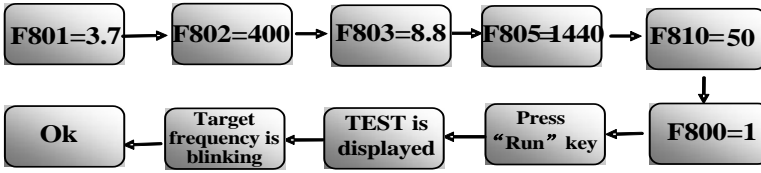

|                                              |                           |                   |
|----------------------------------------------|---------------------------|-------------------|
| F811 Carrier frequency switchover point (Hz) | Setting range: 0.00~20.00 | Mfr's value: 8.00 |
|----------------------------------------------|---------------------------|-------------------|

When F811 = 0, there is no carrier frequency switchover.

When F811≠0, and frequency is lower than switchover point, carrier frequency is internal fixed carrier-frequency. When running frequency is higher than switchover point, carrier frequency will switch to setting carrier frequency.

|      |                           |                           |                           |
|------|---------------------------|---------------------------|---------------------------|
| F812 | Pre-exciting time (S)     | Setting range: 0.00~30.00 | 0.10                      |
| F813 | Rotary speed loop KP1     | Setting range: 1~100      | 30                        |
| F814 | Rotary speed loop KI1     | Setting range: 0.01~10.00 | 0.50                      |
| F815 | Rotary speed loop KP2     | Setting range:1~100       | Subject to inverter model |
| F816 | Rotary speed loop KI2     | Setting range:0.01~10.00  | 1.00                      |
| F817 | PID switching frequency 1 | Setting range: 0~F818     | 5.00                      |
| F818 | PID switching frequency 2 | Setting range: F817~F111  | 10.00                     |

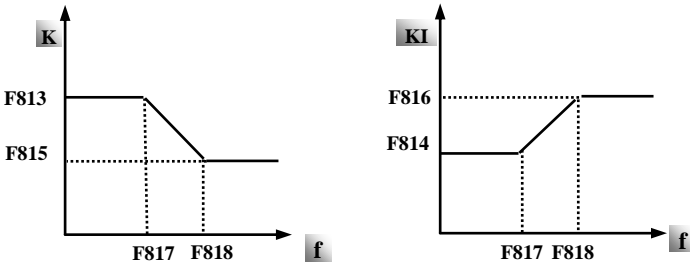

Fig 6-22 PID parameter

Dynamic response of vector control speed can be adjusted through adjusting proportional and storage gains of speed loop. Increasing KP and decreasing KI can speed up dynamic response of speed loop. However, if proportional gain or storage gain is too large, it may give rise to oscillation.

Recommended adjusting procedures:

Make fine adjustment of the value on the basis of manufacturer value if the manufacturer setting value cannot meet the needs of practical application. Be cautious that amplitude of adjustment each time should not be too large.

In the event of weak loading capacity or slow rising of rotary speed, please decrease the value of KP first under the precondition of ensuring no oscillation. If it is stable, please increase the value of KI properly to speed up response.

In the event of oscillation of current or rotary speed, decrease KP and increase KI properly.

Note: Improper setting of KP and KI may result in violent oscillation of the system, or even failure of normal operation. Please set them carefully.

|                                          |                       |                  |
|------------------------------------------|-----------------------|------------------|
| F819 Slip coefficient                    | Setting range: 50~200 | Mfr's value: 100 |
| F820 Filtering coefficient of speed loop | Setting range: 0~100  | Mfr's value: 0   |

F819 is used to adjust steady speed precision of motor in vector control.

In vector control mode, if speed fluctuation is higher or inverter stops instability, please increase the value of F820 properly; it will influence response speed of speed loop.

|                                          |                         |                  |
|------------------------------------------|-------------------------|------------------|
| F822 Upper limit of speed control torque | Setting range:0.0~250.0 | Mfr's value: 200 |
|------------------------------------------|-------------------------|------------------|

The parameter of F822 limits the output current in the vector control mode.

|                       |                                                       |                |
|-----------------------|-------------------------------------------------------|----------------|
| F838 SVC control mode | Setting range:<br>1: control mode 1 2: control mode 2 | Mfr's value: 2 |
|-----------------------|-------------------------------------------------------|----------------|

|                                          |                                                             |                |
|------------------------------------------|-------------------------------------------------------------|----------------|
| F840 Stop after detecting feedback value | Setting range:<br>0: By feedback speed<br>1: By given speed | Mfr's value: 0 |
|------------------------------------------|-------------------------------------------------------------|----------------|

F840=0, in deceleration process, inverter will stop until feedback speed meets the needs of stop command.

F840=1, in deceleration process, inverter will stop until given speed meets the needs of stop command.

|                                              |                         |                  |
|----------------------------------------------|-------------------------|------------------|
| F847 Encoder disconnection detection time(s) | Setting range: 0.1~10.0 | Mfr's value: 2.0 |
|----------------------------------------------|-------------------------|------------------|

This parameter is only valid in encoder vector control mode. Using F847 to define the encoder signal disconnection detection time under the closed-loop vector control mode when F106=1. PG protection is given if detection time exceeds the setting value.

|                                                   |                      |                 |
|---------------------------------------------------|----------------------|-----------------|
| F850 Detection threshold of encoder disconnection | Setting range: 5~100 | Mfr's value: 30 |
|---------------------------------------------------|----------------------|-----------------|

In the closed-loop vector control mode, when the difference between encoder setting frequency and actual frequency is higher than F850, and duration time is longer than F847, inverter will trip into PG.

|                         |                       |                   |
|-------------------------|-----------------------|-------------------|
| F851 Encoder resolution | Setting range: 1~9999 | Mfr's value: 1000 |
|-------------------------|-----------------------|-------------------|

Note: when F106=1, PG card must be installed, and set encoder resolution correctly

|                             |                                                             |                |
|-----------------------------|-------------------------------------------------------------|----------------|
| F854 Encoder phase sequence | Setting range: 0: forward direction<br>1: reverse direction | Mfr's value: 0 |
|-----------------------------|-------------------------------------------------------------|----------------|

F854 is used to set phase sequence of differential and non-differential ABZ incremental encoder. In closed-loop vector mode, correct encoder phase sequence can be got by rotating tuning.

If motor parameters cannot be studied by rotating tuning, please set F854 by checking H015 value.

For example, inverter runs more than 5s in V/F control mode, after inverter stops, then check the value of H015. If H015=0, please do not change the value of F854. If H015=1, then change the value of F854.

|                                        |                                    |                    |
|----------------------------------------|------------------------------------|--------------------|
| F866 Static position identification    | Setting range: 0: Invalid 1: Valid | Mfr's value: 0     |
| F867 Position identification current   | Setting range: 0~30                | Mfr's value: 10    |
| F868 Position identification frequency | Setting range: 2000~16000          | Mfr's value: 10000 |

F868: during position identification process, F868 is the frequency of output high-frequency voltage.

Note: F866~F868 is only for synchronous motor.

|      |                                                |                                                          |                    |
|------|------------------------------------------------|----------------------------------------------------------|--------------------|
| F870 | PMSM back electromotive force (mV/rpm)         | Setting range: 0.1~6553.0<br>(valid value between lines) | Mfr's value: 100.0 |
| F871 | PMSM D-axis inductance (mH)                    | Setting range: 0.01~655.30                               | Mfr's value:5.00   |
| F872 | PMSM Q-axis inductance (mH)                    | Setting range: 0.01~655.30                               | Mfr's value:7.00   |
| F873 | PMSM stator resistance (Ω)<br>(phase resistor) | Setting range: 0.001~65.530                              | Mfr's value:0.500  |

\* F870(back electromotive force of PMSM, unit = 0.1mV/1rpm, it is back electromotive force value between lines), it is forbidden to revert to Mfr's value by F160.

\* F871(PMSM D-axis inductance, unit = 0.01 mH), it is forbidden to revert to Mfr's value by F160.

\* F872(PMSM Q-axis inductance, unit = 0.01 mH), it is forbidden to revert to Mfr's value by F160.

\* F873(PMSM Stator resistance, unit = m-ohm, 0.001 ohm), it is forbidden to revert to Mfr's value by F160.

\* F870-F873 are motor parameters of PMSM, they are not shown in the motor nameplate. User can get them by auto tuning or asking manufacture.

|                                                                            |                          |                   |
|----------------------------------------------------------------------------|--------------------------|-------------------|
| F876 PMSM injection current without load (%)                               | Setting range: 0.0~100.0 | Mfr's value: 20.0 |
| F877 PMSM injection current compensation without load (%)                  | Setting range: 0.0~50.0  | Mfr's value: 0.0  |
| F878 PMSM cut-off point of injection current compensation without load (%) | Setting range: 0.0~50.0  | Mfr's value: 10.0 |
| F879 PMSM injection current with heavy load (%)                            | Setting range: 0.0~100.0 | Mfr's value: 0.0  |

F876, F877 and F879 are the percent of rated current. F878 is the percent of rated frequency.

For example:

When F876=20, if F877=10 and F878=0, the injection current without load is 20% of rated current.

When F876=20, if F877=10 and F878=10, and rated frequency is 50Hz, injection current without load will decrease by a linear trend from 30 (F876+F877). When inverter runs to 5Hz (5Hz=rated frequency X F878%), injection current will decrease to 20, and 5Hz is cut-off point of injection current compensation without load.

|      |                             |                         |                  |
|------|-----------------------------|-------------------------|------------------|
| F880 | PMSM PCE detection time (S) | Setting range: 0.0~10.0 | Mfr's value: 0.2 |
|------|-----------------------------|-------------------------|------------------|

## 6.10. Communication Parameter

|                            |                                                                                     |                |
|----------------------------|-------------------------------------------------------------------------------------|----------------|
| F900 Communication Address | Setting range:<br>1~255: single inverter address<br>0: broadcast address            | Mfr's value: 1 |
| F901 Communication Mode    | Setting range: 1: ASCII 2: RTU<br>3: Remote keypad                                  | Mfr's value: 2 |
| F902 Stop bits             | Setting range: 1~2                                                                  | Mfr's value: 2 |
| F903 Parity Check          | Setting range:<br>0: Invalid 1: Odd 2: Even                                         | Mfr's value: 0 |
| F904 Baud Rate             | Setting range:<br>0: 1200; 1: 2400; 2: 4800;<br>3: 9600; 4: 19200 5: 38400 6: 57600 | Mfr's value: 3 |

|                                          |                           |                  |
|------------------------------------------|---------------------------|------------------|
| F905 Communication timeout period (S)    | Setting range: 0.0~3000.0 | Mfr's value: 0.0 |
| F907 Time 2 of communication timeout (S) | Setting range: 0.0~3000.0 | Mfr's value: 0.0 |

F904=9600 is recommended for baud rate, which makes run steady. Communication parameters refer to Appendix 4.

When F905 is set to 0.0, the function is invalid. When  $F905 \neq 0.0$ , if the inverter has not received effective command from PC/PLC during the time set by F905, inverter will trip into CE.

When  $F907 > 0$ , and receiving the previous data, if after the time set by F907, the next data is not received, inverter will output communication timeout signal. The timeout signal will be cleared by this terminal, and after receiving correct data, inverter will accumulate time again.

|                                          |                                        |                |
|------------------------------------------|----------------------------------------|----------------|
| F911 Point-point communication selection | Setting range:<br>0:Disabled 1:Enabled | Mfr's value:0  |
| F912 Master and slave selection          | Setting range:<br>0:Master 1:Slave     | Mfr's value: 0 |

F911 is sued to decide whether to enable point-point communication.

F912 is used to decide whether inverter is master or slave.

|                               |                                                                                                                    |                |
|-------------------------------|--------------------------------------------------------------------------------------------------------------------|----------------|
| F913 Running command of slave | Setting range:<br>0:Slave not following running commands of master<br>1:Slave following running commands of master | Mfr's value: 1 |
|-------------------------------|--------------------------------------------------------------------------------------------------------------------|----------------|

When F913=1, the slave follows the master to start or stop. Except emergency stop command, please do not send stop command to slave. If slave stops by keypad, slave will trip into ESP.

|                                      |                                                                                                                                                                                                          |                 |
|--------------------------------------|----------------------------------------------------------------------------------------------------------------------------------------------------------------------------------------------------------|-----------------|
| F914 Fault information of slave      | Setting range:<br>Ones: slave fault information<br>0: Not sending fault information<br>1: Sending fault information<br>Tens: master's reaction when it loses slave's response<br>0: No reaction 1: Alarm | Mfr's value: 01 |
| F915 Master action when salve failed | Setting range:<br>0: continue running<br>1: free stop<br>2: Deceleration to stop                                                                                                                         | Mfr's value: 1  |

F914 ones: it is used to decide whether to send slave fault information to master.

Tens: when master loses slave's response (must be on-line status), master will trip into Er44.

When F915=1 or 2, after inverter stops, remove the running command between master and slave, after troubleshooting of slave, master can restart again.

|                                     |                                                        |                |
|-------------------------------------|--------------------------------------------------------|----------------|
| F916 Slave action when master stops | Setting range:<br>1: Free stop 2: Deceleration to stop | Mfr's value: 1 |
|-------------------------------------|--------------------------------------------------------|----------------|

When F913=1, F916 is valid.

When F916 = 1, slave will free stop.

When F916 = 2, slave will stop according to deceleration time.

|                                               |                                                                                                          |                |
|-----------------------------------------------|----------------------------------------------------------------------------------------------------------|----------------|
| F917 Slave following master command selection | Setting range:<br>0: given torque(torque)<br>1: given frequency 1(Droop)<br>2: given frequency 2 (Droop) | Mfr's value: 0 |
|-----------------------------------------------|----------------------------------------------------------------------------------------------------------|----------------|

The information type selection of master and slave must be same.

When F917 = 0, it is suitable for rigid connection occasion. Master must run in vector control mode, slave

must run at torque control, and the limit speed of slave must be set correctly.

When F917 = 1 and 2, it is suitable for flexible connection occasion. Master and slave will work at speed mode and droop control function is valid. When F917=1, the target frequency is master given frequency. When F917=2, master given frequency is present frequency (only valid in VVVF control).

|      |                                       |                           |                     |
|------|---------------------------------------|---------------------------|---------------------|
| F918 | Zero offset of received data (torque) | Setting range:0.00~200.00 | Mfr's value: 100.00 |
| F919 | Gain of received data(torque)         | Setting range:0.00~10.00  | Mfr's value: 1.00   |

F918 and F919 are used to adjust torque received from the master. The adjustment formula is as below:  
 $y = F919 * x + F918 - 100.00$ .

When F918=100.00, it means no zero bias.

|      |                                          |                           |                    |
|------|------------------------------------------|---------------------------|--------------------|
| F920 | Zero offset of received data (frequency) | Setting range:0.00~200.00 | Mfr's value:100.00 |
| F921 | Gain of received data(frequency)         | Setting range:0.00~10.00  | Mfr's value:1.00   |

F920 and F921 are used to adjust frequency received from the master. The adjustment formula is as below:  $y = F921 * x + F920 - 100.00$

When F920=100.00, it means no zero bias.

|      |        |                           |                   |
|------|--------|---------------------------|-------------------|
| F922 | window | Setting range: 0.00~10.00 | Mfr's value: 0.50 |
|------|--------|---------------------------|-------------------|

When F917=0, F922 is valid. It is used to limit the slave speed in torque control mode.

|      |               |                                       |                  |
|------|---------------|---------------------------------------|------------------|
| F923 | Droop control | Setting range: 0.0( Invalid) 0.1~30.0 | Mfr's value: 0.0 |
|------|---------------|---------------------------------------|------------------|

When F917 =1 and 2, droop control is valid when master and slave are both in speed control mode.

Droop control allows tiny speed deviation between master and slave, reasonable droop rate setting needs to be adjusted according to actual situation.

Droop speed= synchronizing frequency \*output torque \* droop rate

inverter actual output frequency = synchronizing frequency – droop speed

For example, when F923 = 7%, synchronizing frequency is 45Hz, output torque is 35%,

Then inverter actual output frequency = 45 - (45 \* 0.35 \* 0.07 ) = 43.90Hz。

|      |                                   |                           |                  |
|------|-----------------------------------|---------------------------|------------------|
| F924 | Time of communication timeout (S) | Setting range: 0.0~3000.0 | Mfr's value: 0.0 |
|------|-----------------------------------|---------------------------|------------------|

when F924=0.0, inverter does not test the timeout.

|      |                                  |                                                                |                  |
|------|----------------------------------|----------------------------------------------------------------|------------------|
| F925 | Master sending data interval (S) | Setting range: 0.000~1.000                                     | Mfr's value: 0.0 |
| F926 | CAN baud rate (kbps)             | Setting range:<br>0: 20 1:50 2:100 3:125<br>4:250 5:500 6:1000 | Mfr's value: 6   |

Please refer to Appendix 8 for master/slave control operation.

|      |                        |                                                    |                |
|------|------------------------|----------------------------------------------------|----------------|
| F928 | BACnet address         | Setting range: 0~127                               | Mfr's value: 1 |
| F929 | BACnet baud rate (bps) | Setting range:<br>0:9600 1: 19200 2: 38400 3:76800 | Mfr's value: 1 |

|      |                                   |                                   |                |
|------|-----------------------------------|-----------------------------------|----------------|
| F930 | Keypad disconnected protection(s) | Setting range: 0~10<br>0: Invalid | Mfr's value: 0 |
|------|-----------------------------------|-----------------------------------|----------------|

When F930 is higher than 0, if keypad is removed or keypad has communication fault, after the delay time, inverter will trip into CE1.

Note: after removing remote keypad and switch to local keypad, user should set F930=0.



## 6.11 PID Parameters

### 6.11.1 Internal PID adjusting and constant pressure water supply

Internal PID adjusting control is used for single pump or double pump automatic constant-pressure water supply, or used for simple close-loop system with convenient operation.

The usage of pressure meter:

As FA02=1: channel AI1

“10V” connect with the power supply of pressure meter, if the power supply of pressure meter is 5V, please supply a 5V power.

“AI1” connect with the pressure signal port of pressure meter

“GND” connect with the grounding of pressure meter

As FA02=2: channel AI2

“10V” connect with the power supply of pressure meter, if the power supply of pressure meter is 5V, please supply a 5V power.

“AI2” connect with the pressure signal port of pressure meter

“GND” connect with the grounding of pressure meter

For current type sensor, two-line 4-20mA signal is inputted to inverter, please connect CM to GND, and 24V is connected to power supply of sensor.

### 6.11.2 Parameters

|                        |                                                                                                 |                |
|------------------------|-------------------------------------------------------------------------------------------------|----------------|
| FA00 Water supply mode | Setting range:<br>0: Single pump (PID control mode)<br>1: Fixed mode<br>2: Timing interchanging | Mfr's value: 0 |
|------------------------|-------------------------------------------------------------------------------------------------|----------------|

When FA00=0 and single pump mode is selected, the inverter only controls one pump. The control mode can be used in the closed-loop control system, for example, pressure, flow.

When FA00=1, one motor is connected with converter pump or general pump all the time.

When FA00=2, two pumps are interchanging to connect with inverter for a fixed period of time, this function should be selected. The duration time is set by FA25.

|                                        |                                                                                                                  |                |
|----------------------------------------|------------------------------------------------------------------------------------------------------------------|----------------|
| FA01 PID adjusting target given source | Setting range:<br>0: FA04 1: AI1 2: AI2<br>3: AI3 (Potentiometer on the keypad)<br>4: FI (pulse frequency input) | Mfr's value: 0 |
|----------------------------------------|------------------------------------------------------------------------------------------------------------------|----------------|

When FA01=0, PID adjusting target is given by FA04 or MODBUS.

When FA01=1, PID adjusting target is given by external analog AI1.

When FA01=2, PID adjusting target is given by external analog AI2.

When FA01=3, PID adjusting target is given by the AI3 potentiometer on the keypad.

When FA01=4, PID adjusting target is given by FI pulse frequency (DI1 terminal).

|                                          |                                                                                                                                              |                |
|------------------------------------------|----------------------------------------------------------------------------------------------------------------------------------------------|----------------|
| FA02 PID adjusting feedback given source | Setting range:<br>1: AI1 2: AI2<br>3: FI (pulse frequency input)<br>4: reserved<br>5: Running current<br>6: Output power<br>7: Output torque | Mfr's value: 1 |
|------------------------------------------|----------------------------------------------------------------------------------------------------------------------------------------------|----------------|

When FA02=1, PID feedback signal is given by external analog AI1.

When FA02=2, PID feedback signal is given by external analog AI2.

When FA02=3, PID feedback signal is given by FI pulse frequency input.

When FA02=5, PID feedback signal is given by inverter running current.

When FA02=6, PID feedback signal is given by output power.

When FA02=7, PID feedback signal is given by output torque.

|                                                 |            |                    |
|-------------------------------------------------|------------|--------------------|
| FA03 Max limit of PID adjusting (%)             | FA04~100.0 | Mfr's value: 100.0 |
| FA04 Digital setting value of PID adjusting (%) | FA05~FA03  | Mfr's value: 50.0  |
| FA05 Min limit of PID adjusting (%)             | 0.0~FA04   | Mfr's value: 0.0   |

When negative feedback adjusting is valid, if pressure is higher than max limit of PID adjusting, pressure protection will occur. If inverter is running, it will free stop, and "nP" is displayed. When positive feedback adjusting is valid, if pressure is higher than Max limit, it indicates that feedback pressure is too low, inverter should accelerate or a linefrequency should be added to increase the displacement.

When FA01=0, the value set by FA04 is digital setting reference value of PID adjusting.

When positive feedback adjusting is valid, if pressure is higher than min limit of PID adjusting, pressure protection will occur. If inverter is running, it will free stop, and "nP" is displayed. When negative feedback adjusting, if pressure is higher than min limit, it indicates that feedback pressure is too low, inverter should accelerate or a linefrequency should be added to increase the displacement.

For example: if the range of pressure meter is 0-1.6MPa, then setting pressure is  $1.6*70\%=1.12\text{MPa}$ , and the max limit pressure is  $1.6*90\%=1.44\text{MPa}$ , and the min limit pressure is  $1.6*5\%=0.08\text{MPa}$ .

|                   |                                              |                |
|-------------------|----------------------------------------------|----------------|
| FA06 PID polarity | 0: Positive feedback<br>1: Negative feedback | Mfr's value: 1 |
|-------------------|----------------------------------------------|----------------|

When FA06=0, the higher feedback value is, the higher the motor speed is. This is positive feedback.

When FA06=1, the lower the feedback value is, the higher the motor speed is. This is negative feedback.

|                                  |                                    |                |
|----------------------------------|------------------------------------|----------------|
| FA07 Dormancy function selection | Setting range: 0: Valid 1: Invalid | Mfr's value: 1 |
|----------------------------------|------------------------------------|----------------|

When FA07=0, if inverter runs at the min frequency FA09 for a period time set by FA10, inverter will stop.

When FA07=1, the dormancy function is invalid.

|                                          |                                       |                   |
|------------------------------------------|---------------------------------------|-------------------|
| FA09 Min frequency of PID adjusting (Hz) | Setting range:<br>Max(F112, 0.1)~F111 | Mfr's value: 5.00 |
|------------------------------------------|---------------------------------------|-------------------|

The min frequency is set by FA09 when PID adjusting is valid.

|                              |                          |                   |
|------------------------------|--------------------------|-------------------|
| FA10 Dormancy delay time (S) | Setting range: 0.0~500.0 | Mfr's value: 15.0 |
|------------------------------|--------------------------|-------------------|

When FA07=0, inverter runs at min frequency FA09 for a period time set by FA10, inverter will free stop and enter into the dormancy status, "np" is displayed.

|                          |                         |                  |
|--------------------------|-------------------------|------------------|
| FA11 Wake delay time (S) | Setting range: 0.0~3000 | Mfr's value: 3.0 |
|--------------------------|-------------------------|------------------|

After the wake delay time, if the pressure is lower than min limit pressure (Negative feedback), inverter will begin running immediately, or else, inverter will be in the dormancy status.

|                                  |                                                         |                   |
|----------------------------------|---------------------------------------------------------|-------------------|
| FA67 Dormancy mode               | Setting range: 0: dormancy mode 1<br>1: dormancy mode 2 | Mfr's value: 0    |
| FA68 Given pressure offset 1 (%) | Setting range: 0.0~100.0                                | Mfr's value: 30.0 |
| FA69 Given pressure offset 2 (%) | Setting range: 0.0~100.0                                | Mfr's value: 30.0 |

When FA67=0, inverter will be awoken according to FA03 and FA05.

If FA67=1 and FA06=1, when pressure is higher than target pressure, and PID adjusts to min frequency, inverter will enter into dormancy status after the setting time of FA10. If inverter is in the dormancy status and pressure is lower than target pressure-FA69, inverter will be awoken after wake delay time.

If FA06=0, when pressure is lower than target pressure, and PID adjusts to min frequency, inverter will free stop and enter into dormancy status after the setting time of FA10. If inverter is in the dormancy status, when pressure is higher than target pressure + FA68, inverter will be awoken after weak delay time.

|                            |                          |                    |
|----------------------------|--------------------------|--------------------|
| FA12 PID max frequency(Hz) | Setting range: FA09~F111 | Mfr's value: 50.00 |
|----------------------------|--------------------------|--------------------|

When PID is valid, FA12 is used to set the max frequency.

|                                              |                     |                |
|----------------------------------------------|---------------------|----------------|
| FA18 Whether PID adjusting target is changed | 0: Invalid 1: Valid | Mfr's value: 1 |
|----------------------------------------------|---------------------|----------------|

When FA18=0 and FA01≠0, PID adjusting target cannot be changed.

|                              |                           |                   |
|------------------------------|---------------------------|-------------------|
| FA19 Proportion Gain P       | Setting range: 0.00~10.00 | Mfr's value: 0.30 |
| FA20 Integration time I (S)  | Setting range: 0.1~100.0  | Mfr's value: 0.3  |
| FA21 Differential time D (S) | Setting range: 0.0~10.0   | Mfr's value: 0.0  |
| FA22 PID sampling period (S) | Setting range: 1~500      | Mfr's value: 5    |

Increasing proportion gain, decreasing integration time and increasing differential time can increase the dynamic response of PID closed-loop system. But if P is too high, I is too low or D is too high, system will not be steady.

PID adjusting period is set by FA22. It affects PID adjusting speed.

The following is PID adjusting arithmetic.

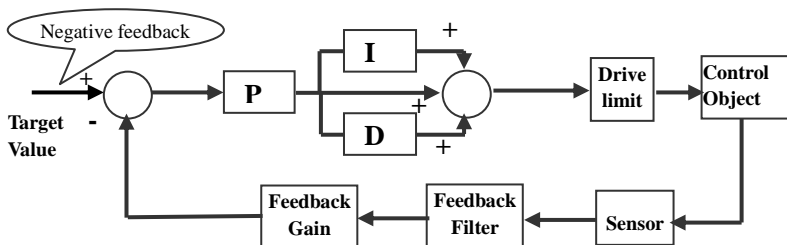

|                                              |                                    |                |
|----------------------------------------------|------------------------------------|----------------|
| FA23 PID negative frequency output selection | Setting range: 0: Invalid 1: Valid | Mfr's value: 0 |
|----------------------------------------------|------------------------------------|----------------|

When FA23=1, PID adjustor can output negative frequency.

|                                    |                                  |                  |
|------------------------------------|----------------------------------|------------------|
| FA24 Switching Timing unit setting | Setting range: 0: hour 1: minute | Mfr's value: 0   |
| FA25 Switching Timing Setting      | 1~9999                           | Mfr's value: 100 |

Switching time is set by F525. The unit is set by F524.

|                                                     |                                                                                                                     |                 |
|-----------------------------------------------------|---------------------------------------------------------------------------------------------------------------------|-----------------|
| FA26 Under-load protection mode                     | Setting Range<br>0: No protection<br>1: Protection by contactor<br>2: Protection by PID<br>3: Protection by current | Mfr's value: 0  |
| FA27 Current threshold of under-load protection (%) | Setting range: 10~150                                                                                               | Mfr's value: 80 |
| FA66 Duration time of under-load protection (S)     | Setting range: 0~60                                                                                                 | Mfr's value: 20 |

Note: the percent of under-load protection current corresponds to motor rated current.

Under-load protection is used to save energy. For some pumps device, when the output power is too low, the efficiency will get worse, so we suggest that the pumps should be closed.

During the running process, if the load decreases to zero suddenly, it means the mechanical part is broken. For example, belt is broken or water pump is dried up. Under-load protection must occur.

When FA26=1, water signal and lack water signal is controlled by two input terminals. When the lack water terminal is valid, inverter will enter into the protection status, and EP1 is displayed. When the water terminal is valid, inverter will deactivate EP1 fault automatically.

When FA26=2, PID adjusting frequency runs to max frequency, if inverter current is lower than the product FA27 and rated current, inverter will enter PID under-load protection status immediately, and EP2 is

displayed.

When FA26=3, if inverter current is lower than the product of FA27 and rated current, after duration time of FA66, inverter will enter under-load protection, and EP3 is displayed.

|                                         |        |                 |
|-----------------------------------------|--------|-----------------|
| FA28 Waking time after protection (min) | 1~3000 | Mfr's value: 60 |
|-----------------------------------------|--------|-----------------|

After the duration time of FA28, inverter will judge that whether the under-load protection signal disappears. If malfunction is resetted, inverter will run again. Or else inverter will wait until malfunction is resetted. User can reset the inverter by pressing "stop/reset", inverter will stop.

|                                                        |           |                   |
|--------------------------------------------------------|-----------|-------------------|
| FA29 PID dead time (%)                                 | 0.0~10.0  | Mfr's value: 2.0  |
| FA30 Running Interval of restarting converter pump (S) | 2.0~999.9 | Mfr's value: 20.0 |
| FA31 Delay time of starting general pumps (S)          | 0.1~999.9 | Mfr's value: 30.0 |
| FA32 Delay time of stopping general pumps (S)          | 0.1~999.9 | Mfr's value: 30.0 |

FA29, PID dead time has two functions. First, setting dead time can restrain PID adjustor oscillation. The greater this value is, the lighter PID adjustor oscillation is. But if the value of FA29 is too high, PID adjusting precision will decrease. For example: when FA29=2.0% and FA04=70, PID adjusting will not invalid during the feedback value from 68 to 72.

Second, FA29 is set to PID dead time when starting and stopping general pumps by PID adjusting. When negative feedback adjusting is valid, if feedback value is lower than value FA04-FA29 (which equal to set value MINUS dead-time value), inverter will delay the set time of FA31, and then start the general pump. If feedback value is higher than value FA04+FA29 (which equal to set value PLUS dead-time value), inverter will delay the set time of FA32, then stop the general pump.

·When starting general pump or interchange time is over, inverter will free stop. After starting general pump, inverter will delay the set time of FA30, and restart converter pump.

·When inverter drives two pumps and negative feedback adjusting, if the frequency already reach the max value and after the delay time (FA31), the pressure value is still lower than the value, then the inverter will stop output immediately and motor will freely stop. At the same time, the general pump will be started. After the general pump is fully run, if the present pressure is higher than the set value, inverter will low down the output to the min frequency. After delaying the set time (FA32), inverter will stop the general pump and start converter pump.

·When inverter drives two pumps and positive feedback adjusting, if the frequency already reach the max value and after the delay time (FA31), the pressure value still higher than the value, then the inverter will stop output immediately and motor will freely stop. At the same time the general pump will be started. After the general pump runs, if the present pressure is lower than the set value, inverter will low down the output to the min frequency. After delaying the set time (FA32), inverter will stop the general pump and start converter pump.

|                                                    |                                         |                |
|----------------------------------------------------|-----------------------------------------|----------------|
| FA33 stop mode when constant pressure water supply | 0: free stop<br>1: deceleration to stop | Mfr's value: 0 |
|----------------------------------------------------|-----------------------------------------|----------------|

FA33 is used to set the stop mode after inverter stops converter pump or trips into nP and EP.

|                                      |                             |                |
|--------------------------------------|-----------------------------|----------------|
| FA36 Whether No.1 relay is available | 0: unavailable 1: available | Mfr's value: 0 |
| FA37 Whether No.2 relay is available | 0: unavailable 1: available | Mfr's value: 0 |

No 1 relay corresponds to the terminal DOI in the control PCB, No 2 relay corresponds to the terminal TA/TC

|                                   |                                                                                  |                   |
|-----------------------------------|----------------------------------------------------------------------------------|-------------------|
| FA38 Proportion gain Kp2          | Setting range: 0.00~10.00                                                        | Mfr's value: 0.30 |
| FA39 Integration time Ki2(S)      | Setting range: 0.1~100.0                                                         | Mfr's value: 0.3  |
| FA40 Differential time Kd2(S)     | Setting range: 0.0~10.0                                                          | Mfr's value: 0.0  |
| FA41 PI parameter switchover type | Setting range: 0: no switchover<br>1: reserved 2: Auto switchover<br>3: reserved | Mfr's value: 0    |
| FA42 Switchover error 1           | Setting range: FA05~FA43                                                         | Mfr's value: 0.0  |
| FA43 Switchover error 2           | Setting range: FA42~FA03                                                         | Mfr's value: 0.0  |

FA38~FA40 is the second group of PID parameters. They can be used with the first group parameters separately.

When FA41=0, the first group PID parameters are used. The parameters are FA19~FA21.

When FA41=2, if the current error(difference between PID given value and PID feedback) is higher than FA43, the second group of PID parameters will be used. When the current error is lower than FA42, the first group of PID parameters will be used. When current error is between error 1 and error 2, PID will use transition parameters.

|                                          |                     |                 |
|------------------------------------------|---------------------|-----------------|
| FA47 The sequence of starting No 1 relay | Setting range: 1~20 | Mfr's value: 20 |
| FA48 The sequence of starting No 2 relay | Setting range: 1~20 | Mfr's value: 20 |

The sequence of starting relays is set by FA47~FA48. The setting value of FA47 and FA48 must be different with each other, or else "Err5" is displayed in the keypad.

|                                    |                          |                   |
|------------------------------------|--------------------------|-------------------|
| FA58 Fire pressure given value (%) | Setting range: 0.0~100.0 | Mfr's value: 80.0 |
|------------------------------------|--------------------------|-------------------|

FA58 is also called second pressure, when the fire control terminal is valid, pressure target value will switch into second pressure value.

|                          |                                                                                   |                |
|--------------------------|-----------------------------------------------------------------------------------|----------------|
| FA59 Emergency fire mode | Setting range:<br>0: Invalid 1: Emergency fire mode 1<br>2: Emergency fire mode 2 | Mfr's value: 0 |
|--------------------------|-----------------------------------------------------------------------------------|----------------|

When emergency fire mode is valid and emergency fire terminal is valid, inverter will be forbidden operating and protecting (When OC and OE protection occur, inverter will reset automatically and start running). And inverter will run at the frequency of FA60 or target frequency until inverter is broken.

Emergency fire mode 1: when the terminal is valid, inverter will run at target frequency.

Emergency fire mode 2: when the terminal is valid, inverter will run at the frequency of FA60.

|                                          |                          |                 |
|------------------------------------------|--------------------------|-----------------|
| FA60 Running frequency of emergency fire | Setting range: F112~F111 | Mfr's value: 50 |
|------------------------------------------|--------------------------|-----------------|

When the emergency fire mode 2 is valid and the fire terminal is valid, inverter will run at the frequency set by FA60.

|                                                      |                    |                |
|------------------------------------------------------|--------------------|----------------|
| FA62 when fire emergency control terminal is invalid | Setting range: 0~1 | Mfr's value: 0 |
|------------------------------------------------------|--------------------|----------------|

When FA62=0, inverter keeps working at fire emergency mode

When FA62=1, inverter will quit from fire emergency mode.

### 6.13 Torque control parameters

|                                     |                                                           |   |
|-------------------------------------|-----------------------------------------------------------|---|
| FC00 Speed/torque control selection | 0: Speed control 1: Torque control 2: Terminal switchover | 0 |
|-------------------------------------|-----------------------------------------------------------|---|

0: speed control. Inverter will run by setting frequency, and output torque will automatically match with the torque of load, and output torque is limited by max torque (set by manufacture.)

1: Torque control. Inverter will run by setting torque, and output speed will automatically match with the speed of load, and output speed is limited by max speed (set by FC23 and FC25). Please set the proper torque and speed limited.

2: Terminal switchover. User can set DIX terminal as torque/speed switchover terminal to realize switchover between torque and speed. When the terminal is valid, torque control is valid. When the terminal is invalid, speed control is valid.

|      |                             |           |     |
|------|-----------------------------|-----------|-----|
| FC02 | Torque accel/decel time (S) | 0.1~100.0 | 1.0 |
|------|-----------------------------|-----------|-----|

The time is for inverter to run from 0% to 100% of rated torque.

|      |                      |                                                                                                                                          |   |
|------|----------------------|------------------------------------------------------------------------------------------------------------------------------------------|---|
| FC06 | Torque given channel | 0: Digital given (FC09)<br>1: Analog input AI1<br>2: Analog input AI2<br>3: Analog input AI3<br>4: Pulse input channel FI<br>5: Reserved | 0 |
|------|----------------------|------------------------------------------------------------------------------------------------------------------------------------------|---|

When FC06=4, only DI1 terminal can be selected because only DI1 terminal has the pulse input function.

|      |                                |         |       |
|------|--------------------------------|---------|-------|
| FC07 | Torque given coefficient       | 0~3.000 | 3.000 |
| FC09 | Torque given command value (%) | 0~300.0 | 100.0 |

FC07: when input given torque reaches max value, FC07 is the ratio of inverter output torque and motor rated torque. For example, if FC06=1, F402=10.00, FC07=3.00, when AI1 channel output 10V, the output torque of inverter is 3 times of motor rated torque.

|      |                                     |                                                                                                                                          |       |
|------|-------------------------------------|------------------------------------------------------------------------------------------------------------------------------------------|-------|
| FC14 | Offset torque given channel         | 0: Digital given (FC17)<br>1: Analog input AI1<br>2: Analog input AI2<br>3: Analog input AI3<br>4: Pulse input channel FI<br>5: Reserved | 0     |
| FC15 | Offset torque coefficient           | 0~0.500                                                                                                                                  | 0.500 |
| FC16 | Offset torque cut-off frequency (%) | 0~100.0                                                                                                                                  | 10.0  |
| FC17 | Offset torque command value (%)     | 0~50.0                                                                                                                                   | 10.00 |

· Offset torque is used to output larger start torque which equals to setting torque and offset torque when motor drives big inertia load. When actual speed is lower than the setting frequency by FC16, offset torque is given by FC14. When actual speed is higher than the setting frequency by FC16, offset torque is 0.

· When FC14≠0, and offset torque reaches max value, FC15 is the ratio of offset torque and motor rated torque. For example: if FC14=1, F402=10.00 and FC15=0.500, when AI1 channel outputs 10V, offset torque is 50% of motor rated torque.

|      |                               |                                                                                                                                          |      |
|------|-------------------------------|------------------------------------------------------------------------------------------------------------------------------------------|------|
| FC22 | Forward speed limited channel | 0: Digital given (FC23)<br>1: Analog input AI1<br>2: Analog input AI2<br>3: Analog input AI3<br>4: Pulse input channel FI<br>5: Reserved | 0    |
| FC23 | Forward speed limited (%)     | 0~100.0                                                                                                                                  | 10.0 |

|      |                               |                                                                                                                                    |      |
|------|-------------------------------|------------------------------------------------------------------------------------------------------------------------------------|------|
| FC24 | Reverse speed limited channel | 0: Digital given (FC25)<br>1: Analog input AI1<br>2: Analog input AI2<br>3: Analog input AI3<br>4: Impulse input FI<br>5: Reserved | 0    |
| FC25 | Reverse speed limited (%)     | 0~100.0                                                                                                                            | 10.0 |

Speed limited FC23/FC25: if given speed reaches max value, they are used to set percent of inverter output frequency and max frequency F111.

|      |                                   |                                                                                                                                          |        |
|------|-----------------------------------|------------------------------------------------------------------------------------------------------------------------------------------|--------|
| FC28 | Electric torque limit channel     | 0: Digital given (FC30)<br>1: Analog input AI1<br>2: Analog input AI2<br>3: Analog input AI3<br>4: Pulse input channel FI<br>5: Reserved | 0      |
| FC29 | Electric torque limit coefficient | 0~3.000                                                                                                                                  | 3.000  |
| FC30 | Electric torque limit (%)         | 0~300.0                                                                                                                                  | 200.0  |
| FC33 | Braking torque limit channel      | 0: Digital given (FC35)<br>1: Analog input AI1<br>2: Analog input AI2<br>3: Analog input AI3<br>4: Pulse input channel FI<br>5: Reserved | 0      |
| FC34 | Braking torque limit coefficient  | 0~3.000                                                                                                                                  | 3.000  |
| FC35 | Braking torque limit (%)          | 0~300.0                                                                                                                                  | 200.00 |

When motor is in the electric status, output torque limit channel is set by FC28. When FC28 does not equal to 0, limit torque is set by FC29. When FC28=0, limit torque is set by FC30.

When motor is in the Braking status, Braking torque limit channel is set by FC31. When FC33 does not equal to 0, limit torque is set by FC34. When FC33=0, limit torque is set by FC35.

|                                       |                                       |                    |
|---------------------------------------|---------------------------------------|--------------------|
| FC48 Torque switchover enabled        | Setting range:<br>0: Invalid 1: Valid | Mfr's value: 0     |
| FC49 Current-limiting point 2 (%)     | Setting range: F608~200               | Mfr's value: 190   |
| FC50 Frequency switchover point 1(Hz) | Setting range: 1.00~FC51              | Mfr's value: 10.00 |
| FC51 Frequency switchover point 2(Hz) | Setting range: FC50~F111              | Mfr's value: 20.00 |

FC48 is used to limit max torque or max current during running process. In VF and auto torque promotion mode, it is used to limit current, in vector control mode. It is used to limit torque.

FC49 is the percentage of rated current in VF and auto torque promotion mode. FC49 is the percentage of rated torque in vector control mode.

FC50 and FC51 is frequency switchover point when torque or current change. Please see below Fig.

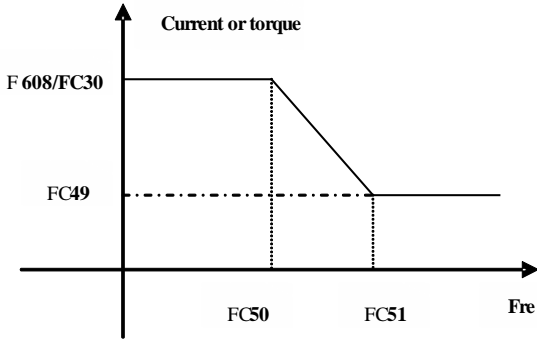

**6.14 Parameters of the second motor**

Please refer to Appendix 6 for the related function code, and please refer to F8 section for parameters explanations.

**6.15 Parameters display**

|                                             |  |  |
|---------------------------------------------|--|--|
| H000 Running frequency/target frequency(Hz) |  |  |
|---------------------------------------------|--|--|

In stopped status, target frequency is displayed. In running status, running frequency is displayed.

|                                      |  |  |
|--------------------------------------|--|--|
| H001 Actual speed/target speed (rpm) |  |  |
|--------------------------------------|--|--|

In stopped status, actual speed is displayed. In running status, target speed is displayed.

|                         |  |  |
|-------------------------|--|--|
| H002 Output current (A) |  |  |
|-------------------------|--|--|

In running status, output current is displayed. In stopped status, H002=0.

|                         |  |  |
|-------------------------|--|--|
| H003 Output voltage (V) |  |  |
|-------------------------|--|--|

In running status, output voltage is displayed. In stopped status, H003=0.

|                      |  |  |
|----------------------|--|--|
| H004 Bus voltage (V) |  |  |
|----------------------|--|--|

Bus voltage is displayed by H004.

|                       |  |  |
|-----------------------|--|--|
| H005 PID feedback (%) |  |  |
|-----------------------|--|--|

PID feedback value is displayed by H005.

|                       |  |  |
|-----------------------|--|--|
| H006 Temperature (°C) |  |  |
|-----------------------|--|--|

Inverter temperature is displayed by H006.

|                  |  |  |
|------------------|--|--|
| H007 Count value |  |  |
|------------------|--|--|

The count value of DI1 input impulse is displayed by H007.

|                   |  |  |
|-------------------|--|--|
| H008 linear speed |  |  |
|-------------------|--|--|

Inverter linear speed is displayed by H008.

|                            |  |  |
|----------------------------|--|--|
| H009 PID setting value (%) |  |  |
|----------------------------|--|--|

PID setting value is displayed by H009.

|                  |  |  |
|------------------|--|--|
| H010 Yarn length |  |  |
|------------------|--|--|

|                             |  |  |
|-----------------------------|--|--|
| H011 central frequency (Hz) |  |  |
|-----------------------------|--|--|

Yarn length and central frequency are displayed by H010 and H011.



|      |                   |  |  |
|------|-------------------|--|--|
| H012 | Output power (KW) |  |  |
|------|-------------------|--|--|

Inverter output power is displayed by H012.

|      |                   |  |  |
|------|-------------------|--|--|
| H013 | Output torque (%) |  |  |
|------|-------------------|--|--|

|      |                   |  |  |
|------|-------------------|--|--|
| H014 | Target torque (%) |  |  |
|------|-------------------|--|--|

Inverter output torque is displayed by H013 and target torque is displayed by H014.

|      |                                   |  |  |
|------|-----------------------------------|--|--|
| H015 | Encoder phase sequence adjustment |  |  |
|------|-----------------------------------|--|--|

H015 is used to test whether the encoder direction is same with setting direction, please refer to F854.

|      |                               |  |  |
|------|-------------------------------|--|--|
| H016 | Limit-voltage reference value |  |  |
|------|-------------------------------|--|--|

H016 is used to display limit-voltage reference value.

|      |                                           |  |  |
|------|-------------------------------------------|--|--|
| H017 | Current stage speed for multi-stage speed |  |  |
|------|-------------------------------------------|--|--|

In multi-stage speed mode, current stage speed is displayed by H017.

|      |                          |  |  |
|------|--------------------------|--|--|
| H018 | Frequency of input pulse |  |  |
|------|--------------------------|--|--|

Input pulse frequency of DI1 terminal is displayed by H018, the unit is 0.01

|      |                     |  |  |
|------|---------------------|--|--|
| H019 | Feedback speed (Hz) |  |  |
|------|---------------------|--|--|

|      |                      |  |  |
|------|----------------------|--|--|
| H020 | Feedback speed (rpm) |  |  |
|------|----------------------|--|--|

Feedback speed is displayed as frequency by H019. Feedback speed is displayed as speed by H020.

|      |                        |  |  |
|------|------------------------|--|--|
| H021 | AI1 voltage (digital ) |  |  |
|------|------------------------|--|--|

|      |                        |  |  |
|------|------------------------|--|--|
| H022 | AI2 voltage (digital ) |  |  |
|------|------------------------|--|--|

|      |                        |  |  |
|------|------------------------|--|--|
| H023 | AI3 voltage (digital ) |  |  |
|------|------------------------|--|--|

Analog input voltage is display by H021, H022 and H023.

|      |                                |  |  |
|------|--------------------------------|--|--|
| H025 | Current power-on time (minute) |  |  |
|------|--------------------------------|--|--|

|      |                               |  |  |
|------|-------------------------------|--|--|
| H026 | Current running time (minute) |  |  |
|------|-------------------------------|--|--|

Current power-on time and running time are displayed by H025 and H026.

|      |                           |  |  |
|------|---------------------------|--|--|
| H027 | Input pulse frequency(Hz) |  |  |
|------|---------------------------|--|--|

Input pulse frequency is displayed by H027, the unit is 1Hz.

|      |                              |  |  |
|------|------------------------------|--|--|
| H030 | Main frequency source X (Hz) |  |  |
|------|------------------------------|--|--|

|      |                                    |  |  |
|------|------------------------------------|--|--|
| H031 | Accessorial frequency source Y(Hz) |  |  |
|------|------------------------------------|--|--|

Main frequency and accessorial frequency are displayed by H030 and H031.

|      |                       |  |  |
|------|-----------------------|--|--|
| H033 | Torque sent by master |  |  |
|------|-----------------------|--|--|

|      |                          |  |  |
|------|--------------------------|--|--|
| H034 | Frequency sent by master |  |  |
|------|--------------------------|--|--|

|      |                    |  |  |
|------|--------------------|--|--|
| H035 | Quantity of slaves |  |  |
|------|--------------------|--|--|

H033 is sued to display percentage of rated torque.

H034 is used to display the frequency sent by master.

H035 is used to display the quantity of slaves.

|      |                            |  |  |
|------|----------------------------|--|--|
| H036 | Accumulative power-on time |  |  |
|------|----------------------------|--|--|

|      |                           |  |  |
|------|---------------------------|--|--|
| H037 | Accumulative running time |  |  |
|------|---------------------------|--|--|

## Appendix 1 Trouble Shooting

When malfunction occurs to inverter, don't run by resetting immediately. Check any causes and get it removed if there is any.

Take counter measures by referring to this manual in case of any malfunctions on inverter. Should it still be unsolved, contact the manufacturer. Never attempt any repairing without due authorization.

Table 1-1 **Inverter's Common Cases of Malfunctions**

| Fault    | Description                        | Causes                                                                                                                                                                                                        | Countermeasures                                                                                                                                                                                                                                           |
|----------|------------------------------------|---------------------------------------------------------------------------------------------------------------------------------------------------------------------------------------------------------------|-----------------------------------------------------------------------------------------------------------------------------------------------------------------------------------------------------------------------------------------------------------|
| Err0     | Prohibition modify function code   | * prohibition modify the function code during running process.                                                                                                                                                | * Please modify the function code in stopped status.                                                                                                                                                                                                      |
| Err1     | Wrong password                     | *Enter wrong password when password is valid<br>* Do not enter password when modifying function code.                                                                                                         | * Please enter the correct password.                                                                                                                                                                                                                      |
| 2: O.C.  | Over-current                       | * too short acceleration time                                                                                                                                                                                 | *prolong acceleration time;                                                                                                                                                                                                                               |
| 16: OC1  | Over-current 1                     | * short circuit at output side<br>* locked rotor with motor                                                                                                                                                   | *whether motor cable is broken;<br>*check if motor overloads;                                                                                                                                                                                             |
| 67: OC2  | Over-current 2                     | * Too heavy load.<br>* parameter tuning is not correct.                                                                                                                                                       | *reduce V/F compensation value<br>* measure parameter correctly.                                                                                                                                                                                          |
| 3: O.E.  | DC Over-Voltage                    | *supply voltage too high;<br>*load inertia too big<br>*deceleration time too short;<br>*motor inertia rise again<br>* bad effect of dynamic braking<br>*parameter of rotary speed loop PID is set abnormally. | *check if rated voltage is input;<br>*add braking resistance(optional);<br>*increase deceleration time<br>* Enhancing the dynamic braking effect<br>*set the parameter of rotary speed loop PID correctly.<br>* Change to VF control for centrifugal fan. |
| 4: P.F1. | Input Phase loss                   | *phase loss with input power                                                                                                                                                                                  | *check if power input is normal;<br>*check if parameter setting is correct.                                                                                                                                                                               |
| 5: O.L1  | Inverter Overload                  | * load too heavy                                                                                                                                                                                              | *reduce load; *check drive ratio;<br>*increase inverter's capacity                                                                                                                                                                                        |
| 6: L.U.  | Under-Voltage Protection           | *input voltage on the low side                                                                                                                                                                                | *check if supply voltage is normal<br>*check if parameter setting is correct.                                                                                                                                                                             |
| 7: O.H.  | Radiator Overheat                  | *environment temperature too high;<br>*radiator too dirty<br>*install place not good for ventilation;<br>*fan damaged<br>* Carrier wave frequency or compensation curve is too high.                          | *improve ventilation;<br>*clean air inlet and outlet and radiator;<br>*install as required;<br>*change fan<br>* Decrease carrier wave frequency or compensation curve.                                                                                    |
| 8: O.L2  | Motor Overload                     | * load too heavy                                                                                                                                                                                              | *reduce load; *check drive ratio;<br>*increase motor's capacity                                                                                                                                                                                           |
| 11: ESP  | External fault                     | *External emergency-stop terminal is valid.                                                                                                                                                                   | *Check external fault.                                                                                                                                                                                                                                    |
| 12: Err3 | Current malfunction before running | *Current alarm signal exists before running.                                                                                                                                                                  | *check if control board is connected with power board well.<br>*ask for help from manufacture.                                                                                                                                                            |
| 13: Err2 | Parameters tuning wrong            | * Do not connect motor when measuring parameters                                                                                                                                                              | *please connect motor correctly.                                                                                                                                                                                                                          |

|            |                                                            |                                                                                                                                                |                                                                                                             |
|------------|------------------------------------------------------------|------------------------------------------------------------------------------------------------------------------------------------------------|-------------------------------------------------------------------------------------------------------------|
| 15: Err4   | Current zero excursion malfunction                         | *Flat cable is loosened.<br>*Current detector is broken.                                                                                       | *check the flat cable.<br>*ask for help from manufacture.                                                   |
| 17: PF0    | Output Phase loss                                          | * Motor is broken<br>* Motor wire is loose.<br>* Inverter is broken                                                                            | * check if wire of motor is loose.<br>* check if motor is broken.                                           |
| 18: AErr   | Line disconnected                                          | * Analog signal line disconnected<br>* Signal source is broken.                                                                                | * Change the signal line.<br>* Change the signal source.                                                    |
| 19: EP3    | Inverter under-load                                        | * Water pump dries up.<br>* Belt is broken.<br>* Equipment is broken.                                                                          | * Supply water for pump<br>* Change the belt.<br>* Repair the equipment.                                    |
| 20: EP/EP2 |                                                            |                                                                                                                                                |                                                                                                             |
| 22: nP     | Pressure control                                           | * Pressure is too high when negative feedback.<br>* Pressure is too low when positive feedback.<br>* Inverter enters into the dormancy status. | * Decrease the min frequency of PID.<br>* Reset inverter to normal status.                                  |
| 23: Err5   | PID parameters are set wrong.                              | * PID parameters are set wrong.                                                                                                                | * Set the parameters correctly.                                                                             |
| 26: GP     | Earth fault protection (S2/T2 does not have GP protection) | *Motor cable is damaged, short connected to grounding.<br>*Motor isolation is damaged, short connected to grounding.<br>*inverter fault.       | *change a new cable.<br>*repair the motor.<br>*contact manufacturer.                                        |
| 27: PG     | Encoder fault                                              | *Encoder installation fault<br>*Encoder fault<br>*Encoder line number setting fault                                                            | *Check the installation and connection<br>*Check encoder<br>*Setting F851 correctly                         |
| 32: PCE    | PMSM distuning fault                                       | *motor parameters measurement is wrong.<br>*load is too heavy.                                                                                 | * Measure motor parameters correctly.<br>* Decrease the load.                                               |
| 35: OH1    | PTC overheat protection                                    | *external relay protection.                                                                                                                    | *check external heat protection equipment.                                                                  |
| 44: Er44   | Master loses slave's response                              | *communication fault between master and slave                                                                                                  | * check wiring.<br>*check baud rate<br>*check communication parameters setting                              |
| 45: CE     | Communication timeout error                                | Communication fault                                                                                                                            | *PC/PLC does not send command at fixed time<br>*Check whether the communication line is connected reliably. |
| 47: EEEP   | EEPROM read/write fault                                    | *interference around<br>*EEPROM is damaged.                                                                                                    | * remove interferences<br>*contact manufacturer.                                                            |
| 49: Err6   | Watchdog fault                                             | Watchdog timeout                                                                                                                               | *please check watchdog signal                                                                               |
| 53: CE 1   | Keypad disconnection protection                            | *Keypad disconnection                                                                                                                          | *Check communication line                                                                                   |

Table 1-2

**Motor Malfunction and Counter Measures**

| Malfunction                                 | Items to Be Checked                                                                                                                       | Counter Measures                                                                                                       |
|---------------------------------------------|-------------------------------------------------------------------------------------------------------------------------------------------|------------------------------------------------------------------------------------------------------------------------|
| Motor not Running                           | Wiring correct? Setting correct? Too big with load? Motor is damaged? Malfunction protection occurs?                                      | Get connected with power; Check wiring; Checking malfunction; Reduce load; Check against Table 1-1                     |
| Wrong Direction of Motor Running            | U, V, W wiring correct?<br>Parameters setting correct?                                                                                    | To correct wiring<br>Setting the parameters correctly.                                                                 |
| Motor Turning but Speed Change not Possible | Wiring correct for lines with given frequency?<br>Correct setting of running mode?<br>Too big with load?                                  | To correct wiring;<br>To correct setting; Reduce load                                                                  |
| Motor Speed Too High or Too Low             | Motor's rated value correct? Drive ratio correct? Inverter parameters are set in-corrected? Check if inverter output voltage is abnormal? | Check motor nameplate data; Check the setting of drive ratio; Check parameters setting; Check V/F Characteristic value |
| Motor Running Unstable                      | Too big load? Too big with load change?<br>Phase loss? Motor malfunction.                                                                 | Reduce load; reduce load change, increase capacity;<br>Correct wiring.                                                 |
| Power Trip                                  | Wiring current is too high?                                                                                                               | Check input wiring; Selecting matching air switch; Reduce load; checking inverter malfunction.                         |

## Appendix 2 Reference wiring of water system

### 1. Fixed mode of 1 inverter driving 2 pumps

#### Instructions of wiring:

1. Please connect the wiring according to above wiring, after checking the wiring and close MCCB3.

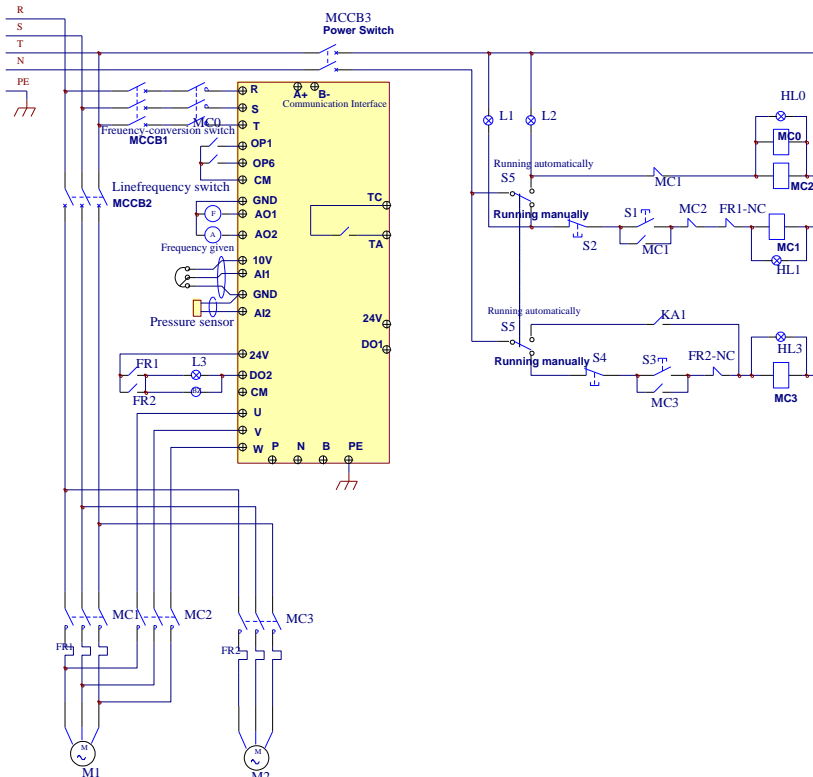

2. Please set F208=1, F203=9, FA00=1, FA36=1, FA37=1, FA47=1, FA48=2, FA04=pressure percentage, FA03=channel limit pressure, and FA05.
3. In manual status, please close power-frequency switch MCCB2. When pressing S1, pump M1 starts working. When pressing S2, M1 stops working. When pressing S3, M2 starts working. When pressing S4, M2 stops working.
4. In automatic status, please close converter-frequency switch MCCB1 and power-frequency switch MCCB2.
  - When inverter is powered on, inverter will run forward by short-connecting DI3 terminal (or run reverse by short-connecting DI4 terminal), M1 will work at power frequency status.
  - If the pressure is not high enough, inverter will accelerate to max frequency. If the pressure is still not high enough after duration time FA31, inverter will free stop and pump M2 will start working at power frequency status. After the duration time of FA30, inverter will start working and M1 works at converter frequency status.
  - When two pumps work at the same time, if pressure is too high, inverter will decelerate to min frequency. If the pressure is still too high after the duration time FA32, M2 will stop working.
  - If one pump M1 works at converter frequency status and inverter works at the min frequency, inverter

will free stop after the duration time FA10, inverter will enter into dormancy status and nP is displayed.

### 5. Rotating mode of 1 inverter driving 2 pumps

Instructions of wiring:

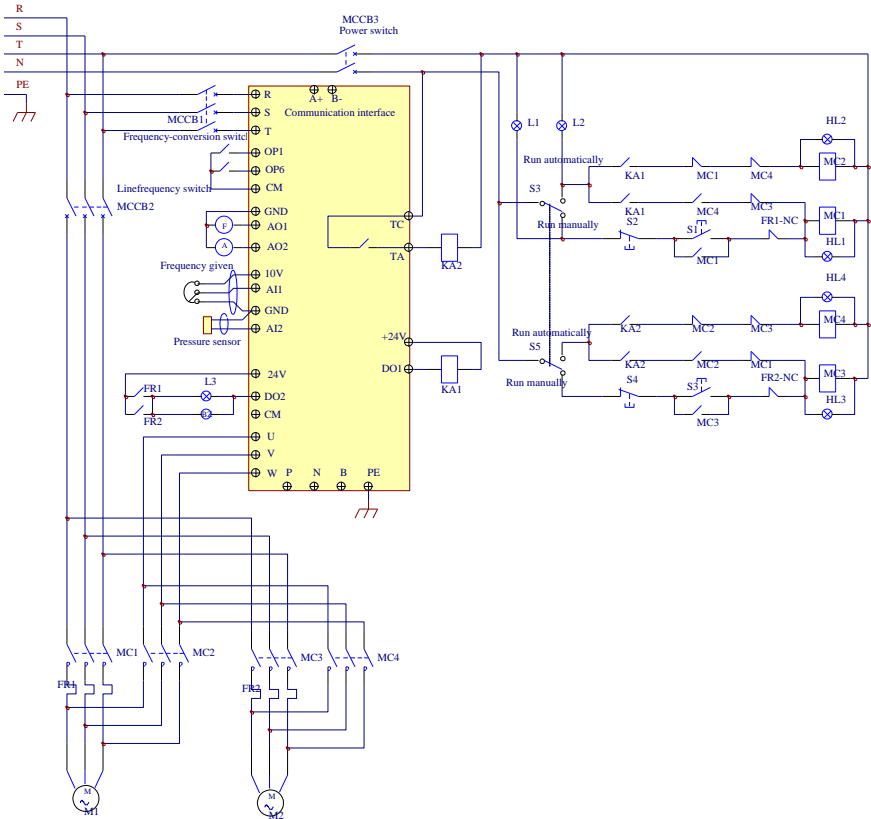

1. Please connect the wiring according to above wiring, after checking the wiring and close MCCB3.
  2. Please set F208=1, F203=9, FA00=2, FA36=1, FA37=1, FA47=1, FA48=2, FA04=pressure percentage, FA03=channel limit pressure, and FA05
  3. In manual status, please close power-frequency switch MCCB2. When pressing S1, pump M1 starts working. When pressing S2, M1 stops working. When pressing S3, M2 starts working. When pressing S4, M2 stops working.
  4. In automatic status, please close converter-frequency switch MCCB1 and power-frequency switch MCCB2.
- When inverter is powered on, KA1 is “action”, and inverter will run forward by short-connecting DI3 terminal, KA2 makes M1 start working at converter frequency status. If the pressure is not high enough, inverter will accelerate to max frequency. If the pressure is still not high enough after duration time FA31, inverter will free stop and pump M2 will start working at power frequency status.

---

After the duration time of FA30, inverter will start working and M1 works at converter frequency status.

- After the duration time FA25, all pumps will free stop, then KA2 is “action”, M2 is converter pump. If the pressure is not high enough, inverter will accelerate to max frequency. If the pressure is still not high enough after duration time FA31, inverter will free stop and KA1 makes M1 start working at power frequency status. After the duration time of FA30, inverter will start working and M2 works at converter frequency status.
- When two pumps work at the same time, if pressure is too high, inverter will decelerate to min frequency. If the pressure is still too high after the duration time FA32, general pump will stop working.
- If one pump works at converter frequency status and inverter works at the min frequency, inverter will free stop after the duration time FA10, inverter will enter into dormancy status and nP is displayed.

## Appendix 3 Products & Structures

E2000 series inverter has its power range between 0.2~800kW. Refer to Tables 3-1 and 3-2 for main data. There may be two (or more than two) kinds of structures for certain products. Please make a clear indication when placing your order.

Inverter should operate under the rated output current, with overload permitted for a short time. However, it shall not exceed the allowable values at working time.

Table 3-1 **Product List of E2000**

| Model        | Applicable Motor (kW) | Rated Current Output | Structure Code | Cooling Mode | Remarks                      |
|--------------|-----------------------|----------------------|----------------|--------------|------------------------------|
| E2000-0004S2 | 0.4                   | 2.5                  | E1             | Air-Cooling  | 1-phase plastic housing      |
| E2000-0007S2 | 0.75                  | 4.5                  | E1             | Air-Cooling  |                              |
| E2000-0015S2 | 1.5                   | 7.0                  | E2             | Air-Cooling  |                              |
| E2000-0022S2 | 2.2                   | 10.0                 | E2             | Air-Cooling  |                              |
| E2000-0002T2 | 0.2                   | 1.5                  | E1             | Air-Cooling  | 3-phase 220V plastic housing |
| E2000-0004T2 | 0.4                   | 2.5                  | E1             | Air-Cooling  |                              |
| E2000-0007T2 | 0.75                  | 4.5                  | E1             | Air-Cooling  |                              |
| E2000-0015T2 | 1.5                   | 7                    | E1             | Air-Cooling  |                              |
| E2000-0022T2 | 2.2                   | 10                   | E2             | Air-Cooling  |                              |
| E2000-0030T2 | 3.0                   | 12                   | E3             | Air-Cooling  |                              |
| E2000-0040T2 | 4.0                   | 17                   | E4             | Air-Cooling  |                              |
| E2000-0055T2 | 5.5                   | 21                   | E5             | Air-Cooling  |                              |
| E2000-0075T2 | 7.5                   | 30                   | E6             | Air-Cooling  |                              |
| E2000-0110T2 | 11                    | 40                   | E6             | Air-Cooling  |                              |
| E2000-0150T2 | 15                    | 55                   | C3             | Air-Cooling  |                              |
| E2000-0185T2 | 18.5                  | 66                   | C3             | Air-Cooling  |                              |
| E2000-0220T2 | 22                    | 76                   | C3             | Air-Cooling  |                              |
| E2000-0300T2 | 30                    | 104                  | C4             | Air-Cooling  |                              |
| E2000-0370T2 | 37                    | 130                  | C5             | Air-Cooling  |                              |
| E2000-0450T2 | 45                    | 155                  | C5             | Air-Cooling  |                              |
| E2000-0550T2 | 55                    | 190                  | C6             | Air-Cooling  |                              |
| E2000-0750T2 | 75                    | 260                  | C7             | Air-Cooling  | 3-phase 380V plastic housing |
| E2000-0007T3 | 0.75                  | 2.0                  | E1             | Air-Cooling  |                              |
| E2000-0015T3 | 1.5                   | 4.0                  | E1             | Air-Cooling  |                              |
| E2000-0022T3 | 2.2                   | 6.5                  | E2             | Air-Cooling  |                              |
| E2000-0030T3 | 3.0                   | 7.0                  | E2             | Air-Cooling  |                              |
| E2000-0040T3 | 4.0                   | 9.0                  | E2             | Air-Cooling  |                              |
| E2000-0055T3 | 5.5                   | 12.0                 | E4             | Air-Cooling  |                              |
| E2000-0075T3 | 7.5                   | 17.0                 | E4             | Air-Cooling  |                              |
| E2000-0110T3 | 11                    | 23.0                 | E5             | Air-Cooling  |                              |
| E2000-0150T3 | 15                    | 32.0                 | E5             | Air-Cooling  |                              |
| E2000-0185T3 | 18.5                  | 38.0                 | E6             | Air-Cooling  |                              |



|              |     |      |     |              |                            |                            |
|--------------|-----|------|-----|--------------|----------------------------|----------------------------|
| E2000-0220T3 | 22  | 44.0 | E6  | Air- Cooling | 3-phase 380V metal housing |                            |
| E2000-0300T3 | 30  | 60   | E6  | Air-Cooling  |                            |                            |
| E2000-0370T3 | 37  | 75   | E7  | Air- Cooling |                            |                            |
| E2000-0450T3 | 45  | 90   | E7  | Air- Cooling |                            |                            |
| E2000-0550T3 | 55  | 110  | C5  | Air-Cooling  |                            |                            |
| E2000-0750T3 | 75  | 150  | C5  | Air- Cooling |                            |                            |
| E2000-0900T3 | 90  | 180  | C6  | Air- Cooling |                            |                            |
| E2000-1100T3 | 110 | 220  | C6  | Air-Cooling  |                            |                            |
| E2000-1320T3 | 132 | 265  | C6  | Air- Cooling |                            |                            |
| E2000-1600T3 | 160 | 320  | C7  | Air- Cooling |                            |                            |
| E2000-1800T3 | 180 | 360  | C8  | Air-Cooling  |                            |                            |
| E2000-2000T3 | 200 | 400  | C9  | Air- Cooling |                            |                            |
| E2000-2200T3 | 220 | 440  | C9  | Air- Cooling |                            |                            |
| E2000-2500T3 | 250 | 480  | CA  | Air-Cooling  |                            |                            |
| E2000-2800T3 | 280 | 530  | CA  | Air- Cooling |                            |                            |
| E2000-3150T3 | 315 | 580  | CB0 | Air- Cooling |                            |                            |
| E2000-3550T3 | 355 | 640  | CB0 | Air-Cooling  |                            |                            |
| E2000-4000T3 | 400 | 690  | CB  | Air- Cooling |                            |                            |
| E2000-1100T3 | 110 | 220  | DC6 | Air- Cooling |                            | 3-phase 380V metal cabinet |
| E2000-1320T3 | 132 | 265  | DD0 | Air-Cooling  |                            |                            |
| E2000-1600T3 | 160 | 320  | DD0 | Air- Cooling |                            |                            |
| E2000-1800T3 | 180 | 360  | DD1 | Air- Cooling |                            |                            |
| E2000-2000T3 | 200 | 400  | DD1 | Air-Cooling  |                            |                            |
| E2000-2200T3 | 220 | 440  | DD1 | Air- Cooling |                            |                            |
| E2000-2500T3 | 250 | 480  | DD2 | Air- Cooling |                            |                            |
| E2000-2800T3 | 280 | 530  | DD2 | Air-Cooling  |                            |                            |
| E2000-3150T3 | 315 | 580  | DD2 | Air- Cooling |                            |                            |
| E2000-3550T3 | 355 | 640  | DD2 | Air- Cooling |                            |                            |
| E2000-4000T3 | 400 | 690  | DD3 | Air-Cooling  |                            |                            |
| E2000-4500T3 | 450 | 770  | DD3 | Air- Cooling |                            |                            |
| E2000-5000T3 | 500 | 860  | DD4 | Air- Cooling |                            |                            |
| E2000-5600T3 | 560 | 950  | DD4 | Air-Cooling  |                            |                            |
| E2000-6300T3 | 630 | 1100 | DD4 | Air- Cooling |                            |                            |
| E2000-7100T3 | 710 | 1300 | D6  | Air- Cooling |                            |                            |
| E2000-8000T3 | 800 | 1500 | D6  | Air- Cooling |                            |                            |

Table 3-2 Structure List

| Structure Code | External Dimension<br>[A×B(B1)×H] <sup>note1</sup> | Mounting Size(W×L) | Mounting Bolt | Remarks         |
|----------------|----------------------------------------------------|--------------------|---------------|-----------------|
| E1             | 80×135 (142) ×138(153)                             | 70×128             | M4            | Plastic Housing |
| E2             | 106×150 (157) ×180(195)                            | 94×170             | M4            |                 |
| E3             | 106×170 (177) ×180(195)                            | 94×170             | M4            |                 |
| E4             | 142×152 (159) ×235(248)                            | 126×225            | M5            |                 |
| E5             | 161×170 (177) ×265(280)                            | 146×255            | M5            |                 |
| E6             | 210×196 (203) ×340(358)                            | 194×330            | M5            |                 |
| E7             | 265×235(242)×435(465)                              | 235×412            | M6            |                 |
| C3             | 265×235×435                                        | 235×412            | M6            | Metal Housing   |
| C4             | 315×234×480                                        | 274×465            | M6            |                 |
| C5             | 360×265×555                                        | 320×530            | M8            |                 |
| C6             | 410×300×630                                        | 370×600            | M10           |                 |
| C7             | 516×326×765                                        | 360×740            | M10           |                 |
| C8             | 560×342×910                                        | 390×882            | M10           |                 |
| C9             | 400×385×1310                                       | 280×1282           | M10           |                 |
| CA             | 535×380×1340                                       | 470×1310           | M10           |                 |
| CB0            | 600×380×1463                                       | 545×1433           | M10           |                 |
| CB             | 600×380×1593                                       | 545×1563           | M10           |                 |
| DC6            | 440×318×1050                                       | 360×240            | M10           | Metal cabinet   |
| DD0            | 500×450×1450                                       | 400×370            | M12           |                 |
| DD1            | 600×500×1650                                       | 500×420            | M12           |                 |
| DD2            | 660×500×1650                                       | 560×420            | M12           |                 |
| DD3            | 800×600×2050                                       | 700×510            | M12           |                 |
| DD4            | 1200×600×2250                                      | 892×394            | M16           |                 |
| D6             | 1700×600×2355                                      | 1489×394           | M16           |                 |

Note 1: the unit is mm.

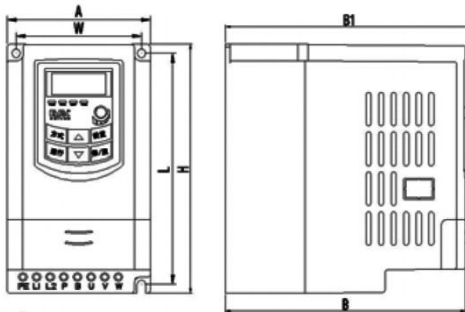

Plastic Profile

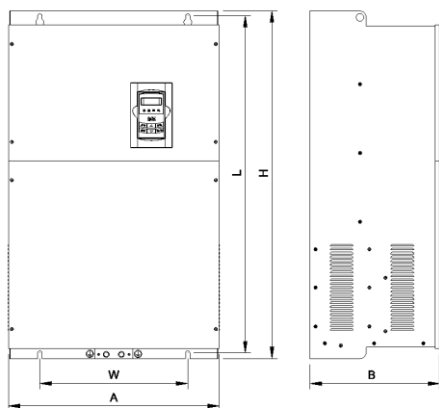

Metal Hanging Profile

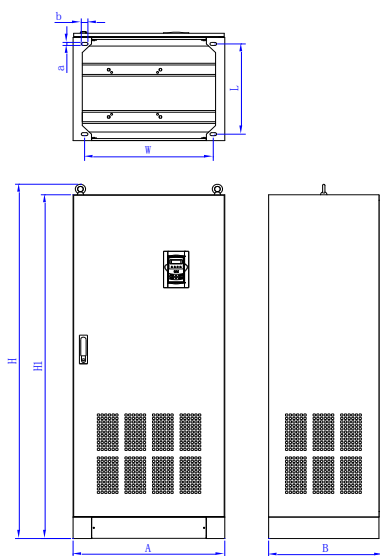

Metal Cabinet profile

Note1: if keypad control unit has potentiometer, the external dimension is B1.

If keypad control unit has no potentiometer, the external dimension is B.

## Appendix 4 Selection of Braking Resistance

| Inverter Models | Applicable Motor Power (kW) | Min resistor value ( $\Omega$ ) | Min power of resistor (W) | Recommended resistor/power       |
|-----------------|-----------------------------|---------------------------------|---------------------------|----------------------------------|
| E2000-0004S2    | 0.4                         | 80                              | 200W                      | 150 $\Omega$ /300W               |
| E2000-0007S2    | 0.75                        |                                 |                           |                                  |
| E2000-0015S2    | 1.5                         |                                 |                           | 80 $\Omega$ /500W                |
| E2000-0022S2    | 2.2                         |                                 |                           |                                  |
| E2000-0002T2    | 0.2                         | 80                              | 200W                      | 150 $\Omega$ /300W               |
| E2000-0004T2    | 0.4                         |                                 |                           |                                  |
| E2000-0007T2    | 0.75                        |                                 |                           |                                  |
| E2000-0015T2    | 1.5                         |                                 | 200W                      | 80 $\Omega$ /500W                |
| E2000-0022T2    | 2.2                         |                                 |                           |                                  |
| E2000-0030T2    | 3.0                         |                                 |                           |                                  |
| E2000-0040T2    | 4.0                         | 30                              | 400W                      | 30 $\Omega$ /1kW                 |
| E2000-0055T2    | 5.5                         | 30                              | 550W                      |                                  |
| E2000-0075T2    | 7.5                         | 15                              | 1.1kW                     | 15 $\Omega$ /2kW                 |
| E2000-0110T2    | 11                          | 15                              | 1.5kW                     |                                  |
| E2000-0150T2    | 15                          | 15                              | 2.0kW                     |                                  |
| E2000-0185T2    | 18.5                        | 15                              | 2.0kW                     |                                  |
| E2000-0220T2    | 22                          | 15                              | 2.0kW                     |                                  |
| E2000-0300T2    | 30                          | 10                              | 4.0kW                     | 10 $\Omega$ /4kW                 |
| E2000-0370T2    | 37                          | 10                              | 4.0kW                     |                                  |
| E2000-0450T2    | 45                          | 7.5                             | 4.0kW                     | Two 15 $\Omega$ /2kW in parallel |
| E2000-0550T2    | 55                          | 5                               | 7.5kW                     | Two 10 $\Omega$ /4kW in parallel |
| E2000-0750T2    | 75                          | 3                               | 9.0kW                     | 3 $\Omega$ /9kW                  |
| E2000-0007T3    | 0.75                        | 145                             | 80W                       | 300 $\Omega$ /300W               |
| E2000-0015T3    | 1.5                         | 95                              | 150W                      | 150 $\Omega$ /30W                |
| E2000-0022T3    | 2.2                         | 95                              | 250W                      |                                  |
| E2000-0030T3    | 3.0                         | 90                              | 300W                      | 90 $\Omega$ /1.5kW               |
| E2000-0040T3    | 4.0                         | 90                              | 400W                      |                                  |
| E2000-0055T3    | 5.5                         | 90                              | 550W                      |                                  |
| E2000-0075T3    | 7.5                         | 90                              | 750W                      |                                  |
| E2000-0110T3    | 11                          | 50                              | 1.1kW                     | 50 $\Omega$ /1.5kW               |
| E2000-0150T3    | 15                          | 30                              | 1.5kW                     | 30 $\Omega$ /3kW                 |
| E2000-0185T3    | 18.5                        | 30                              | 2.0kW                     |                                  |
| E2000-0220T3    | 22                          | 30                              | 2.2kW                     |                                  |
| E2000-0300T3    | 30                          | 25                              | 3.0kW                     |                                  |
| E2000-0370T3    | 37                          | 25                              | 3.0kW                     |                                  |
| E2000-0450T3    | 45                          | 15                              | 4.0kW                     |                                  |

---

|              |     |    |       |         |
|--------------|-----|----|-------|---------|
| E2000-0550T3 | 55  | 15 | 4.0kW | 15Ω/4kW |
| E2000-0750T3 | 75  | 12 | 6.0kW | 12Ω/6kW |
| E2000-0900T3 | 90  | 8  | 9.0kW | 8Ω/9kW  |
| E2000-1100T3 | 110 | 8  | 9.0kW |         |

**Note: in the occasion of large inertia load, if the braking resistor heat is serious, please adopt the larger power of resistor than recommended resistor.**

## Appendix 5                      Communication Manual

### (Version 1.8)

## I. General

Modbus is a serial and asynchronous communication protocol. Modbus protocol is a general language applied to PLC and other controlling units. This protocol has defined an information structure which can be identified and used by a controlling unit regardless of whatever network they are transmitted.

You can read reference books or ask for the details of MODBUS from manufactures.

Modbus protocol does not require a special interface while a typical physical interface is RS485.

## II. Modbus Protocol

### 2.1 Transmission mode

#### 2.1.1 Format

##### 1) ASCII mode

| Start       | Address             | Function         | Data           |           |     |           | LRC check                 |                             | End              |                     |
|-------------|---------------------|------------------|----------------|-----------|-----|-----------|---------------------------|-----------------------------|------------------|---------------------|
| :<br>(0X3A) | Inverter<br>Address | Function<br>Code | Data<br>Length | Data<br>1 | ... | Data<br>N | High-order<br>byte of LRC | Low-order<br>byte of<br>LRC | Return<br>(0X0D) | Line Feed<br>(0X0A) |

##### 2) RTU mode

| Start       | Address             | Function         | Data   | CRC check                |                           | End         |
|-------------|---------------------|------------------|--------|--------------------------|---------------------------|-------------|
| T1-T2-T3-T4 | Inverter<br>Address | Function<br>Code | N data | Low-order byte<br>of CRC | High-order byte<br>of CRC | T1-T2-T3-T4 |

#### 2.1.2 ASCII Mode

In ASCII mode, one Byte (hexadecimal format) is expressed by two ASCII characters.

For example, 31H (hexadecimal data) includes two ASCII characters '3'(33H)', '1'(31H)'.

Common characters, ASCII characters are shown in the following table:

|                   |     |     |     |     |     |     |     |     |
|-------------------|-----|-----|-----|-----|-----|-----|-----|-----|
| <b>Characters</b> | '0' | '1' | '2' | '3' | '4' | '5' | '6' | '7' |
| <b>ASCII Code</b> | 30H | 31H | 32H | 33H | 34H | 35H | 36H | 37H |
| <b>Characters</b> | '8' | '9' | 'A' | 'B' | 'C' | 'D' | 'E' | 'F' |
| <b>ASCII Code</b> | 38H | 39H | 41H | 42H | 43H | 44H | 45H | 46H |

#### 2.1.3 RTU Mode

In RTU mode, one Byte is expressed by hexadecimal format. For example, 31H is delivered to data packet.

### 2.2 Baud rate

Setting range: 1200, 2400, 4800, 9600, 19200, 38400, 57600

### 2.3 Frame structure:

ASCII mode

| Byte | Function                                                                     |
|------|------------------------------------------------------------------------------|
| 1    | Start Bit (Low Level)                                                        |
| 7    | Data Bit                                                                     |
| 0/1  | Parity Check Bit (None for this bit in case of no checking. Otherwise 1 bit) |
| 1/2  | Stop Bit (1 bit in case of checking, otherwise 2 bits)                       |

## 2) RTU mode

| Byte | Function                                                                     |
|------|------------------------------------------------------------------------------|
| 1    | Start Bit (Low Level)                                                        |
| 8    | Data Bit                                                                     |
| 0/1  | Parity Check Bit (None for this bit in case of no checking. Otherwise 1 bit) |
| 1/2  | Stop Bit (1 bit in case of checking, otherwise 2 bits)                       |

## 2.4 Error Check

### 2.4.1 ASCII mode

Longitudinal Redundancy Check (LRC): It is performed on the ASCII message field contents excluding the 'colon' character that begins the message, and excluding the CRLF pair at the end of the message. The LRC is calculated by adding together successive 8-bit bytes of the message, discarding any carries, and then two's complementing the result.

A procedure for generating an LRC is:

1. Add all bytes in the message, excluding the starting 'colon' and ending CRLF. Add them into an 8-bit field, so that carries will be discarded.
2. Subtract the final field value from FF hex (all 1's), to produce the ones-complement.
3. Add 1 to produce the two's-complement.

### 2.4.2 RTU Mode

Cyclical Redundancy Check (CRC): The CRC field is two bytes, containing a 16-bit binary value. The CRC is started by first preloading a 16-bit register to all 1's. Then a process begins of applying successive 8-bit bytes of the message to the current contents of the register. Only the eight bits of data in each character are used for generating the CRC. Start and stop bits, and the parity bit, do not apply to the CRC.

A procedure for generating a CRC-16 is:

1. Load a 16-bit register with FFFF hex (all 1's). Call this the CRC register.
  2. Exclusive OR the first 8-bit byte of the message with the high-order byte of the 16-bit CRC register, putting the result in the CRC register.
  3. Shift the CRC register one bit to the right (toward the LSB), zero-filling the MSB. Extract and examine the LSB.
  4. (If the LSB was 0): Repeat Step 3 (another shift).
- (If the LSB was 1): Exclusive OR the CRC register with the polynomial value A001 hex (1010 0000 0000 0001).
5. Repeat Steps 3 and 4 until 8 shifts have been performed. When this is done, a complete 8-bit byte will have been processed.

When the CRC is appended to the message, the low-order byte is appended first, followed by the high-order byte.

### 2.4.3 Protocol Converter

It is easy to turn a RTU command into an ASCII command followed by the lists:

- 1) Use the LRC replacing the CRC.
- 2) Transform each byte in RTU command into a corresponding two byte ASCII. For example: transform 0x03 into 0x30, 0x33 (ASCII code for 0 and ASCII code for 3).
- 3) Add a 'colon' (:) character (ASCII 3A hex) at the beginning of the message.
- 4) End with a 'carriage return – line feed' (CRLF) pair (ASCII 0D and 0A hex).

So we will introduce RTU Mode in followed part. If you use ASCII mode, you can use the up lists to convert.

## 2.5 Command Type & Format

### 2.5.1 The listing below shows the function codes.

| code | name                   | description                                                                                        |
|------|------------------------|----------------------------------------------------------------------------------------------------|
| 03   | Read Holding Registers | Read the binary contents of holding registers in the slave.<br>(Less than 10 registers once time ) |
| 06   | Preset Single Register | Preset a value into holding register                                                               |

### 2.5.2 Address and meaning

The part introduces inverter running, inverter status and related parameters setting.

Description of rules of function codes parameters address:

- 1) Use the function code as parameter address

General Series:

High-order byte: 01~0A (hexadecimal)

Low-order byte: 00~50 (max range) (hexadecimal) Function code range of each partition is not the same. The specific range refers to manual.

For example: parameter address of F114 is 010E (hexadecimal).

parameter address of F201 is 0201 (hexadecimal).

For H section, please convert H0 to 43.

For example: the address of H014 is 430E.

**Note: in this situation, it allows to read six function codes and write only one function code. Some function codes can only be checked but cannot be modified; some function codes can neither be checked nor be modified; some function codes cannot be modified in run state; some function codes cannot be modified both in stop and run state.**

**In case parameters of all function codes are changed, the effective range, unit and related instructions shall refer to user manual of related series of inverters. Otherwise, unexpected results may occur.**

- 2) Use different parameters as parameter address

(The above address and parameters descriptions are in hexadecimal format, for example, the decimal digit 4096 is represented by hexadecimal 1000).

### 1. Running status parameters

| Parameters Address | Parameter Description (read only) |
|--------------------|-----------------------------------|
| 1000               | Output frequency                  |
| 1001               | Output voltage                    |
| 1002               | Output current                    |



|      |                                                                                                                                                                                                                                                                                                                                                                                                                                                                                                                                                                                                                                                                                                                                                                                                                                                                                                                                                    |
|------|----------------------------------------------------------------------------------------------------------------------------------------------------------------------------------------------------------------------------------------------------------------------------------------------------------------------------------------------------------------------------------------------------------------------------------------------------------------------------------------------------------------------------------------------------------------------------------------------------------------------------------------------------------------------------------------------------------------------------------------------------------------------------------------------------------------------------------------------------------------------------------------------------------------------------------------------------|
| 1003 | Pole numbers/ control mode, high-order byte is pole numbers, low-order byte is control mode.                                                                                                                                                                                                                                                                                                                                                                                                                                                                                                                                                                                                                                                                                                                                                                                                                                                       |
| 1004 | Bus-line voltage                                                                                                                                                                                                                                                                                                                                                                                                                                                                                                                                                                                                                                                                                                                                                                                                                                                                                                                                   |
| 1005 | Drive ratio/inverter status<br>High-order byte is drive ratio, low-order byte is inverter status<br>Inverter status:<br>0X00: Standby mode                      0X01: Forward running<br>0X02: Reverse running                    0X04: Over-current (OC)<br>0X05: DC over-current (OE)            0X06: Input Phase loss (PF1)<br>0X07: Frequency Over-load (OL1)      0X08: Under-voltage (LU)<br>0X09: Overheat (OH)                    0X0A: Motor overload (OL2)<br>0X0B: Interference (Err)                0X37:CE1<br>0X0D: External Malfunction (ESP)      0X0E: Err3    0X0F: Err2<br>0X11: Err4    0X12: OC1    0X13:PF0<br>0X14: Analog disconnected protection (AErr)<br>0X15: EP3    0X16: under-load (EP)    0X17: PP<br>0X18: Pressure control protection (Np)<br>0X19: PID parameters are set incorrectly (Err5)<br>0X2D: Communication timeout (CE)<br>0X31: Watchdog fault (Err6)    0X34: oPEn fault<br>0X36: STO    0X48: STO1 |
| 1006 | The percent of output torque                                                                                                                                                                                                                                                                                                                                                                                                                                                                                                                                                                                                                                                                                                                                                                                                                                                                                                                       |
| 1007 | Inverter radiator temperature                                                                                                                                                                                                                                                                                                                                                                                                                                                                                                                                                                                                                                                                                                                                                                                                                                                                                                                      |
| 1008 | PID given value                                                                                                                                                                                                                                                                                                                                                                                                                                                                                                                                                                                                                                                                                                                                                                                                                                                                                                                                    |
| 1009 | PID feedback value                                                                                                                                                                                                                                                                                                                                                                                                                                                                                                                                                                                                                                                                                                                                                                                                                                                                                                                                 |
| 100A | Read integer power value                                                                                                                                                                                                                                                                                                                                                                                                                                                                                                                                                                                                                                                                                                                                                                                                                                                                                                                           |
| 100B | DI terminal status: DI1~DI8—bit0—bit7                                                                                                                                                                                                                                                                                                                                                                                                                                                                                                                                                                                                                                                                                                                                                                                                                                                                                                              |
| 100C | Terminal output status :<br>bit0-OUT1    bit1-OUT2    bit2-fault relay                                                                                                                                                                                                                                                                                                                                                                                                                                                                                                                                                                                                                                                                                                                                                                                                                                                                             |
| 100D | AI1: 0~4095    read input analog digital value                                                                                                                                                                                                                                                                                                                                                                                                                                                                                                                                                                                                                                                                                                                                                                                                                                                                                                     |
| 100E | AI2: 0~4095    read input analog digital value                                                                                                                                                                                                                                                                                                                                                                                                                                                                                                                                                                                                                                                                                                                                                                                                                                                                                                     |
| 100F | AI3: 0~4095    read input analog digital value                                                                                                                                                                                                                                                                                                                                                                                                                                                                                                                                                                                                                                                                                                                                                                                                                                                                                                     |
| 1010 | Reserved                                                                                                                                                                                                                                                                                                                                                                                                                                                                                                                                                                                                                                                                                                                                                                                                                                                                                                                                           |
| 1011 | 0~100.00%    the percent of input pulse                                                                                                                                                                                                                                                                                                                                                                                                                                                                                                                                                                                                                                                                                                                                                                                                                                                                                                            |
| 1012 | 0~100.00%    the percent of output pulse                                                                                                                                                                                                                                                                                                                                                                                                                                                                                                                                                                                                                                                                                                                                                                                                                                                                                                           |
| 1013 | Monitoring in which stage speed inverter is.<br>0000 : no function                      0001 : stage speed 1<br>0010 : stage speed 2                    0011 : stage speed 3<br>0100 : stage speed 4                    0101 : stage speed 5<br>0110 : stage speed 6                    0111 : stage speed 7<br>1000 : stage speed 8                    1001 : stage speed 9<br>1010 : stage speed 10                   1011 : stage speed 11<br>1100 : stage speed 12                   1101 : stage speed 13<br>1110 : stage speed 14                   1111 : stage speed 15                                                                                                                                                                                                                                                                                                                                                                    |
| 1014 | Monitoring external counting value                                                                                                                                                                                                                                                                                                                                                                                                                                                                                                                                                                                                                                                                                                                                                                                                                                                                                                                 |
| 1015 | Monitoring analog output percent, AO1    (0~100.00)                                                                                                                                                                                                                                                                                                                                                                                                                                                                                                                                                                                                                                                                                                                                                                                                                                                                                                |

|      |                                                                                                                                                      |
|------|------------------------------------------------------------------------------------------------------------------------------------------------------|
| 1016 | Monitoring analog output percent, AO2 (0~100.00)                                                                                                     |
| 1017 | Monitoring current speed.                                                                                                                            |
| 1018 | Read accurate power value, and correct the power to 1 decimal place.                                                                                 |
| 101A | Output current(when the current is too high, data overflow from 1002)<br>101A: high 16 bits of output current<br>101B: low 16 bits of output current |
| 101B |                                                                                                                                                      |
| 101C | Transmission ratio                                                                                                                                   |
| 101D | Inverter is ready.                                                                                                                                   |

## 2. Control commands

| Parameters Address | Parameters Description (write only)                                                                                                                                                                                                                                                                                                               |
|--------------------|---------------------------------------------------------------------------------------------------------------------------------------------------------------------------------------------------------------------------------------------------------------------------------------------------------------------------------------------------|
| 2000               | Command meaning:<br>0001: Forward running (no parameters)<br>0002: Reverse running (no parameters)<br>0003: Deceleration stop 0004: Free stop<br>0005: Forward jogging start<br>0006: Forward jogging stop<br>0007: Reserved 0008: Run (no directions) 0009: Fault reset<br>000A: Forward jogging stop 000B: Reverse jogging stop<br>000C: Wakeup |
| 2001               | Lock parameters<br>0001: Relieve system locked (remote control locked)<br>0002: Lock remote control (any remote control commands are no valid before unlocking)<br>0003: RAM and eeprom are permitted to be written.<br>0004: Only RAM is permitted to be written, eeprom is prohibited being written.                                            |
| 2002               | AO1 output percent is set by PC/PLC.<br>Setting range: 0~1000<br>Token output analog is 0~100.0%.                                                                                                                                                                                                                                                 |
| 2003               | AO2 output percent is set by PC/PLC.<br>Setting range: 0~1000<br>Token output analog is 0~100.0%.                                                                                                                                                                                                                                                 |
| 2004               | FO output percent is set by PC/PLC.<br>Setting range: 0~1000<br>FO token output pulse is 0~100.0%.                                                                                                                                                                                                                                                |
| 2005               | To control multi-function output terminal:<br>1 means token output is valid.<br>0 means token output is invalid.                                                                                                                                                                                                                                  |
| 2006               |                                                                                                                                                                                                                                                                                                                                                   |
| 2007               |                                                                                                                                                                                                                                                                                                                                                   |
| 2009               |                                                                                                                                                                                                                                                                                                                                                   |

### 3. Illegal Response When Reading Parameters

| Command Description       | Function                               | Data                                                                                                                                  |
|---------------------------|----------------------------------------|---------------------------------------------------------------------------------------------------------------------------------------|
| Slave parameters response | The highest-order byte changes into 1. | Command meaning:<br>0001: Illegal function code<br>0002: Illegal address<br>0003: Illegal data<br>0004: Slave fault <sup>note 2</sup> |

Note 2: Illegal response 0004 appears below two cases:

4. Do not reset inverter when inverter is in the malfunction state.
5. Do not unlock inverter when inverter is in the locked state.

#### 2.5.3 Additional Remarks

##### Expressions during communication process:

Parameter Values of Frequency=actual value X 100 (General Series)  
 Parameter Values of Frequency=actual value X 10 (Medium Frequency Series)  
 Parameter Values of Time=actual value X 10  
 Parameter Values of Current=actual value X 10  
 Parameter Values of Voltage=actual value X 1  
 Parameter Values of Power=actual value X 100  
 Parameter Values of Drive Ratio=actual value X 100  
 Parameter Values of Version No. =actual value X 100

Instruction: Parameter value is the value sent in the data package. Actual value is the actual value of inverter. After PC/PLC receives the parameter value, it will divide the corresponding coefficient to get the actual value.

NOTE: Take no account of radix point of the data in the data package when PC/PLC transmits command to inverter. The valid value is range from 0 to 65535.

### III Function Codes Related to Communication

| Function Code | Function Definition     | Setting Rang                                                                                                                                                                                                                                                            | Mfr's Value |
|---------------|-------------------------|-------------------------------------------------------------------------------------------------------------------------------------------------------------------------------------------------------------------------------------------------------------------------|-------------|
| F200          | Source of start command | 0: Keypad command;<br>1: Terminal command;<br>2: Keypad+Terminal;<br>3:MODBUS;<br>4: Keypad+Terminal+MODBUS                                                                                                                                                             | 4           |
| F201          | Source of stop command  | 0: Keypad command;<br>1: Terminal command;<br>2: Keypad+Terminal;<br>3:MODBUS;<br>4: Keypad+Terminal+MODBUS                                                                                                                                                             | 4           |
| F203          | Main frequency source X | 0: Digital setting memory;<br>1: External analog AI1;<br>2: External analog AI2;<br>3: Pulse input given;<br>4: Stage speed control;<br>5: No memory by digital setting;<br>6:Keypad potentiometer AI3;<br>7: Reserved;<br>8: Reserved;<br>9: PID adjusting; 10: MODBUS | 0           |
| F900          | Inverter Address        | 1~255                                                                                                                                                                                                                                                                   | 1           |

|      |                       |                                                  |   |
|------|-----------------------|--------------------------------------------------|---|
| F901 | Modbus Mode Selection | 1: ASCII mode<br>2: RTU mode<br>3: Remote keypad | 2 |
| F903 | Parity Check          | 0: Invalid 1: Odd 2: Even                        | 0 |
| F904 | Baud Rate             | 0: 1200 1: 2400 2: 4800<br>3: 9600 4: 19200      | 3 |

Please set functions code related to communication consonant with the PLC/PC communication parameters, when inverter communicates with PLC/PC.

## IV Physical Interface

### 4.1 Interface instruction

Communication interface of RS485 is located on the most left of control terminals, marked underneath with A+ and B-

### 4.2 Structure of Field Bus

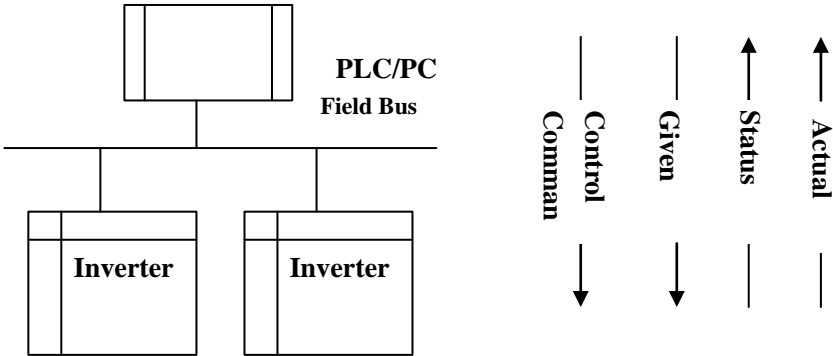

**Connecting Diagram of Field Bus**

RS485 Half-duplex communication mode is adopted for E2000 series inverter. Daisy chain structure is adopted by 485 Bus-line. Do not use 'spur' lines or a star configuration. Reflect signals which are produced by spur lines or star configuration will interfere in 485 communications.

Please note that for the same time in half-duplex connection, only one inverter can have communication with PC/PLC. Should two or more than two inverters upload data at the same time, then bus competition will occur, which will not only lead to communication failure, but higher current to certain elements as well.

### 4.3. Grounding and Terminal

Terminal resistance of 120 Ω will be adopted for terminal of RS485 network, to diminish the reflection of signals. Terminal resistance shall not be used for intermediate network.

No direct grounding shall be allowed for any point of RS485 network. All the equipment in the network shall be well grounded via their own grounding terminal. Please note that grounding wires will not form closed loop in any case.

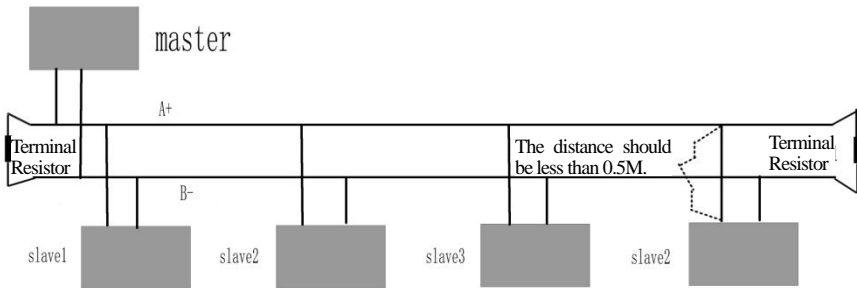

**Connecting Diagram of Terminal Resistance**

Please think over the drive capacity of PC/PLC and the distance between PC/PLC and inverter when wiring. Add a repeaters if drive capacity is not enough.



All wiring connections for installation shall have to be made when the inverter is disconnected from power supply.

## V. Examples

**Eg1:** In RTU mode, change acc time (F114) to 10.0s in NO.01 inverter.

### Query

| Address | Function | Register Address Hi | Register Address Lo | Preset Data Hi | Preset Data Lo | CRC Lo | CRC Hi |
|---------|----------|---------------------|---------------------|----------------|----------------|--------|--------|
| 01      | 06       | 01                  | 0E                  | 00             | 64             | E8     | 1E     |

**Function code F114**

**Value: 10.0S**

### Normal Response

| Address | Function | Register Address Hi | Register Address Lo | Response Data Hi | Response Data Lo | CRC Lo | CRC Hi |
|---------|----------|---------------------|---------------------|------------------|------------------|--------|--------|
| 01      | 06       | 01                  | 0E                  | 00               | 64               | E8     | 1E     |

**Function code F114**

**Normal Response**

### Abnormal Response

| Address | Function | Abnormal code | CRC Lo | CRC Hi |
|---------|----------|---------------|--------|--------|
| 01      | 86       | 04            | 43     | A3     |

**The max value of function code is 1. Slave fault**

**Eg 2:** Read output frequency, output voltage, output current and current rotate speed from N0.2 inverter.

### Host Query

| Address | Function | First Register Address Hi | First Register Address Lo | Register count Hi | Register count L0 | CRC Lo | CRC Hi |
|---------|----------|---------------------------|---------------------------|-------------------|-------------------|--------|--------|
| 02      | 03       | 10                        | 00                        | 00                | 04                | 40     | FA     |

**Communication Parameters Address 1000H**

**Slave Response :**

| Address | Function | Byte Count | Data Hi | Data Lo | Data Hi | Data Lo | Data Hi | Data Lo | Data Hi | Data Lo | Crc Lo | Crc Hi |
|---------|----------|------------|---------|---------|---------|---------|---------|---------|---------|---------|--------|--------|
| 02      | 03       | 08         | 13      | 88      | 01      | 90      | 00      | 3C      | 02      | 00      | 82     | F6     |

**Output Frequency    Output Voltage    Output Current    Numbers of Pole Pairs    Control Mode**

NO.2 Inverter's output frequency is 50.00Hz, output voltage is 380V, output current is 0.6A, numbers of pole pairs are 2 and control mode keypad control.

Eg 3: NO.1 Inverter runs forwardly.

**Host Query:**

| Address | Function | Register Hi | Register Lo | Write status Hi | Write status Lo | CRC Lo | CRC Hi |
|---------|----------|-------------|-------------|-----------------|-----------------|--------|--------|
| 01      | 06       | 20          | 00          | 00              | 01              | 43     | CA     |

**Communication parameters address 2000H**

**Forward running**

**Slave Normal Response:**

| Address | Function | Register Hi | Register Lo | Write status Hi | Write status Lo | CRC Lo | CRC Hi |
|---------|----------|-------------|-------------|-----------------|-----------------|--------|--------|
| 01      | 06       | 20          | 00          | 00              | 01              | 43     | CA     |

**Normal Response**

**Slave Abnormal Response:**

| Address | Function | Abnormal Code | CRC Lo | CRC Hi |
|---------|----------|---------------|--------|--------|
| 01      | 86       | 01            | 83     | A0     |

**The max value of function code is 1.    Illegal function code (assumption)**

Eg4: Read the value of F113, F114 from NO.2 inverter

**Host Query :**

| Address | Function | Register Address Hi | Register Address Lo | Register Count Hi | Register Count L0 | CRC Lo | CRC Hi |
|---------|----------|---------------------|---------------------|-------------------|-------------------|--------|--------|
| 02      | 03       | 01                  | 0D                  | 00                | 02                | 54     | 07     |

**Communication Parameter Address F10DH**

**Numbers of Read Registers**

**Slave Normal Response:**

| Address | Function | Byte count | The first parameters status Hi | The first parameters status Lo | The second parameters status Hi | The second parameters status Lo | CRC Lo | CRC Hi |
|---------|----------|------------|--------------------------------|--------------------------------|---------------------------------|---------------------------------|--------|--------|
|         |          |            |                                |                                |                                 |                                 |        |        |

---

|    |    |    |    |    |    |    |    |    |
|----|----|----|----|----|----|----|----|----|
| 02 | 03 | 04 | 03 | E8 | 00 | 78 | 49 | 61 |
|----|----|----|----|----|----|----|----|----|

The actual value is 10.00.

The actual value is 12.00.

**Slave Abnormal Response:**

| Address | Function Code | Abnormal Code | CRC Lo | CRC Hi |
|---------|---------------|---------------|--------|--------|
| 02      | 83            | 08            | B0     | F6     |

The max value of function code is 1.

Parity check fault

## Appendix 6 Zoom Table of Function Code

### Basic parameters: F100-F160

| Function Code | Function Definition                                             | Setting Range                                                                                                                                     | Mfr's Value               | Change |
|---------------|-----------------------------------------------------------------|---------------------------------------------------------------------------------------------------------------------------------------------------|---------------------------|--------|
| F100          | User's Password                                                 | 0~9999                                                                                                                                            | 0                         | √      |
| F102          | Inverter's Rated Current (A)                                    |                                                                                                                                                   | Subject to inverter model | *      |
| F103          | Inverter Power (kW)                                             |                                                                                                                                                   | Subject to inverter model | *      |
| F104          | Voltage level                                                   |                                                                                                                                                   | Subject to inverter model |        |
| F105          | Software Edition No.                                            | 1.00~10.00                                                                                                                                        | Subject to inverter model | *      |
| F106          | Control mode                                                    | 0: Sensorless vector control (SVC);<br>1: Closed-loop vector control (VC);<br>2: V/F;<br>3: Vector control 1<br>6: PMSM sensorless vector control | 2                         | ×      |
| F107          | Password Valid or Not                                           | 0: invalid; 1: valid                                                                                                                              | 0                         | √      |
| F108          | Setting User's Password                                         | 0~9999                                                                                                                                            | 8                         | √      |
| F109          | Starting Frequency (Hz)                                         | 0.0~10.00Hz                                                                                                                                       | 0.00                      | √      |
| F110          | Holding Time of Starting Frequency (S)                          | 0.0~999.9                                                                                                                                         | 0.0                       | √      |
| F111          | Max Frequency (Hz)                                              | F113~650.0Hz                                                                                                                                      | 50.00                     | √      |
| F112          | Min Frequency (Hz)                                              | 0.00Hz~F113                                                                                                                                       | 0.50                      | √      |
| F113          | Target Frequency (Hz)                                           | F112~F111                                                                                                                                         | 50.00                     | √      |
| F114          | 1 <sup>st</sup> Acceleration Time (S)                           | 0.1~3000                                                                                                                                          | subject to inverter model | √      |
| F115          | 1 <sup>st</sup> Deceleration Time (S)                           | 0.1~3000                                                                                                                                          |                           | √      |
| F116          | 2 <sup>nd</sup> Acceleration Time (S)                           | 0.1~3000                                                                                                                                          |                           | √      |
| F117          | 2 <sup>nd</sup> Deceleration Time (S)                           | 0.1~3000                                                                                                                                          |                           | √      |
| F118          | Turnover Frequency (Hz)                                         | 15.00~650.0                                                                                                                                       | 50.00                     | ×      |
| F119          | Reference of setting accel/decel time                           | 0: 0~50.00Hz<br>1: 0~max frequency                                                                                                                | 0                         | ×      |
| F120          | Forward/Reverse Switchover dead-Time                            | 0.0~3000S                                                                                                                                         | 0.0                       | √      |
| F121          | Reserved                                                        |                                                                                                                                                   |                           |        |
| F122          | Reverse Running Forbidden                                       | 0: invalid; 1: valid                                                                                                                              | 0                         | ×      |
| F123          | Minus frequency is valid in the mode of combined speed control. | 0: Invalid; 1: valid                                                                                                                              | 0                         | ×      |
| F124          | Jogging Frequency                                               | F112~F111                                                                                                                                         | 5.00                      | √      |
| F125          | Jogging Acceleration Time                                       | 0.1~3000S                                                                                                                                         | subject to inverter model | √      |
| F126          | Jogging Deceleration Time                                       | 0.1~3000S                                                                                                                                         |                           | √      |



|      |                              |                                                                                                                                                                                                                                                                                                                                      |              |   |
|------|------------------------------|--------------------------------------------------------------------------------------------------------------------------------------------------------------------------------------------------------------------------------------------------------------------------------------------------------------------------------------|--------------|---|
| F127 | Skip Frequency A             | 0.00~650.0Hz                                                                                                                                                                                                                                                                                                                         | 0.00         | √ |
| F128 | Skip Width A                 | ±2.50Hz                                                                                                                                                                                                                                                                                                                              | 0.00         | √ |
| F129 | Skip Frequency B             | 0.00~650.0Hz                                                                                                                                                                                                                                                                                                                         | 0.00         | √ |
| F130 | Skip Width B                 | ±2.50Hz                                                                                                                                                                                                                                                                                                                              | 0.00         | √ |
| F131 | Running Display Items        | 0—Present output frequency / function code<br>1—Current output rotary speed<br>2—Output current<br>4—Output voltage<br>8—PN voltage<br>16—PID feedback value<br>32—Temperature<br>64—Count values<br>128—Linear speed<br>256—PID given value<br>512—Yarn length<br>1024—Center frequency<br>2048—Output power<br>4096— Output torque | 0+1+2+4+8=15 | √ |
| F132 | Display items of stop        | 0: frequency / function code<br>1: Keypad jogging<br>2: Target rotary speed<br>4: PN voltage<br>8: PID feedback value<br>16: Temperature<br>32: Count values<br>64: PID given value<br>128: Yarn length<br>256: Center frequency<br>512: Setting torque                                                                              | 2+4=6        | √ |
| F133 | Drive Ratio of Driven System | 0.10~200.0                                                                                                                                                                                                                                                                                                                           | 1.0          | √ |
| F134 | Transmission-wheel radius    | 0.001~1.000 (m)                                                                                                                                                                                                                                                                                                                      | 0.001        | √ |
| F135 | User macro                   | 0: Invalid 1: user macro 1<br>2: user macro 2                                                                                                                                                                                                                                                                                        | 0            | × |
| F136 | Slip compensation            | 0~10%                                                                                                                                                                                                                                                                                                                                | 0            | × |

|      |                                                    |                                                                                                                                                   |                           |   |
|------|----------------------------------------------------|---------------------------------------------------------------------------------------------------------------------------------------------------|---------------------------|---|
| F137 | Modes of torque compensation                       | 0: Linear compensation;<br>1: Square compensation;<br>2: User-defined multipoint compensation<br>3: Auto torque compensation<br>4: V/F separation | 3                         | × |
| F138 | Linear compensation                                | 1~20                                                                                                                                              | subject to inverter model | × |
| F139 | Square compensation                                | 1: 1.5; 2: 1.8;<br>3: 1.9; 4: 2.0                                                                                                                 | 1                         | × |
| F140 | Voltage compensation point frequency               | 0.00~F142                                                                                                                                         | 1.00                      | × |
| F141 | Voltage compensation point 1 (%)                   | 0~30                                                                                                                                              | 0                         | × |
| F142 | User-defined frequency point 2                     | F140~F144                                                                                                                                         | 5.00                      | × |
| F143 | User-defined voltage point 2                       | 0~100%                                                                                                                                            | 13                        | × |
| F144 | User-defined frequency point 3                     | F142~F146                                                                                                                                         | 10.00                     | × |
| F145 | User-defined voltage point 3                       | 0~100%                                                                                                                                            | 24                        | × |
| F146 | User-defined frequency point 4                     | F144~F148                                                                                                                                         | 20.00                     | × |
| F147 | User-defined voltage point 4                       | 0~100%                                                                                                                                            | 45                        | × |
| F148 | User-defined frequency point 5                     | F146~F150                                                                                                                                         | 30.00                     | × |
| F149 | User-defined voltage point 5                       | 0~100%                                                                                                                                            | 63                        | × |
| F150 | User-defined frequency point 6                     | F148~F118                                                                                                                                         | 40.00                     | × |
| F151 | User-defined voltage point 6                       | 0~100%                                                                                                                                            | 81                        | × |
| F152 | Output voltage corresponding to turnover frequency | 10~100                                                                                                                                            | 100                       | × |
| F153 | Carrier frequency setting                          | subject to inverter model                                                                                                                         | subject to inverter model | × |
| F154 | Automatic voltage rectification                    | Setting range:<br>0: Invalid 1: Valid<br>2:Invalid during deceleration process                                                                    | 0                         | × |
| F155 | Digital accessory frequency setting                | 0.00~F111                                                                                                                                         | 0                         | × |
| F156 | Digital accessory frequency polarity setting       | 0~1                                                                                                                                               | 0                         | × |
| F157 | Reading accessory frequency                        |                                                                                                                                                   |                           | △ |

|      |                                         |                                                                           |   |   |
|------|-----------------------------------------|---------------------------------------------------------------------------|---|---|
| F158 | Reading accessory frequency polarity    |                                                                           |   | Δ |
| F159 | Random carrier-wave frequency selection | 0: Control speed normally;<br>1: Random carrier-wave frequency            | 0 |   |
| F160 | Reverting to manufacturer values        | 0: Invalid 1: Valid<br>21: revert user macro 1<br>22: revert user macro 2 | 0 | × |

### Running control mode: F200-F230

|      |                              |                                                                                                                                                                                                                                                                         |   |   |
|------|------------------------------|-------------------------------------------------------------------------------------------------------------------------------------------------------------------------------------------------------------------------------------------------------------------------|---|---|
| F200 | Source of start command      | 0: Keypad command;<br>1: Terminal command;<br>2: Keypad+Terminal;<br>3:MODBUS;<br>4: Keypad+Terminal+MODBUS                                                                                                                                                             | 4 | × |
| F201 | Source of stop command       | 0: Keypad command;<br>1: Terminal command;<br>2: Keypad+Terminal;<br>3:MODBUS;<br>4: Keypad+Terminal+MODBUS                                                                                                                                                             | 4 | × |
| F202 | Mode of direction setting    | 0: Forward running locking;<br>1: Reverse running locking;<br>2: Terminal setting<br>3: Keypad setting<br>4: Keypad setting and direction in memory                                                                                                                     | 0 | × |
| F203 | Main frequency source X      | 0: Digital setting memory;<br>1: External analog AI1;<br>2: External analog AI2;<br>3: Pulse input given;<br>4: Stage speed control;<br>5: No memory by digital setting;<br>6:Keypad potentiometer AI3;<br>7: Reserved;<br>8: Reserved;<br>9: PID adjusting; 10: MODBUS | 0 | × |
| F204 | Accessory frequency source Y | 0: Digital setting memory;<br>1: External analog AI1;<br>2: External analog AI2;<br>3: Pulse input given;<br>4: Stage speed control;<br>5: PID adjusting;<br>6: Keypad potentiometer AI3;                                                                               | 0 | × |

|      |                                                              |                                                                                                                                                                                                                           |      |   |
|------|--------------------------------------------------------------|---------------------------------------------------------------------------------------------------------------------------------------------------------------------------------------------------------------------------|------|---|
| F205 | Reference for selecting accessorial frequency source Y range | 0: Relative to max frequency;<br>1: Relative to main frequency X                                                                                                                                                          | 0    | × |
| F206 | Accessorial frequency Y range                                | 0~150                                                                                                                                                                                                                     | 100  | × |
| F207 | Frequency source selecting                                   | 0: X; 1: X+Y;<br>2: X or Y (terminal switchover);<br>3: X or X+Y (terminal switchover);<br>4: Combination of stage speed and analog<br>5: X-Y 6: X+Y-Y <sub>MAX</sub> *50%<br>7: combination 1 of stage speed and digital | 0    | × |
| F208 | Terminal two-line/three-line operation control               | 0: No function;<br>1: Two-line operation mode 1;<br>2: Two-line operation mode 2;<br>3: three-line operation mode 1;<br>4: three-line operation mode 2;<br>5: start/stop controlled by direction pulse                    | 0    | × |
| F209 | Selecting the mode of stopping the motor                     | 0: stop by deceleration time;<br>1: free stop<br>2: Stop by DC braking                                                                                                                                                    | 0    | × |
| F210 | Frequency display accuracy                                   | 0.01~2.00                                                                                                                                                                                                                 | 0.01 | √ |
| F211 | Speed of digital control                                     | 0.01~100.00Hz/S                                                                                                                                                                                                           | 5.00 | √ |
| F212 | Direction memory                                             | 0: Invalid 1: Valid                                                                                                                                                                                                       | 0    | √ |
| F213 | Auto-starting after repowered on                             | 0: invalid; 1: valid                                                                                                                                                                                                      | 0    | √ |
| F214 | Auto-starting after reset                                    | 0: invalid; 1: valid                                                                                                                                                                                                      | 0    | √ |
| F215 | Auto-starting delay time                                     | 0.1~3000.0                                                                                                                                                                                                                | 60.0 | √ |
| F216 | Times of auto-starting in case of repeated faults            | 0~5                                                                                                                                                                                                                       | 0    | √ |
| F217 | Delay time for fault reset                                   | 0.0~10.0                                                                                                                                                                                                                  | 3.0  | √ |
| F218 | Reserved                                                     |                                                                                                                                                                                                                           |      |   |
| F219 | EEPROM write operation                                       | 0:enabled to write<br>1:prohibit writing                                                                                                                                                                                  | 1    | √ |
| F220 | Frequency memory after power-down                            | 0: invalid; 1: valid                                                                                                                                                                                                      | 0    | √ |
| F221 | X+Y-50% (%)                                                  | 0~200                                                                                                                                                                                                                     | 50   | √ |

|      |                                                       |                                    |       |   |
|------|-------------------------------------------------------|------------------------------------|-------|---|
| F222 | count memory selection                                | Setting range: 0: Invalid 1: Valid | 0     | √ |
| F223 | Main frequency coefficient                            | 0.0~100.0                          | 100.0 | √ |
| F224 | When target frequency is lower than Min frequency     | 0: stop<br>1: run at min frequency | 0     | × |
| F234 | switchover frequency during deceleration process (Hz) | 0.00: invalid 0.00~F111            | 0.00  | × |

### Traverse Operating function: F235-F280

|           |                                               |                                                                                                                                                                                                  |       |   |
|-----------|-----------------------------------------------|--------------------------------------------------------------------------------------------------------------------------------------------------------------------------------------------------|-------|---|
| F235      | Traverse operating mode                       | 0: Invalid<br>1: Traverse operating mode 1<br>2: Traverse operating mode 2<br>3: Traverse operating mode 3                                                                                       | 0     | × |
| F236      | Crawl-positioning                             | 0: Disabled 1: Enabled                                                                                                                                                                           | 0     | √ |
| F237      | Traverse signal source                        | 0: Auto start 1: X terminal                                                                                                                                                                      | 0     |   |
| F238      | Stop mode of length arrival                   | 0: Stop the motor at fixed length<br>1: Stop the motor at fixed spindle radius<br>2: Non-stop at fixed length, it indicates full of yarn.<br>3: Fixed radius arrival, it indicates full of yarn. | 0     | × |
| F239      | Traverse memory mode                          | 0: Memory at the status of stop and power off<br>1: Only memory at the status of stop.<br>2: Only memory at the status of power off.<br>3: No memory.                                            | 0     | √ |
| F240      | Preset frequency (Hz)                         | F112~F111                                                                                                                                                                                        | 5.00  | √ |
| F241      | Running time of preset frequency (S)          | 0~3000                                                                                                                                                                                           | 0     | √ |
| F242      | Central frequency (Hz)                        | F243~F111                                                                                                                                                                                        | 25.00 | √ |
| F243      | Lower limit of central frequency (Hz)         | F112~F242                                                                                                                                                                                        | 0.50  | √ |
| F244      | Descending rate of central frequency (Hz / S) | 0.100~65.000                                                                                                                                                                                     | 0.500 | √ |
| F245~F246 | Reserved                                      |                                                                                                                                                                                                  |       |   |
| F247      | Traverse amplitude setting mode               | 0: Relative to max frequency<br>1: Relative to central frequency                                                                                                                                 | 1     | × |
| F248      | Traverse amplitude                            | 0~100.00%                                                                                                                                                                                        | 10.00 | √ |
| F249      | Jump frequency                                | 0~50.00%                                                                                                                                                                                         | 30.00 | √ |
| F250      | Rising time of traverse (S)                   | 0.1~3000                                                                                                                                                                                         | 10.0  | √ |

|           |                                                               |                                                                           |                           |   |
|-----------|---------------------------------------------------------------|---------------------------------------------------------------------------|---------------------------|---|
| F251      | Descending time of traverse (S)                               | 0.1~3000                                                                  | 10.0                      | √ |
| F252      | Crawl-positioning frequency (Hz)                              | F112~F111                                                                 | 3.00                      | √ |
| F253      | Waiting time of crawl-positioning (S)                         | 0.0~3000                                                                  | 5.0                       | √ |
| F254      | Max time of crawl-positioning (S)                             | 0.0~3000                                                                  | 10.0                      | √ |
| F255-F256 | Reserved                                                      |                                                                           |                           |   |
| F257      | Cumulative length (Km)                                        | 0.00~6500                                                                 | 0                         | √ |
| F258      | Actual length (Km)                                            | 0.00~65.00                                                                | 0                         | √ |
| F259      | Setting length (Km)                                           | 0.00~65.00                                                                | 0                         | √ |
| F260      | Pulse numbers of length sensor                                | 0.01~650.0                                                                | 1.00                      | √ |
| F262      | Clear yarn broken signal                                      | 0: stop and refer to yarn broken signal<br>1: refer to yarn broken signal | 0                         | √ |
| F264      | Feedback channel of fixed radius                              | 0: All 1: A12                                                             | 0                         | √ |
| F265      | Fixed-radius display value                                    | 0~10000                                                                   | 1000                      | √ |
| F266      | Output voltage at fixed radius mode (V)                       | 0~10.00                                                                   | 5.00                      | √ |
| F267      | Voltage hysteresis when judging full of yarn signal is clear. | 0~10.00                                                                   | 0                         | √ |
| F269      | DI pre-alarm current                                          | Read only                                                                 | read only                 | △ |
| F270      | DI pre-alarm current threshold                                | 0.01~6.00                                                                 | 0.50                      | √ |
| F271      | DI pre-alarm current delay time                               | 5~60                                                                      | 30                        | √ |
| F272      | Delay time of yarn broken and yarn intertwining (S)           | 0.0~3000.0                                                                | 0.0                       | √ |
| F273-F274 | Reserved                                                      |                                                                           |                           |   |
| F275      | Detect frequency value                                        | F112~F111                                                                 | 25.00                     | √ |
| F276      | Detect frequency width                                        | 0.00~20.00                                                                | 0.50                      | √ |
| F277      | Third Acceleration Time (S)                                   | Setting range:<br>0.1~3000                                                | subject to inverter model | √ |
| F278      | Third Deceleration Time (S)                                   |                                                                           |                           | √ |
| F279      | Fourth Acceleration Time (S)                                  |                                                                           |                           | √ |
| F280      | Fourth Deceleration Time (S)                                  |                                                                           |                           | √ |

### Multifunctional Input and Output Terminals: F300-F330

|      |                                    |                                  |      |   |
|------|------------------------------------|----------------------------------|------|---|
| F300 | Relay token output                 |                                  | 1    | √ |
| F301 | DO1 token output                   |                                  | 14   | √ |
| F302 | DO2 token output                   |                                  | 5    |   |
| F303 | DO output types selection          | 0: level output 1 : pulse output | 0    | √ |
| F304 | S curve beginning stage proportion | 2.0~50.0                         | 30.0 | √ |

|      |                                    |                                                                                                                                                                                                                                                                                                                                                                                                                                                                                                                                                                                                                                                                                                                                                                                                                                                                                                                          |               |   |
|------|------------------------------------|--------------------------------------------------------------------------------------------------------------------------------------------------------------------------------------------------------------------------------------------------------------------------------------------------------------------------------------------------------------------------------------------------------------------------------------------------------------------------------------------------------------------------------------------------------------------------------------------------------------------------------------------------------------------------------------------------------------------------------------------------------------------------------------------------------------------------------------------------------------------------------------------------------------------------|---------------|---|
| F305 | S curve ending stage proportion    | 2.0~50.0                                                                                                                                                                                                                                                                                                                                                                                                                                                                                                                                                                                                                                                                                                                                                                                                                                                                                                                 | 30.0          | √ |
| F306 | Accel/decel mode                   | 0: Straight-line 1: S curve                                                                                                                                                                                                                                                                                                                                                                                                                                                                                                                                                                                                                                                                                                                                                                                                                                                                                              | 0             | × |
| F307 | Characteristic frequency 1         | F112~F111                                                                                                                                                                                                                                                                                                                                                                                                                                                                                                                                                                                                                                                                                                                                                                                                                                                                                                                | 10.00         | √ |
| F308 | Characteristic frequency 2         | F112~F111                                                                                                                                                                                                                                                                                                                                                                                                                                                                                                                                                                                                                                                                                                                                                                                                                                                                                                                | 50.00         | √ |
| F309 | Characteristic frequency width (%) | 0~100                                                                                                                                                                                                                                                                                                                                                                                                                                                                                                                                                                                                                                                                                                                                                                                                                                                                                                                    | 50            | √ |
| F310 | Characteristic current (A)         | 0~5000.0                                                                                                                                                                                                                                                                                                                                                                                                                                                                                                                                                                                                                                                                                                                                                                                                                                                                                                                 | Rated current | √ |
| F311 | Characteristic current width (%)   | 0~100                                                                                                                                                                                                                                                                                                                                                                                                                                                                                                                                                                                                                                                                                                                                                                                                                                                                                                                    | 10            | √ |
| F312 | Frequency arrival threshold (Hz)   | 0.00~5.00                                                                                                                                                                                                                                                                                                                                                                                                                                                                                                                                                                                                                                                                                                                                                                                                                                                                                                                | 0.00          | √ |
| F313 | Count frequency divisions          | 1~65000                                                                                                                                                                                                                                                                                                                                                                                                                                                                                                                                                                                                                                                                                                                                                                                                                                                                                                                  | 1             | √ |
| F314 | Set count value                    | F315~65000                                                                                                                                                                                                                                                                                                                                                                                                                                                                                                                                                                                                                                                                                                                                                                                                                                                                                                               | 1000          | √ |
| F315 | Designated count value             | 1~F314                                                                                                                                                                                                                                                                                                                                                                                                                                                                                                                                                                                                                                                                                                                                                                                                                                                                                                                   | 500           | √ |
| F316 | DI1 terminal function setting      | 0: no function;<br>1: running terminal;<br>2: stop terminal;<br>3: multi-stage speed terminal 1;<br>4: multi-stage speed terminal 2;<br>5: multi-stage speed terminal 3;<br>6: multi-stage speed terminal 4;<br>7: reset terminal;<br>8: free stop terminal;<br>9: external emergency stop terminal;<br>10: acceleration/deceleration forbidden terminal;<br>11: forward run jogging;<br>12: reverse run jogging;<br>13: UP frequency increasing terminal;<br>14: DOWN frequency decreasing terminal;<br>15: "FWD" terminal;<br>16: "REV" terminal;<br>17: three-line type input "X" terminal;<br>18: accel/decel time switchover 1;<br>19: Reserved;<br>20: Switchover between speed and torque<br>21: frequency source switchover terminal;<br>22: Count input terminal;<br>23: Count reset terminal<br>24: clear traverse status<br>25: Traverse operating mode is valid.<br>26: yarn broken<br>27: intertwining yarn | 11            | √ |
| F317 | DI2 terminal function setting      |                                                                                                                                                                                                                                                                                                                                                                                                                                                                                                                                                                                                                                                                                                                                                                                                                                                                                                                          | 9             | √ |
| F318 | DI3 terminal function setting      |                                                                                                                                                                                                                                                                                                                                                                                                                                                                                                                                                                                                                                                                                                                                                                                                                                                                                                                          | 15            | √ |
| F319 | DI4 terminal function setting      |                                                                                                                                                                                                                                                                                                                                                                                                                                                                                                                                                                                                                                                                                                                                                                                                                                                                                                                          | 16            | √ |
| F320 | DI5 terminal function setting      |                                                                                                                                                                                                                                                                                                                                                                                                                                                                                                                                                                                                                                                                                                                                                                                                                                                                                                                          | 7             | √ |
| F321 | DI6 terminal function setting      |                                                                                                                                                                                                                                                                                                                                                                                                                                                                                                                                                                                                                                                                                                                                                                                                                                                                                                                          | 8             | √ |
| F322 | DI7 terminal function setting      |                                                                                                                                                                                                                                                                                                                                                                                                                                                                                                                                                                                                                                                                                                                                                                                                                                                                                                                          | 0             | √ |
| F323 | DI8 terminal function setting      |                                                                                                                                                                                                                                                                                                                                                                                                                                                                                                                                                                                                                                                                                                                                                                                                                                                                                                                          | 0             | √ |

|      |                                        |                                                                                                                                                                                                                                                                                                                                                                                                                                                                                                                                  |           |   |
|------|----------------------------------------|----------------------------------------------------------------------------------------------------------------------------------------------------------------------------------------------------------------------------------------------------------------------------------------------------------------------------------------------------------------------------------------------------------------------------------------------------------------------------------------------------------------------------------|-----------|---|
|      |                                        | 28: crawl-positioning signal<br>29: clear actual yarn length and traverse status<br>30: Water lack signal;<br>31: Signal of water<br>32: Fire pressure switchover;<br>33: Emergency fire control<br>34: Accel / decel switchover 2<br>37: Common-open PTC heat protection<br>38: Common-close PTC heat protection<br>41: DI pre-alarm current enable<br>42: oPEn protection terminal.<br>49: PID paused<br>51: Motor switchover<br>53: Watchdog<br>54: Frequency reset<br>60: Communication timeout 2<br>61: Start-stop terminal |           |   |
| F324 | Free stop terminal logic               | 0: positive logic (valid for low level);                                                                                                                                                                                                                                                                                                                                                                                                                                                                                         | 0         | × |
| F325 | External emergency stop terminal logic | 1: negative logic (valid for high level)                                                                                                                                                                                                                                                                                                                                                                                                                                                                                         | 0         | × |
| F326 | Watchdog time                          | 0.0~3000.0                                                                                                                                                                                                                                                                                                                                                                                                                                                                                                                       | 10.0      | √ |
| F327 | Stop mode                              | 0: Free stop 1: Deceleration to stop                                                                                                                                                                                                                                                                                                                                                                                                                                                                                             | 0         | × |
| F328 | Terminal filter times                  | 1~100                                                                                                                                                                                                                                                                                                                                                                                                                                                                                                                            | 20        | √ |
| F329 | Run command of start terminal          | 0: Valid 1: Invalid                                                                                                                                                                                                                                                                                                                                                                                                                                                                                                              | 0         | √ |
| F330 | Diagnostics of DIX terminal            |                                                                                                                                                                                                                                                                                                                                                                                                                                                                                                                                  |           | √ |
| F331 | Monitoring AI1                         |                                                                                                                                                                                                                                                                                                                                                                                                                                                                                                                                  | Read only |   |
| F332 | Monitoring AI2                         |                                                                                                                                                                                                                                                                                                                                                                                                                                                                                                                                  | Read only |   |
| F333 | Monitoring AI3                         |                                                                                                                                                                                                                                                                                                                                                                                                                                                                                                                                  | Read only |   |
| F335 | Relay output simulation                | Setting range:                                                                                                                                                                                                                                                                                                                                                                                                                                                                                                                   | 0         | × |
| F336 | DO1 output simulation                  | 0: Output active.                                                                                                                                                                                                                                                                                                                                                                                                                                                                                                                | 0         | × |
| F337 | DO2 output simulation                  | 1: Output inactive.                                                                                                                                                                                                                                                                                                                                                                                                                                                                                                              | 0         | × |
| F338 | AO1 output simulation                  | Setting range: 0~4095                                                                                                                                                                                                                                                                                                                                                                                                                                                                                                            | 0         | × |
| F339 | AO2 output simulation                  | Setting range: 0~4095                                                                                                                                                                                                                                                                                                                                                                                                                                                                                                            | 0         | × |
| F340 | Selection of terminal negative logic   | 0: Invalid<br>1: DI1 negative logic<br>2: DI2 negative logic<br>4: DI3 negative logic                                                                                                                                                                                                                                                                                                                                                                                                                                            | 0         | √ |



|      |                            |                                                                                                                                |                     |   |
|------|----------------------------|--------------------------------------------------------------------------------------------------------------------------------|---------------------|---|
|      |                            | 8: DI4 negative logic<br>16: DI5 negative logic<br>32: DI6 negative logic<br>64: DI6 negative logic<br>128: DI8 negative logic |                     |   |
| F343 | Delay time of DI1 ON       | 0.00~99.99                                                                                                                     | 0.00                | √ |
| F344 | Delay time of DI2 ON       |                                                                                                                                | 0.00                | √ |
| F345 | Delay time of DI3 ON       |                                                                                                                                | 0.00                | √ |
| F346 | Delay time of DI4 ON       |                                                                                                                                | 0.00                | √ |
| F347 | Delay time of DI5 ON       |                                                                                                                                | 0.00                | √ |
| F348 | Delay time of DI6 ON       |                                                                                                                                | 0.00                | √ |
| F349 | Delay time of DI7 ON       |                                                                                                                                | 0.00                | √ |
| F350 | Delay time of DI8 ON       |                                                                                                                                | 0.00                | √ |
| F351 | Delay time of DI1 OFF      |                                                                                                                                | 0.00                | √ |
| F352 | Delay time of DI2 OFF      |                                                                                                                                | 0.00                | √ |
| F353 | Delay time of DI3 OFF      |                                                                                                                                | 0.00                | √ |
| F354 | Delay time of DI4 OFF      |                                                                                                                                | 0.00                | √ |
| F355 | Delay time of DI5 OFF      |                                                                                                                                | 0.00                | √ |
| F356 | Delay time of DI6 OFF      |                                                                                                                                | 0.00                | √ |
| F357 | Delay time of DI7 OFF      |                                                                                                                                | 0.00                | √ |
| F358 | Delay time of DI8 OFF      |                                                                                                                                | 0.00                | √ |
| F359 | Stop command priority      |                                                                                                                                | 0: Invalid 1: Valid | 0 |
| F360 | DO terminal negative logic | 0: Invalid<br>1: DO1 negative logic<br>2: DO2 negative logic<br>4: Relay 1                                                     | 0                   | √ |

## Analog Input and Output: F400-F480

|      |                                                    |                                                                                                    |       |   |
|------|----------------------------------------------------|----------------------------------------------------------------------------------------------------|-------|---|
| F400 | Lower limit of AI1 channel input (V)               | 0.00~F402                                                                                          | 0.04  | ○ |
| F401 | Corresponding setting for lower limit of AI1 input | 0.00~2.00                                                                                          | 1.00  | √ |
| F402 | Upper limit of AI1 channel input (V)               | F400~10.00                                                                                         | 10.00 | ○ |
| F403 | Corresponding setting for upper limit of AI1 input | 0.00~2.00                                                                                          | 2.00  | √ |
| F404 | AI1 channel proportional gain K1                   | 0.0~10.0                                                                                           | 1.0   | √ |
| F405 | AI1 filtering time constant (S)                    | 0.01~10.0                                                                                          | 0.10  | √ |
| F406 | Lower limit of AI2 channel input (V)               | 0.00~F408                                                                                          | 0.04  | ○ |
| F407 | Corresponding setting for lower limit of AI2 input | 0.00~2.00                                                                                          | 1.00  | √ |
| F408 | Upper limit of AI2 channel input (V)               | F406~10.00                                                                                         | 10.00 | ○ |
| F409 | Corresponding setting for upper limit of AI2 input | 0.00~2.00                                                                                          | 2.00  | √ |
| F410 | AI2 channel proportional gain K2                   | 0.0~10.0                                                                                           | 1.0   | √ |
| F411 | AI2 filtering time constant                        | 0.01~10.00                                                                                         | 0.10  | √ |
| F412 | Lower limit of AI3 channel input                   | 0.00~F414                                                                                          | 0.05  | ○ |
| F413 | Corresponding setting for lower limit of AI3 input | 0.00~2.00                                                                                          | 1.00  | √ |
| F414 | Upper limit of AI3 channel input                   | F412~10.0                                                                                          | 10.0  | ○ |
| F415 | Corresponding setting for upper limit of AI3 input | 0.00~2.00                                                                                          | 2.00  | √ |
| F416 | AI3 channel proportional gain K1                   | 0.0~10.0                                                                                           | 1.0   | √ |
| F417 | AI3 filtering time constant                        | 0.01~10.00                                                                                         | 0.10  | √ |
| F418 | AI1 channel 0Hz voltage dead zone                  | 0.00~1.00                                                                                          | 0.00  | √ |
| F419 | AI2 channel 0Hz voltage dead zone                  | 0.00~1.00                                                                                          | 0.00  | √ |
| F420 | AI3 channel 0Hz voltage dead zone                  | 0.00~1.00                                                                                          | 0.00  | √ |
| F421 | Panel selection                                    | 0: Local keypad panel<br>1: Remote control keypad panel<br>2: local keypad + remote control keypad | 1     | √ |

|               |                                                                      |                                                                                                                                                                                                                                                                |       |   |
|---------------|----------------------------------------------------------------------|----------------------------------------------------------------------------------------------------------------------------------------------------------------------------------------------------------------------------------------------------------------|-------|---|
| F422          | Potentiometer selection                                              | 0: Potentiometer in local panel<br>1: Potentiometer in remote control panel                                                                                                                                                                                    | 0     | √ |
| F423          | AO1 output range                                                     | 0: 0~5V; 1: 0~10V or 0-20mA                                                                                                                                                                                                                                    | 1     | √ |
| F424          | AO1 lowest corresponding frequency                                   | 0.0~F425                                                                                                                                                                                                                                                       | 0.05  | √ |
| F425          | AO1 highest corresponding frequency                                  | F424~F111                                                                                                                                                                                                                                                      | 50.00 | √ |
| F426          | AO1 output compensation                                              | 0~120                                                                                                                                                                                                                                                          | 100   | √ |
| F427          | AO2 output range                                                     | 0: 0~20mA; 1: 4~20mA                                                                                                                                                                                                                                           | 0     | √ |
| F428          | AO2 lowest corresponding frequency                                   | 0.0~F429                                                                                                                                                                                                                                                       | 0.05  | √ |
| F429          | AO2 highest corresponding frequency                                  | F428~F111                                                                                                                                                                                                                                                      | 50.00 | √ |
| F430          | AO2 output compensation                                              | 0~120%                                                                                                                                                                                                                                                         | 100   | √ |
| F431          | AO1 analog output signal selecting                                   | 0: Running frequency;<br>1: Output current;<br>2: Output voltage;<br>3: AI1 4: AI2<br>5: Input pulse<br>6: Output torque<br>7: Given by PC/PLC<br>8: Target frequency<br>9: Speed<br>10: Output torque 2<br>11: Reserved<br>12: Output power<br>13: DO2 output | 0     | √ |
| F432          | AO2 analog output signal selecting                                   |                                                                                                                                                                                                                                                                | 1     | √ |
| F433          | Corresponding current for full range of external voltmeter           | 0.01~5.00 times of rated current                                                                                                                                                                                                                               | 2.00  | × |
| F434          | Corresponding current for full range of external ammeter             |                                                                                                                                                                                                                                                                | 2.00  | × |
| F435          | Corresponding multiple of rated power for output max analog value    | 0.01~3.00                                                                                                                                                                                                                                                      | 2.00  | × |
| F436          | Corresponding current multiple of rated torque for output max analog | 0.01~3.00                                                                                                                                                                                                                                                      | 3.00  | × |
| F437-<br>F439 | Reserved                                                             |                                                                                                                                                                                                                                                                |       |   |
| F440          | Min frequency of input pulse FI                                      | 0.00~F442                                                                                                                                                                                                                                                      | 0.00  | √ |
| F441          | Corresponding setting of FI min frequency                            | 0.00~F443                                                                                                                                                                                                                                                      | 1.00  | √ |
| F442          | Max frequency of input pulse FI                                      | F440~100.00                                                                                                                                                                                                                                                    | 10.00 | √ |
| F443          | Corresponding setting of FI max frequency                            | Max (1.00, F441) ~2.00                                                                                                                                                                                                                                         | 2.00  | √ |
| F444          | Reserved                                                             |                                                                                                                                                                                                                                                                |       |   |
| F445          | Filtering constant of FI input pulse                                 | 0~100                                                                                                                                                                                                                                                          | 0     | √ |

|               |                                                     |                                                                                                                                                                    |       |   |
|---------------|-----------------------------------------------------|--------------------------------------------------------------------------------------------------------------------------------------------------------------------|-------|---|
| F446          | FI channel 0Hz frequency dead zone                  | 0~F442Hz (Positive-Negative)                                                                                                                                       | 0.00  | √ |
| F447-<br>F448 | Reserved                                            |                                                                                                                                                                    |       |   |
| F449          | Max frequency of output pulse FO                    | 0.00~100.00                                                                                                                                                        | 10.00 | √ |
| F450          | Zero bias coefficient of output pulse frequency (%) | 0.0~100.0                                                                                                                                                          | 0.0   | √ |
| F451          | Frequency gain of output pulse                      | 0.00~10.00                                                                                                                                                         | 1.00  | √ |
| F452          | Reserved                                            |                                                                                                                                                                    |       |   |
| F453          | Output pulse signal                                 | 0: Running frequency<br>1: Output current<br>2: Output voltage<br>3: AI1 4: AI2<br>5: Input pulse<br>6: Output torque<br>7: Given by PC/PLC<br>8: Target frequency | 0     | √ |
| F460          | AI1 channel input mode                              | 0: straight line mode<br>1: folding line mode                                                                                                                      | 0     | × |
| F461          | AI2 channel input mode                              | 0: straight line mode<br>1: folding line mode                                                                                                                      | 0     | × |
| F462          | AI1 insertion point A1 voltage value                | F400~F464                                                                                                                                                          | 2.00  | × |
| F463          | AI1 insertion point A1 setting value                | 0.00~2.00                                                                                                                                                          | 1.20  | × |
| F464          | AI1 insertion point A2 voltage value                | F462~F466                                                                                                                                                          | 5.00  | × |
| F465          | AI1 insertion point A2 setting value                | 0.00~2.00                                                                                                                                                          | 1.50  | × |
| F466          | AI1 insertion point A3 voltage value                | F464~F402                                                                                                                                                          | 8.00  | × |
| F467          | AI1 insertion point A3 setting value                | 0.00~2.00                                                                                                                                                          | 1.80  | × |
| F468          | AI2 insertion point B1 voltage value                | F406~F470                                                                                                                                                          | 2.00  | × |
| F469          | AI2 insertion point B1 setting value                | 0.00~2.00                                                                                                                                                          | 1.20  | × |
| F470          | AI2 insertion point B2 voltage value                | F468~F472                                                                                                                                                          | 5.00  | × |
| F471          | AI2 insertion point B2 setting value                | 0.00~2.00                                                                                                                                                          | 1.50  | × |
| F472          | AI2 insertion point B3 voltage value                | F470~F412                                                                                                                                                          | 8.00  | × |
| F473          | AI2 insertion point B3 setting value                | 0.00~2.00                                                                                                                                                          | 1.80  | × |
| F477          | User-define speed control mode                      | 0: Invalid 1: Valid                                                                                                                                                | 0     | × |
| F478          | Max limit of output frequency                       | F113~F111                                                                                                                                                          | 50.00 | √ |

### Multi-stage Speed Control: F500-F580

|      |                                                               |                                                                                  |   |   |
|------|---------------------------------------------------------------|----------------------------------------------------------------------------------|---|---|
| F500 | Stage speed type                                              | 0: 3-stage speed;<br>1: 15-stage speed;<br>2: Max 8-stage speed auto circulating | 1 | × |
| F501 | Selection of Stage Speed Under Auto-circulation Speed Control | 2~8                                                                              | 7 | √ |

|               |                                                                   |                                                                                       |                           |   |
|---------------|-------------------------------------------------------------------|---------------------------------------------------------------------------------------|---------------------------|---|
| F502          | Selection of Times of Auto- Circulation Speed Control             | 0~9999 (when the value is set to 0, the inverter will carry out infinite circulating) | 0                         | √ |
| F503          | Status after auto circulation running Finished                    | 0: Stop<br>1: Keep running at last stage speed                                        | 0                         | √ |
| F504          | Frequency setting for stage 1 speed                               | F112~F111                                                                             | 5.00                      | √ |
| F505          | Frequency setting for stage 2 speed                               | F112~F111                                                                             | 10.00                     | √ |
| F506          | Frequency setting for stage 3 speed                               | F112~F111                                                                             | 15.00                     | √ |
| F507          | Frequency setting for stage 4 speed                               | F112~F111                                                                             | 20.00                     | √ |
| F508          | Frequency setting for stage 5 speed                               | F112~F111                                                                             | 25.00                     | √ |
| F509          | Frequency setting for stage 6 speed                               | F112~F111                                                                             | 30.00                     | √ |
| F510          | Frequency setting for stage 7 speed                               | F112~F111                                                                             | 35.00                     | √ |
| F511          | Frequency setting for stage 8 speed                               | F112~F111                                                                             | 40.00                     | √ |
| F512          | Frequency setting for stage 9 speed                               | F112~F111                                                                             | 5.00                      | √ |
| F513          | Frequency setting for stage 10 speed                              | F112~F111                                                                             | 10.00                     | √ |
| F514          | Frequency setting for stage 11 speed                              | F112~F111                                                                             | 15.00                     | √ |
| F515          | Frequency setting for stage 12 speed                              | F112~F111                                                                             | 20.00                     | √ |
| F516          | Frequency setting for stage 13 speed                              | F112~F111                                                                             | 25.00                     | √ |
| F517          | Frequency setting for stage 14 speed                              | F112~F111                                                                             | 30.00                     | √ |
| F518          | Frequency setting for stage 15 speed                              | F112~F111                                                                             | 35.00                     | √ |
| F519-<br>F533 | Acceleration time setting for the speeds from Stage 1 to stage 15 | 0.1~3000S                                                                             | Subject to inverter model | √ |
| F534-<br>F548 | Deceleration time setting for the speeds from Stage 1 to stage 15 | 0.1~3000S                                                                             |                           | √ |
| F549-<br>F556 | Running directions of stage speeds from Stage 1 to stage 8        | 0: forward running;<br>1: reverse running                                             | 0                         | √ |
| F557-<br>F564 | Running time of stage speeds from Stage 1 to stage 8              | 0.1~3000S                                                                             | 1.0                       | √ |
| F565-<br>F572 | Stop time after finishing stages from Stage 1 to stage 8.         | 0.0~3000S                                                                             | 0.0                       | √ |
| F573-<br>F579 | Running directions of stage speeds from Stage 9 to stage 15.      | 0: forward running;<br>1: reverse running                                             | 0                         | √ |
| F580          | Stage-speed mode                                                  | 0: Stage speed mode 1<br>1: Stage speed mode 2                                        | 0                         | √ |

### Auxiliary Functions: F600-F677

|      |                                  |                                                                                                                      |      |   |
|------|----------------------------------|----------------------------------------------------------------------------------------------------------------------|------|---|
| F600 | DC Braking Function Selection    | 0: Invalid;<br>1: braking before starting;<br>2: braking during stopping;<br>3: braking during starting and stopping | 0    | √ |
| F601 | Initial Frequency for DC Braking | 0.20~50.00                                                                                                           | 1.00 | √ |

|      |                                                    |                                                                                                                                                                    |                                              |   |
|------|----------------------------------------------------|--------------------------------------------------------------------------------------------------------------------------------------------------------------------|----------------------------------------------|---|
| F602 | DC Braking efficiency before Starting              | 0~250 for 30kW and below                                                                                                                                           | 50                                           | √ |
| F603 | DC Braking efficiency During Stop                  | 30kW<br>0~200 for above 30kW                                                                                                                                       | 100                                          | √ |
| F604 | Braking Lasting Time Before Starting               | 0.0~30.00                                                                                                                                                          | 0.50                                         | √ |
| F605 | Braking Lasting Time During Stopping               | 0.0~30.00                                                                                                                                                          | 0.50                                         | √ |
| F607 | Selection of Stalling Adjusting Function           | Setting range:<br>0~2:Reserved<br>3: Voltage/current control<br>4: Voltage control<br>5: Current control                                                           | 3                                            | √ |
| F608 | Stalling Current Adjusting (%)                     | 25~FC49                                                                                                                                                            | 160                                          | √ |
| F609 | Stalling Voltage Adjusting (%)                     | 110~200                                                                                                                                                            | Mfr's value:<br>1-phase: 130<br>3-phase: 140 | √ |
| F610 | Stalling Protection Judging Time (S)               | 0.0~3000.0                                                                                                                                                         | 60.0                                         | √ |
| F611 | Dynamic Braking threshold (V)                      | T3: 600~2000<br>S2/T2: 320~2000                                                                                                                                    | Subject to inverter model                    | △ |
| F612 | Dynamic braking duty ratio (%)                     | 0~100                                                                                                                                                              | 100                                          | × |
| F613 | Speed track                                        | 0: invalid 1: valid<br>2: valid at the first time                                                                                                                  | 0                                            | × |
| F614 | Speed track mode                                   | Setting range:<br>0: Speed track from frequency memory<br>1: Speed track from zero<br>2: Speed track from max frequency                                            | 0                                            | × |
| F615 | Speed track rate                                   | 1~100                                                                                                                                                              | 20                                           | × |
| F618 | Delay time of speed track (S)                      | 0.5~60.0                                                                                                                                                           | 1.5                                          | × |
| F620 | Brake delay turn-off time                          | 0.0 (brake not closed when stop)<br>0.1~3000                                                                                                                       | 5.0                                          | √ |
| F638 | Parameters copy enabled                            | 0: Copy forbidden<br>1: Parameters download 1 (voltage level and power are totally same)<br>2: Parameters download 2 (without considering voltage level and power) | 1                                            | × |
| F639 | Parameters copy code                               | 2000~2999                                                                                                                                                          | Subject to version of software               | △ |
| F640 | Parameter copy type                                | 0: Copy all parameters<br>1: Copy parameters (except motor parameters from F801 to F810/F844)                                                                      | 1                                            | × |
| F641 | Inhibition of current oscillation at low frequency | 0: Invalid 1: Valid                                                                                                                                                | Subject to inverter model                    |   |

|      |                             |                                                                                                                                                                                                                                                                                                                                                                                                                                                                                                                                                                                                                                                                                                                                                                                   |   |   |
|------|-----------------------------|-----------------------------------------------------------------------------------------------------------------------------------------------------------------------------------------------------------------------------------------------------------------------------------------------------------------------------------------------------------------------------------------------------------------------------------------------------------------------------------------------------------------------------------------------------------------------------------------------------------------------------------------------------------------------------------------------------------------------------------------------------------------------------------|---|---|
| F643 | Multi-functional key        | Setting range:<br>0: Invalid<br>1: FWD jogging<br>2: REV jogging<br>3: Switchover between local/remote<br>4. Reverse run control                                                                                                                                                                                                                                                                                                                                                                                                                                                                                                                                                                                                                                                  | 0 | × |
| F644 | Keypad copy enabled         | Setting range: 0: Invalid<br>1: current macro parameter upload<br>2: current macro parameter download<br>3: user macro 1 upload<br>4: user macro 1 download<br>5: user macro 2 upload<br>6: user macro 2 download                                                                                                                                                                                                                                                                                                                                                                                                                                                                                                                                                                 | 0 | × |
| F645 | Status parameters selection | 0: Current running frequency<br>1: Current rotate speed<br>2: Target rotate speed<br>3: Output current<br>4: Output voltage<br>5: PN voltage<br>6: PID setting value<br>7: PID feedback value<br>8: Radiator temperature<br>9: Count value<br>10: Linear speed<br>11: Main frequency setting channel<br>12: Main frequency<br>13: Auxiliary frequency setting channel<br>14: Auxiliary frequency<br>15: Target frequency<br>16: Reserved<br>17: Output torque<br>18: Setting torque<br>19: Motor power<br>20: Output power<br>21: Frequency status<br>22: DI terminal status<br>23: Output terminal status<br>24: Current stage of multi-stage speed<br>25: AI1 input value<br>26: AI2 input value<br>27, 28: Reserved<br>29: Pulse input frequency<br>30: Pulse output frequency | 0 | √ |

|      |                                                       |                                                                                                       |                           |    |
|------|-------------------------------------------------------|-------------------------------------------------------------------------------------------------------|---------------------------|----|
|      |                                                       | 31: AO1 output percentage<br>32: AO2 output percentage<br>33: Power-on time                           |                           |    |
| F646 | Backlight time of LCD (S)                             | 0~100                                                                                                 | 100                       | √  |
| F647 | Language selection                                    | 0: Chinese 1: English<br>2: Deutsch                                                                   | 0                         | √○ |
| F649 | Keypad selection                                      | 0: Automatic identification<br>1: LED remote keypad<br>2: LCD remote keypad                           | 0                         | √○ |
| F657 | Instantaneous power failure selection                 | 0: Invalid<br>1: non-stop after power failure<br>2: decelerate to stop after power failure            | 0                         | ×  |
| F658 | Voltage rally acceleration time                       | 0.0~3000s<br>0.0: F114                                                                                | 0.0                       | √  |
| F659 | Voltage rally deceleration time                       | 0.0~3000s<br>0.0: F115                                                                                | 0.0                       | √  |
| F660 | Action judging voltage at instantaneous power failure | 200~F661                                                                                              | Subject to inverter model | ×○ |
| F661 | Action stop voltage at instantaneous power failure    | F660~1400                                                                                             | Subject to inverter model | ×○ |
| F662 | Instantaneous voltage recovery judging time(s)        | 0.00~10.00                                                                                            | 0.30                      | √  |
| F663 | Instantaneous proportion coefficient Kp               | 0.00~10.00                                                                                            | 0.25                      | √  |
| F664 | instantaneous integral coefficient Ki                 | 0.00~10.00                                                                                            | 0.30                      | √  |
| F670 | Voltage-limit current-limit adjustment coefficient    | 0.01~10.00                                                                                            | 2.00                      | √  |
| F671 | voltage source for V/F separation                     | 0: F672 1: AI1 2: AI2 3: AI3<br>4: Communication setting<br>5: pulse setting 6: PID<br>7~10: reserved | 0                         | ×  |
| F672 | Voltage digital setting for V/F separation            | 0.00~100.00                                                                                           | 100.00                    | √  |
| F673 | Lower limit of voltage at V/F separation (%)          | 0.00~F674                                                                                             | 0.00                      | ×  |
| F674 | Upper limit of voltage at V/F separation (%)          | F673~100.00                                                                                           | 100.00                    | ×  |
| F675 | Voltage rise time of V/F separation (S)               | 0.0~3000.0                                                                                            | 5.0                       | √  |
| F676 | Voltage rise time of V/F separation (S)               | 0.0~3000.0                                                                                            | 5.0                       | √  |



|      |                             |                                                                                                                                             |   |   |
|------|-----------------------------|---------------------------------------------------------------------------------------------------------------------------------------------|---|---|
| F677 | Stop mode at V/F separation | 0: voltage and frequency declines to 0 according to respective time.<br>1: Voltage declines to 0 first<br>2: frequency declines to 0 first. | 0 | × |
|------|-----------------------------|---------------------------------------------------------------------------------------------------------------------------------------------|---|---|

### Timing Control and Protection: F700-F760

|      |                                                           |                                                                                                                                                                                                                                                                                                                                                                                                                                                                                                                                                                              |     |   |
|------|-----------------------------------------------------------|------------------------------------------------------------------------------------------------------------------------------------------------------------------------------------------------------------------------------------------------------------------------------------------------------------------------------------------------------------------------------------------------------------------------------------------------------------------------------------------------------------------------------------------------------------------------------|-----|---|
| F700 | Selection of terminal free stop mode                      | 0: free stop immediately;<br>1: delayed free stop                                                                                                                                                                                                                                                                                                                                                                                                                                                                                                                            | 0   | √ |
| F701 | Delay time for free stop and programmable terminal action | 0.0~60.0s                                                                                                                                                                                                                                                                                                                                                                                                                                                                                                                                                                    | 0.0 | √ |
| F702 | Fan control mode                                          | 0:controlled by temperature<br>1: Running when inverter is powered on<br>2: Controlled by running status                                                                                                                                                                                                                                                                                                                                                                                                                                                                     | 2   | × |
| F704 | Inverter Overloading pre-alarm Coefficient (%)            | 50~100                                                                                                                                                                                                                                                                                                                                                                                                                                                                                                                                                                       | 80  |   |
| F705 | Overloading adjusting gains                               | 50~100                                                                                                                                                                                                                                                                                                                                                                                                                                                                                                                                                                       | 80  | × |
| F706 | Inverter Overloading coefficient%                         | 120~190                                                                                                                                                                                                                                                                                                                                                                                                                                                                                                                                                                      | 150 | × |
| F707 | Motor Overloading coefficient %                           | 20~100                                                                                                                                                                                                                                                                                                                                                                                                                                                                                                                                                                       | 100 | × |
| F708 | Record of The Latest Malfunction Type                     | Setting range:<br>2: Over current (OC)<br>3: over voltage (OE)<br>4: input phase loss (PF1)<br>5: inverter overload (OL1)<br>6: under voltage (LU)<br>7: overheat (OH)<br>8: motor overload (OL2)<br>11: external malfunction (ESP)<br>13. studying parameters without motor (Err2)<br>16: Over current 1 (OC1)<br>17: output phase loss (PF0)<br>18: Aerr analog disconnected<br>20: EP/EP2/EP3 under-load<br>22: nP pressure control<br>23: Err5 PID parameters are set wrong<br>45: Communication timeout (CE)<br>46: Speed track fault (FL)<br>49: Watchdog fault (Err6) |     | △ |
| F709 | Record of Malfunction Type for Last but One               |                                                                                                                                                                                                                                                                                                                                                                                                                                                                                                                                                                              |     | △ |
| F710 | Record of Malfunction Type for Last but Two               |                                                                                                                                                                                                                                                                                                                                                                                                                                                                                                                                                                              |     | △ |
| F711 | Fault Frequency of The Latest Malfunction                 |                                                                                                                                                                                                                                                                                                                                                                                                                                                                                                                                                                              |     | △ |
| F712 | Fault Current of The Latest Malfunction                   |                                                                                                                                                                                                                                                                                                                                                                                                                                                                                                                                                                              |     | △ |
| F713 | Fault PN Voltage of The Latest                            |                                                                                                                                                                                                                                                                                                                                                                                                                                                                                                                                                                              |     | △ |

|      |                                                 |                                                                                                                                          |                           |    |
|------|-------------------------------------------------|------------------------------------------------------------------------------------------------------------------------------------------|---------------------------|----|
|      | Malfuncon                                       |                                                                                                                                          |                           |    |
| F714 | Fault Frequency of Last Malfuncon but One       |                                                                                                                                          |                           | △  |
| F715 | Fault Current of Last Malfuncon but             |                                                                                                                                          |                           | △  |
| F716 | Fault PN Voltage of Last Malfuncon              |                                                                                                                                          |                           | △  |
| F717 | Fault Frequency of Last Malfuncon               |                                                                                                                                          |                           | △  |
| F718 | Fault Current of Last Malfuncon but             |                                                                                                                                          |                           | △  |
| F719 | Fault PN Voltage of Last Malfuncon              |                                                                                                                                          |                           | △  |
| F720 | Record of overcurrent protection fault          |                                                                                                                                          |                           | △  |
| F721 | Record of overvoltage protection fault          |                                                                                                                                          |                           | △  |
| F722 | Record of overheat protection fault             |                                                                                                                                          |                           | △  |
| F723 | Record of overload protection fault             |                                                                                                                                          |                           | △  |
| F724 | Input phase loss                                | 0: invalid; 1: valid                                                                                                                     | S2: 0 T2/T3:1             | ×  |
| F725 | Under-voltage protection                        | 0: reset manually<br>1: reset automatically                                                                                              | 2                         | ×  |
| F726 | Overheat                                        | 0: invalid; 1: valid                                                                                                                     | 1                         | ×  |
| F727 | Output phase loss                               | 0: invalid; 1: valid                                                                                                                     | 1                         | ×  |
| F728 | Input phase loss filtering constant             | 0.1~60.0                                                                                                                                 | 5                         | √  |
| F729 | Under-voltage filtering constant                | 0.1~60.0                                                                                                                                 | 5                         | √  |
| F730 | Overheat protection filtering constant          | 0.1~60.0                                                                                                                                 | 5.0                       | √  |
| F732 | Under-voltage protection voltage threshold (V)  | T2/S2: 120~450<br>T3: 300~450                                                                                                            | Subject to inverter model | ○  |
| F737 | Over-current 1 protection                       | 0: Invalid 1:Valid                                                                                                                       | 1                         |    |
| F738 | Over-current 1 protection coefficient           | 0.50~3.00                                                                                                                                | 2.50                      |    |
| F739 | Over-current 1 protection record                |                                                                                                                                          |                           | △  |
| F741 | Analog disconnected protection                  | 0: Invalid<br>1: Stop and AErr displays.<br>2: Stop and AErr is not displayed.<br>3: Inverter runs at the min frequency.<br>4: Reserved. | 0                         | √  |
| F742 | Threshold of analog disconnected protection (%) | 1~100                                                                                                                                    | 50                        | ○  |
| F743 | Filtering constant of checking STO              | 0.1~10.0                                                                                                                                 | 0.5                       | √  |
| F745 | Threshold of pre-alarm overheat                 | 0~100                                                                                                                                    | 80                        | √○ |
| F746 | Carrier frequency auto-adjusting threshold      | 60~100                                                                                                                                   | 75                        | √○ |
| F747 | Carrier frequency auto-adjusting                | 0: Invalid 1: Valid                                                                                                                      | 1                         | √  |

|      |                                        |                                                |     |   |
|------|----------------------------------------|------------------------------------------------|-----|---|
| F751 | Instantaneous stop pretreatment enable | 0: Invalid 1: Valid                            | 0   | √ |
| F752 | Overload quitting coefficient          | 0.1~20.0                                       | 1.0 | √ |
| F753 | Selection of overload protection       | 0: Normal motor<br>1: variable frequency motor | 1   | × |
| F754 | Zero-current threshold (%)             | 0~200                                          | 5   | × |
| F755 | Duration time of zero-current          | 0~60                                           | 0.5 | √ |
| F759 | Carrier-frequency ratio                | 3~15                                           | 7   | × |
| F760 | Grounding protection                   | 0: Invalid 1: Valid                            | 0   | * |
| F761 | Switchover mode of FWD/REV             | 0: At zero 2: at start frequency               | 0   | × |
| F770 | Auxiliary version No.                  |                                                |     | Δ |

### Motor parameters: F800-F880

|      |                              |                                                                                            |                           |   |
|------|------------------------------|--------------------------------------------------------------------------------------------|---------------------------|---|
| F800 | Motor's parameters selection | Setting range:<br>0: Invalid;<br>1: Rotating tuning.;<br>2: Stationary tuning              | 0                         | × |
| F801 | Rated power                  | 0.1~1000.0                                                                                 |                           | × |
| F802 | Rated voltage                | 1~1300                                                                                     |                           | × |
| F803 | Rated current                | 0.2~6553.5                                                                                 |                           | × |
| F804 | Number of motor poles        | 2~100                                                                                      | 4                         | × |
| F805 | Rated rotary speed           | 1~39000                                                                                    |                           | × |
| F806 | Stator resistance            | 0.001~65.53Ω (for 15kw and below 15kw)<br>0.1~6553mΩ (For above 15kw)                      | Subject to inverter model | × |
| F807 | Rotor resistance             | 0.001~65.53Ω (for 15kw and below 15kw)<br>0.1~6553mΩ (For above 15kw)                      | Subject to inverter model | × |
| F808 | Leakage inductance           | Setting range:<br>0.01~655.3mH (for 15kw and below 15kw)<br>0.001~65.53mH (for above 15kw) | Subject to inverter model | × |
| F809 | Mutual inductance            | Setting range:<br>0.1~6553mH (for 15kw and below 15kw)<br>0.01~655.3mH (for above 15 kw)   | Subject to inverter model | × |
| F810 | Motor rated frequency        | 1.00~650.00                                                                                | 50.00                     | × |

|      |                                              |                                              |                           |    |
|------|----------------------------------------------|----------------------------------------------|---------------------------|----|
| F811 | Carrier frequency switchover point (Hz)      | 0.00~20.00                                   | 8.00                      | √  |
| F812 | Pre-exciting time (S)                        | 0.00~30.00                                   | 0.10                      | √  |
| F813 | Rotary speed loop KP1                        | 1~100                                        | 30                        | √  |
| F814 | Rotary speed loop KI1                        | 0.01~10.00                                   | 0.50                      | √  |
| F815 | Rotary speed loop KP2                        | 1~100                                        | Subject to inverter model | √  |
| F816 | Rotary speed loop KI2                        | 0.01~10.00                                   | 1.00                      | √  |
| F817 | PID switching frequency 1                    | 0~F818                                       | 5.00                      | √  |
| F818 | PID switching frequency 2                    | F817~F111                                    | 10.00                     | √  |
| F819 | Slip coefficient                             | 50~200                                       | 100                       | √  |
| F820 | Filtering coefficient of speed loop          | 0~100                                        | 0                         | √  |
| F822 | Upper limit of speed control torque          | 0.0~250.0                                    | 200                       |    |
| F844 | Motor current without load                   | 0.1~F803                                     | Subject to model          | ×○ |
| F847 | Encoder disconnection detection time(s)      | 0.1~10.0                                     | 2.0                       | ×  |
| F850 | Detection threshold of encoder disconnection | 5~100                                        | 30                        | ×  |
| F851 | Encoder resolution                           | 1~9999                                       | 1000                      | ×○ |
| F854 | Encoder phase sequence                       | 0: forward direction<br>1: reverse direction | 0                         | ×○ |
| F866 | Static position identification               | 0: Invalid 1: Valid                          | 0                         | ×  |
| F867 | Position identification current              | 0~30                                         | 10                        | ×  |
| F868 | Position identification frequency            | 2000~16000                                   | 10000                     | ×  |
| F870 | PMSM back electromotive force (mV/rpm)       | 0.1~6553.0 (valid value between lines)       | 100.0                     | ×○ |
| F871 | PMSM D-axis inductance (mH)                  | 0.01~655.35                                  | 5.00                      | ×○ |
| F872 | PMSM Q-axis inductance (mH)                  | 0.01~655.35                                  | 7.00                      | ×○ |
| F873 | PMSM stator resistance (Ω) (phase resistor)  | 0.001~65.000                                 | 0.500                     | ×○ |
| F874 | Position identification times                | 0~1000                                       | 0                         | ×  |
| F875 | Position identification angle compensation   | 0.0~100.0                                    | 20.0                      | ×  |

|      |                                                                       |            |      |    |
|------|-----------------------------------------------------------------------|------------|------|----|
| F876 | PMSM injection current without load (%)                               | 0.0~100.0  | 20.0 | ×○ |
| F877 | PMSM injection current compensation without load (%)                  | 0.0~50.0   | 0.0  | ×○ |
| F878 | PMSM cut-off point of injection current compensation without load (%) | 0.0~50.0   | 10.0 | ×○ |
| F879 | PMSM injection current with heavy load (%)                            | 0.0~100.0  | 0.0  | ×○ |
| F880 | PMSM PCE detection time (S)                                           | 0.0~10.0 S | 0.2  | ×○ |

### Communication parameter: F900-F930

|      |                                     |                                                                                                  |     |    |
|------|-------------------------------------|--------------------------------------------------------------------------------------------------|-----|----|
| F900 | Communication Address               | 1~255: single inverter address<br>0: broadcast address                                           | 1   | √  |
| F901 | Communication Mode                  | 1: ASCII 2: RTU<br>3: Remote keypad                                                              | 2   | √○ |
| F902 | Stop bits                           | 1~2                                                                                              | 2   | √  |
| F903 | Parity Check                        | 0: Invalid 1: Odd 2: Even                                                                        | 0   | √  |
| F904 | Baud Rate                           | 0: 1200; 1: 2400; 2: 4800;<br>3: 9600; 4: 19200 5: 38400<br>6: 57600                             | 3   | √  |
| F905 | Communication timeout period (S)    | 0.0~3000.0                                                                                       | 0.0 | √  |
| F907 | Time 2 of communication timeout (S) | 0.0~3000.0                                                                                       | 0.0 | √  |
| F911 | Point-point communication selection | 0:Disabled 1:Enabled                                                                             | 0   | ×  |
| F912 | Master and slave selection          | 0:Master 1:Slave                                                                                 | 0   | ×  |
| F913 | Running command of slave            | 0:Slave not following running commands of master<br>1:Slave following running commands of master | 1   | ×  |

|      |                                          |                                                                                                                                                                                        |        |   |
|------|------------------------------------------|----------------------------------------------------------------------------------------------------------------------------------------------------------------------------------------|--------|---|
| F914 | Fault information of slave               | Ones: slave fault information<br>0: Not sending fault information<br>1: Sending fault information<br>Tens: master's reaction when it loses slave's response<br>0: No reaction 1: Alarm | 01     | √ |
| F915 | Master action when slave failed          | 0: continue running<br>1: free stop<br>2: Deceleration to stop                                                                                                                         | 1      | √ |
| F916 | Slave action when master stops           | 1: Free stop<br>2: Deceleration to stop                                                                                                                                                | 1      | √ |
| F917 | Slave following master command selection | 0: given torque(torque)<br>1: given frequency 1(Droop)<br>2: given frequency 2 (Droop)                                                                                                 | 0      | × |
| F918 | Zero offset of received data (torque)    | 0~200.00                                                                                                                                                                               | 100.00 | √ |
| F919 | Gain of received data(torque)            | 0.00~10.00                                                                                                                                                                             | 1.000  | √ |
| F920 | Zero offset of received data (frequency) | 0~200.00                                                                                                                                                                               | 100.00 | √ |
| F921 | Gain of received data(frequency)         | 0.00~10.00                                                                                                                                                                             | 1.000  | √ |
| F922 | window                                   | 0.00~10.00                                                                                                                                                                             | 0.50   | √ |
| F923 | Droop control                            | 0.0~30.0                                                                                                                                                                               | 0.00   | √ |
| F924 | Time of communication timeout (S)        | 0.0~3000.0                                                                                                                                                                             | 0.0    | √ |
| F925 | Master sending data interval (S)         | 0.000~1.000                                                                                                                                                                            | 0.0    | √ |
| F926 | CAN baud rate (kbps)                     | 0:20 1:50 2:100<br>3:125 4: 250 5:500<br>6:1000                                                                                                                                        | 6      | √ |
| F928 | BACnet address                           | 0~127                                                                                                                                                                                  | 1      | √ |
| F929 | BACnet baud rate (bps)                   | 0:9600 1: 19200 2: 38400<br>3:76800                                                                                                                                                    | 1      | √ |
| F930 | Keypad disconnected protection(s)        | 0~10 0: Invalid                                                                                                                                                                        | 0      | √ |

**PID parameters: FA00-FA80**

|      |                                            |                                                                                                                            |       |   |
|------|--------------------------------------------|----------------------------------------------------------------------------------------------------------------------------|-------|---|
| FA00 | Water supply mode                          | 0: Single pump (PID control mode)<br>1: Fixed mode<br>2: Timing interchanging                                              | 0     | × |
| FA01 | PID adjusting target given source          | 0: FA04 1: AI1 2: AI2<br>3: AI3 (Potentiometer on the keypad)<br>4: FI (pulse frequency input)                             | 0     | × |
| FA02 | PID adjusting feedback given source        | 1: AI1 2: AI2<br>3: FI (pulse frequency input)<br>4: reserved<br>5: Running current<br>6: Output power<br>7: Output torque | 1     | √ |
| FA03 | Max limit of PID adjusting (%)             | FA04~100.0                                                                                                                 | 100.0 | √ |
| FA04 | Digital setting value of PID adjusting (%) | FA05~FA03                                                                                                                  | 50.0  | √ |
| FA05 | Min limit of PID adjusting (%)             | 0.0~FA04                                                                                                                   | 0.0   | √ |
| FA06 | PID polarity                               | 0: Positive feedback<br>1: Negative feedback                                                                               | 1     | × |
| FA07 | Dormancy function selection                | 0: Valid 1: Invalid                                                                                                        | 1     | × |
| FA09 | Min frequency of PID adjusting (Hz)        | Max(F112, 0.1)~F111                                                                                                        | 5.00  | √ |
| FA10 | Dormancy delay time (S)                    | 0~500.0                                                                                                                    | 15.0  | √ |
| FA11 | Wake delay time (S)                        | 0.0~3000                                                                                                                   | 3.0   | √ |
| FA12 | PID max frequency(Hz)                      | FA09~F111                                                                                                                  | 50.00 | √ |
| FA18 | Whether PID adjusting target is changed    | 0: Invalid 1: Valid                                                                                                        | 1     | × |
| FA19 | Proportion Gain P                          | 0.00~10.00                                                                                                                 | 0.30  | √ |
| FA20 | Integration time I (S)                     | 0.0~100.0                                                                                                                  | 0.3   | √ |
| FA21 | Differential time D (S)                    | 0.0~10.0                                                                                                                   | 0.0   | √ |
| FA22 | PID sampling period (S)                    | 1~500                                                                                                                      | 5     | √ |
| FA23 | PID negative frequency output selection    | 0: Invalid 1: Valid                                                                                                        | 0     | √ |
| FA24 | Switching Timing unit setting              | 0: hour 1: minute                                                                                                          | 0     | × |
| FA25 | Switching Timing Setting                   | 1~9999                                                                                                                     | 100   | × |
| FA26 | Under-load protection mode                 | 0: No protection<br>1: Protection by contactor<br>2: Protection by PID<br>3: Protection by current                         | 0     | × |

|      |                                                   |                                                                      |       |    |
|------|---------------------------------------------------|----------------------------------------------------------------------|-------|----|
| FA27 | Current threshold of under-load protection (%)    | 10~150                                                               | 80    | √  |
| FA28 | Waking time after protection (min)                | 1~3000                                                               | 60    | √  |
| FA29 | PID dead time (%)                                 | 0.0~10.0                                                             | 2.0   | √  |
| FA30 | Running Interval of restarting converter pump (S) | 2.0~999.9s                                                           | 20.0  | √  |
| FA31 | Delay time of starting general pumps (S)          | 0.1~999.9s                                                           | 30.0  | √  |
| FA32 | Delay time of stopping general pumps (S)          | 0.1~999.9s                                                           | 30.0  | √  |
| FA33 | stop mode when constant pressure water supply     | 0: free stop<br>1: deceleration to stop                              | 0     | ×  |
| FA36 | Whether No.1 relay is started                     | 0: Stopped 1: Started                                                | 0     | ×  |
| FA37 | Whether No.2 relay is started                     | 0: Stopped 1: Started                                                | 0     | ×  |
| FA38 | Proportion gain Kp2                               | 0.00~10.00                                                           | 0.30  | √  |
| FA39 | Integration time Ki2(S)                           | 0.1~100.0                                                            | 0.3   | √  |
| FA40 | Differential time Kd2(S)                          | 0.0~10.0                                                             | 0.0   | √  |
| FA41 | PI parameter switchover type                      | 0: no switchover<br>1: reserved<br>2: Auto switchover<br>3: reserved | 0     | ×  |
| FA42 | Switchover error 1                                | FA05~FA43                                                            | 0.0   | √  |
| FA43 | Switchover error 2                                | FA42~FA03                                                            | 0.0   | √  |
| FA47 | The sequence of starting No 1 relay               | 1~20                                                                 | 20    | ×  |
| FA48 | The sequence of starting No 2 relay               | 1~20                                                                 | 20    | ×  |
| FA58 | Fire pressure given value (%)                     | 0.0~100.0                                                            | 80.0  | √  |
| FA59 | Emergency fire mode                               | 0: Invalid<br>1: Emergency fire mode 1<br>2: Emergency fire mode 2   | 0     | √  |
| FA60 | Running frequency of emergency fire               | F112~F111                                                            | 50.00 | √  |
| FA62 | When fire emergency control terminal is invalid   | 0~1                                                                  | 0     | ×○ |
| FA66 | Duration time of under-load protection (S)        | 0~60                                                                 | 20.0  | √  |
| FA67 | Dormancy mode                                     | 0: dormancy mode 1<br>1: dormancy mode 2                             | 0     | ×  |
| FA68 | Given pressure offset 1 (%)                       | 0.0~100.0                                                            | 30.0  | √  |
| FA69 | Given pressure offset 2 (%)                       | 0.0~100.0                                                            | 30.0  | √  |



## Torque control parameters: FC00-FC51

|           |                                     |                                                                                                                                          |       |   |
|-----------|-------------------------------------|------------------------------------------------------------------------------------------------------------------------------------------|-------|---|
| FC00      | Speed/torque control selection      | 0: Speed control<br>1: Torque control<br>2: Terminal switchover                                                                          | 0     | √ |
| FC02      | Torque accel/decel time (S)         | 0.1~100.0                                                                                                                                | 1.0   | √ |
| FC03-FC05 | Reserved                            |                                                                                                                                          |       |   |
| FC06      | Torque given channel                | 0: Digital given (FC09)<br>1: Analog input AI1<br>2: Analog input AI2<br>3: Analog input AI3<br>4: Pulse input channel FI<br>5: Reserved | 0     | × |
| FC07      | Torque given coefficient            | 0~3.000                                                                                                                                  | 3.000 | × |
| FC08      | Reserved                            |                                                                                                                                          |       |   |
| FC09      | Torque given command value (%)      | 0~300.0                                                                                                                                  | 100.0 | √ |
| FC10-FC13 | Reserved                            |                                                                                                                                          |       |   |
| FC14      | Offset torque given channel         | 0: Digital given (FC17)<br>1: Analog input AI1<br>2: Analog input AI2<br>3: Analog input AI3<br>4: Pulse input channel FI<br>5: Reserved | 0     | × |
| FC15      | Offset torque coefficient           | 0~0.500                                                                                                                                  | 0.500 | × |
| FC16      | Offset torque cut-off frequency (%) | 0~100.0                                                                                                                                  | 10.00 | × |
| FC17      | Offset torque command value (%)     | 0~50.0                                                                                                                                   | 10.00 | √ |
| FC18-FC21 | Reserved                            |                                                                                                                                          |       |   |
| FC22      | Forward speed limited channel       | 0: Digital given (FC23)<br>1: Analog input AI1<br>2: Analog input AI2<br>3: Analog input AI3<br>4: Pulse input channel FI<br>5: Reserved | 0     | × |
| FC23      | Forward speed limited (%)           | 0~100.0                                                                                                                                  | 10.00 | √ |
| FC24      | Reverse speed limited channel       | 0: Digital given (FC25)<br>1: Analog input AI1<br>2: Analog input AI2                                                                    | 0     | × |

|      |                                     |                                                                                                                                          |        |   |
|------|-------------------------------------|------------------------------------------------------------------------------------------------------------------------------------------|--------|---|
|      |                                     | 3: Analog input AI3<br>4: Impulse input FI<br>5: Reserved                                                                                |        |   |
| FC25 | Reverse speed limited (%)           | 0~100.0                                                                                                                                  | 10.0   | √ |
| FC28 | Electric torque limited channel     | 0: Digital given (FC30)<br>1: Analog input AI1<br>2: Analog input AI2<br>3: Analog input AI3<br>4: Pulse input channel FI<br>5: Reserved | 0      | × |
| FC29 | Electric torque limited coefficient | 0~3.000                                                                                                                                  | 3.000  | × |
| FC30 | Electric torque limited (%)         | 0~300.0                                                                                                                                  | 200.0  | √ |
| FC33 | Braking torque limited channel      | 0: Digital given (FC35)<br>1: Analog input AI1<br>2: Analog input AI2<br>3: Analog input AI3<br>4: Pulse input channel FI<br>5: Reserved | 0      | × |
| FC34 | Braking torque limited coefficient  | 0~3.000                                                                                                                                  | 3.000  | × |
| FC35 | Braking torque limited (%)          | 0~300.0                                                                                                                                  | 200.00 | √ |
| FC48 | Torque switchover enabled           | 0: Invalid 1: Valid                                                                                                                      | 1      | × |
| FC49 | Current-limiting point 2 (%)        | F608~200                                                                                                                                 | 190    | √ |
| FC50 | Frequency switchover point 1(Hz)    | 1.00~FC51                                                                                                                                | 10.00  | √ |
| FC51 | Frequency switchover point 2(Hz)    | FC50~F111                                                                                                                                | 20.00  | √ |

## The second motor parameters: FE00-FE84

|      |                               |                                                                                                                                                                                                                                              |                           |    |
|------|-------------------------------|----------------------------------------------------------------------------------------------------------------------------------------------------------------------------------------------------------------------------------------------|---------------------------|----|
| FE00 | Motor switchover              | Ones: motor selection<br>0: No. 1 motor<br>1: No. 2 motor<br>2: Terminal switchover<br>Tens: control mode of No.2 motor<br>0: sensorless vector control (SVC)<br>1: Closed-loop vector control (VC)<br>2: V/F control<br>3: vector control 1 | 20                        | ×  |
| FE01 | Rated power of motor 2(kW)    | 0.1~1000.0                                                                                                                                                                                                                                   | Subject to inverter model | ×○ |
| FE02 | Rated voltage of motor 2(V)   | 1~1300                                                                                                                                                                                                                                       |                           | ×○ |
| FE03 | Rated current of motor 2(A)   | 0.2~6553.5                                                                                                                                                                                                                                   |                           | ×○ |
| FE04 | Number of motor 2 poles       | 2~100                                                                                                                                                                                                                                        | 4                         | ×○ |
| FE05 | Rated speed of motor 2(rmp)   | 1~30000                                                                                                                                                                                                                                      | Subject to inverter model | ×○ |
| FE06 | Motor 2 stator resistor       | 0.001~65.53Ω (≤15kW)<br>0.1~6553mΩ(>15kW)                                                                                                                                                                                                    | Subject to inverter model | ×○ |
| FE07 | Motor 2 rotor resistor        | 0.001~65.53Ω (≤15kW)<br>0.1~6553mΩ(>15kW)                                                                                                                                                                                                    | Subject to inverter model | ×○ |
| FE08 | Motor 2 leakage inductance    | 0.01~655.3mH (≤15kW)<br>0.001~65.53mH (>15kW)                                                                                                                                                                                                | Subject to inverter model | ×○ |
| FE09 | Motor 2 mutual inductance     | 0.01~655.3mH (≤15kW)<br>0.001~65.53mH (>15kW)                                                                                                                                                                                                | Subject to inverter model | ×○ |
| FE10 | Motor 2 rated frequency(Hz)   | 1.00~650.00                                                                                                                                                                                                                                  | 50.00                     | ×○ |
| FE11 | Motor 2 no-load current(A)    | 0.1~FE03                                                                                                                                                                                                                                     | Subject to inverter model | ×○ |
| FE12 | Type of motor 2               | 0: Normal motor<br>1: variable frequency motor                                                                                                                                                                                               | 1                         | ×  |
| FE13 | Motor 2 rotary speed loop KP1 | 1~100                                                                                                                                                                                                                                        | 30                        | √○ |
| FE14 | Motor 2 rotary speed loop KI1 | 0.01~10.00                                                                                                                                                                                                                                   | 0.50                      | √○ |
| FE15 | Motor 2 rotary speed loop KP2 | 1~100                                                                                                                                                                                                                                        | 20                        | √○ |
| FE16 | Motor 2 rotary speed loop KI2 | 0.01~10.00                                                                                                                                                                                                                                   | 1.00                      | √○ |

|      |                                                         |                                                                                                            |                           |   |
|------|---------------------------------------------------------|------------------------------------------------------------------------------------------------------------|---------------------------|---|
| FE17 | Motor 2 switching frequency 1                           | 0.00~F818                                                                                                  | 5.00                      | √ |
| FE18 | Motor 2 switching frequency 2                           | FE17~F111                                                                                                  | 10.00                     | √ |
| FE19 | Accel/decel time of motor 2                             | 0: same with accel/decel time of motor 1<br>1: 1 <sup>st</sup> accel/decel time<br>2: 2ed accel/decel time | 0                         | √ |
| FE20 | Torque compensation of motor 2                          | 1~20                                                                                                       | Subject to inverter model | × |
| FE21 | Overload coefficient of motor 2                         | 20~100                                                                                                     | 100                       | × |
| FE22 | Motor 2 overloading pre-alarm Coefficient (%)           | 50~100                                                                                                     | 80                        | × |
| FE23 | Motor 2 oscillation inhibition coefficient              | 0~100                                                                                                      | Subject to inverter model | × |
| FE24 | Reserved                                                |                                                                                                            |                           |   |
| FE25 | Motor 2 speed loop filtering constant                   | 0~100                                                                                                      | 0                         | √ |
| FE27 | Max torque when speed control                           | 0.0~250.0                                                                                                  | 200.0                     | √ |
| FE33 | Motor 2 record of the latest malfunction type           |                                                                                                            |                           | △ |
| FE34 | Motor 2 record of malfunction type for last but one     |                                                                                                            |                           | △ |
| FE35 | Motor 2 record of malfunction type for last but two     |                                                                                                            |                           | △ |
| FE36 | Motor 2 fault frequency of the latest malfunction(Hz)   |                                                                                                            |                           | △ |
| FE37 | Motor 2 fault current of the latest malfunction(A)      |                                                                                                            |                           | △ |
| FE38 | Motor 2 fault PN voltage of the latest malfunction(V)   |                                                                                                            |                           | △ |
| FE39 | Motor 2 fault frequency of last malfunction but one(Hz) |                                                                                                            |                           | △ |
| FE40 | Motor 2 fault current of last malfunction but one(A)    |                                                                                                            |                           | △ |
| FE41 | Motor 2 fault PN voltage of last malfunction but one(V) |                                                                                                            |                           | △ |
| FE42 | Motor 2 fault frequency of last malfunction but two(Hz) |                                                                                                            |                           | △ |
| FE43 | Motor 2 fault current of last malfunction but two(A)    |                                                                                                            |                           | △ |
| FE44 | Motor 2 fault PN voltage of                             |                                                                                                            |                           | △ |

|      |                                                      |            |      |    |
|------|------------------------------------------------------|------------|------|----|
|      | last malfunction but two(V)                          |            |      |    |
| FE45 | Motor 2 record of overcurrent protection fault times |            |      | △  |
| FE46 | Motor 2 record of overvoltage protection fault times |            |      | △  |
| FE47 | Motor 2 record of overheat protection fault times    |            |      | △  |
| FE48 | Motor 2 record of overload protection fault times    |            |      | △  |
| FE49 | Motor 2 software overcurrent coefficient             | 0.50~3.00  | 2.50 | ×  |
| FE50 | Motor 2 software overcurrent times                   |            |      | △  |
| FE51 | Motor 2 encoder line numbers                         | 1~9999     | 1000 | ×○ |
| FE76 | Injection current when no load                       | 0.0~100.0  | 20.0 | ×○ |
| FE77 | Injection current compensation when no load          | 0.0~50.0   | 0.0  | ×○ |
| FE78 | Compensation cut-off point                           | 0.0~50.0   | 10.0 | ×○ |
| FE79 | Injection current when heavy load                    | 0.0~100.0  | 0.0  | ×○ |
| FE80 | PCE detecting current                                | 0.1~10.0   | 0.2  | ×○ |
| FE81 | PMSM speed loop Kp                                   | 0.01~30.00 | 4.00 | ×○ |
| FE82 | PMSM speed loop Ki                                   | 0.01~10.00 | 0.20 | ×○ |
| FE83 | PMSM current loop Kp                                 | 0.1~10.0   | 1.0  | ×○ |
| FE84 | PMSM current loop Ki                                 | 0.1~10.0   | 1.0  | ×○ |

### IO expansion:

|      |                          |                     |   |   |
|------|--------------------------|---------------------|---|---|
| FF00 | Expansion relay 1 output | Refer to F300~F302. | 0 | √ |
| FF01 | Expansion relay 2 output |                     | 0 | √ |
| FF05 | Expansion input DIA      | Refer to F316~F323. | 0 | √ |
| FF06 | Expansion input DIB      |                     | 0 | √ |
| FF07 | Expansion input DIC      |                     | 0 | √ |
| FF08 | Expansion input DID      |                     | 0 | √ |

|      |                                          |                                                                                                                |   |   |
|------|------------------------------------------|----------------------------------------------------------------------------------------------------------------|---|---|
| FF09 | Expansion input negative logic selection | 0: Invalid<br>1: DIA negative logic<br>2: DIB negative logic<br>4: DIC negative logic<br>8: DID negative logic | 0 | √ |
|------|------------------------------------------|----------------------------------------------------------------------------------------------------------------|---|---|

### Parameters display:

|      |                                           |  |  |   |
|------|-------------------------------------------|--|--|---|
| H000 | Running frequency / target frequency (Hz) |  |  | Δ |
| H001 | Speed with load / target speed            |  |  | Δ |
| H002 | Output current (A)                        |  |  | Δ |
| H003 | Output voltage (V)                        |  |  | Δ |
| H004 | PN voltage (V)                            |  |  | Δ |
| H005 | PID feedback value (%)                    |  |  | Δ |
| H006 | Temperature (°C)                          |  |  | Δ |
| H007 | Count values                              |  |  | Δ |
| H008 | Linear speed                              |  |  | Δ |
| H009 | PID given value (%)                       |  |  | Δ |
| H010 | Yarn length                               |  |  | Δ |
| H011 | Center frequency (Hz)                     |  |  | Δ |
| H012 | Output power                              |  |  | Δ |
| H013 | Output torque (%)                         |  |  | Δ |
| H014 | Target torque (%)                         |  |  | Δ |
| H015 | Encoder phase sequence adjustment         |  |  | Δ |
| H016 | Reserved                                  |  |  | Δ |
| H017 | Current stage speed for multi-stage speed |  |  | Δ |
| H018 | Input pulse frequency (0.01KHz)           |  |  | Δ |
| H019 | Feedback speed (Hz)                       |  |  | Δ |
| H020 | Feedback speed (rpm)                      |  |  | Δ |
| H021 | Monitoring AI1                            |  |  | Δ |
| H022 | Monitoring AI2                            |  |  | Δ |
| H023 | Monitoring AI3                            |  |  | Δ |
| H024 | Reserved                                  |  |  | Δ |
| H025 | Power-On time (h)                         |  |  | Δ |

|               |                             |  |  |   |
|---------------|-----------------------------|--|--|---|
| H026          | Running time (h)            |  |  | △ |
| H027          | Input pulse frequency (Hz)  |  |  | △ |
| H028          | Reserved                    |  |  | △ |
| H029          | Reserved                    |  |  | △ |
| H030          | Main frequency X (Hz)       |  |  | △ |
| H031          | Accessorial frequency Y(Hz) |  |  | △ |
| H032          | Torque sent by master       |  |  | △ |
| H033          | Frequency sent by master    |  |  | △ |
| H034          | Quantity of slaves          |  |  | △ |
| H032-<br>H040 | Reserved                    |  |  | △ |

Note: × indicating that function code can only be modified in stop state.

√ indicating that function code can be modified both in stop and run state.

△ indicating that function code can only be checked in stop or run state but cannot be modified.

○ indicating that function code cannot be initialized as inverter restores manufacturer's value but can only be modified manually.

\* indicating that function code can only be modified by manufacture.

## Appendix 7 Encoder expansion card

### I Model

| Model | Function                                         |
|-------|--------------------------------------------------|
| EPG01 | Differential PG card with frequency-division     |
| EPG02 | Non-differential PG card with frequency-division |

### II Specification

#### 1) EPG01

|                | Function                         | Response speed | Output resistance | Voltage range | Output current | Frequency-division range |
|----------------|----------------------------------|----------------|-------------------|---------------|----------------|--------------------------|
| 5V,CM          | Power                            | ---            | About 300ohm      | 5V            | 300mA          | ---                      |
| A, AN<br>B, BN | Differential encoder signal      | 0~80KHz        | ---               | ±5V           | ---            | ---                      |
| OUT-A,OUT-B    | Frequency-division signal output | 0~80KHz        | About 30 ohm      | ---           | 100mA          | 1, 2~62 (even number)    |

#### 2) EPG02

|              | Function                         | Response speed | Output resistance | Voltage range | Output current | Frequency-division range |
|--------------|----------------------------------|----------------|-------------------|---------------|----------------|--------------------------|
| +15V,CM      | Power                            | ---            | About 300ohm      | 15±1.5V       | 300mA          | ---                      |
| PGA, PGB     | Non-differential encoder signal  | 0~80KHz        | ---               | 0~15V         | ---            | ---                      |
| OUT-A, OUT-B | Frequency-division signal output | 0~80KHz        | About 30 ohm      | ---           | 100mA          | 1, 2~62 (even number)    |



### III Dimension and installation

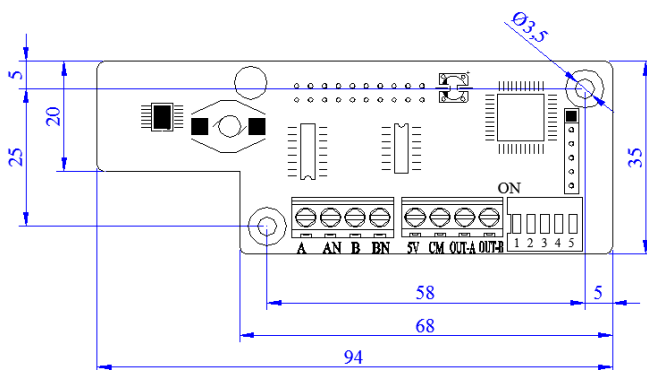

**EPG01**

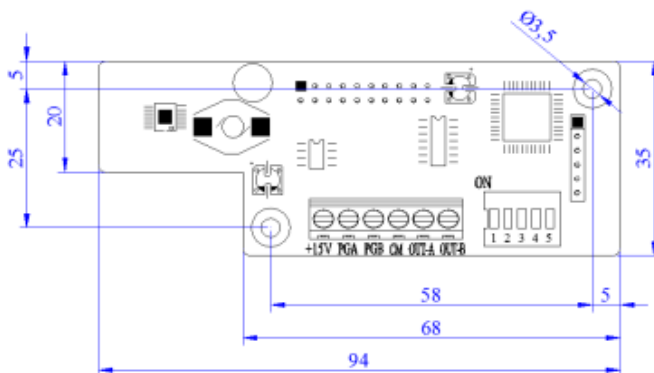

**EPG02**

For 5.5KW and above 5.5kW inverters, the expansion card is installed inside of inverter. The card is installed nearby control board, which is fastened by 3\*5 self-tapping screw. J4 connector is connected to J10 in the control board by 20-core flat cable.

For blow 4.0kW inverters, PG card is installed outside of inverter, the cable should be shorter than 30cm.

## IV Instruction

### 1. EPG01

#### 1.1 Function

PG card must be selected when the drive is at the closed-loop vector control mode. PG card includes 2 orthogonal encoder signal process circuits, which can accept encoder signal of differential output, open-collector output, and push-pull output type. EPG01 is differential output PG card. The power of differential encoder is +5V. Besides, PG card can deal with encoder signal for frequency-division output (output is 2 orthogonal signal). User can select it according to actual situation.

#### 1.2 Terminal and DIP

|          |           |          |           |           |           |              |              |
|----------|-----------|----------|-----------|-----------|-----------|--------------|--------------|
| <b>A</b> | <b>AN</b> | <b>B</b> | <b>BN</b> | <b>5V</b> | <b>CM</b> | <b>OUT-A</b> | <b>OUT-B</b> |
|----------|-----------|----------|-----------|-----------|-----------|--------------|--------------|

- A, AN, B and BN are differential encoder signal input terminals. 5V and GND are power and grounding of differential encoder. OUT-A、OUT-B + are frequency-division signal output terminals.

- The frequency-division coefficient is set by DIP switch on the PG card. DIP switch has 5-digit, binary numbers stand for coefficient. DIP 1 stands for low byte of binary, DIP 5 stands for high byte of binary. When the switch is turned to ON, it means “1” or else, it means “0”.

**Please refer to below table:**

|     | <b>Binary</b> | <b>Frequency-division coefficient</b> |
|-----|---------------|---------------------------------------|
| 0   | 00000         | 1                                     |
| 1   | 00001         | 2                                     |
| 2   | 00010         | 4                                     |
| ... | ...           | ...                                   |
| N   | ...           | 2N                                    |
| 31  | 11111         | 62                                    |

### 1.3 Diagram

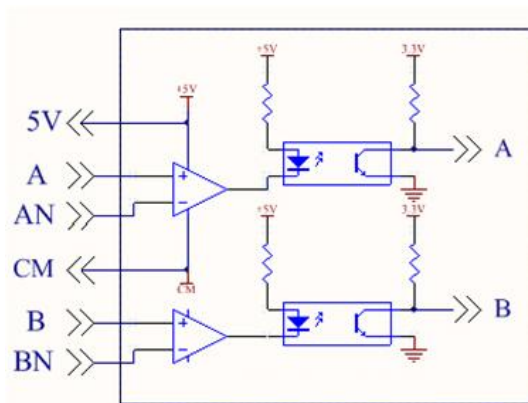

### 1.4 Frequency-division diagram

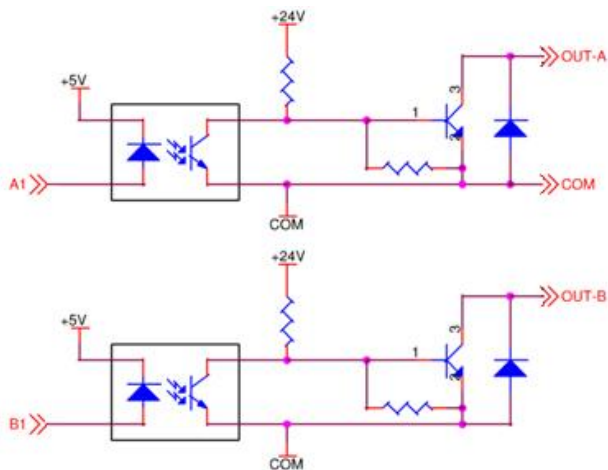

### 1.5 Caution

1. The signal wire of encoder should be far away from power wire.
2. Please select shielding wire as the encoder signal wire, and one end of it should be connected to grounding.
3. The given direction of inverter, the rotation direction of motor (from output axis of motor) and the rotation direction of encoder should be the same.

## 1.6 Connection

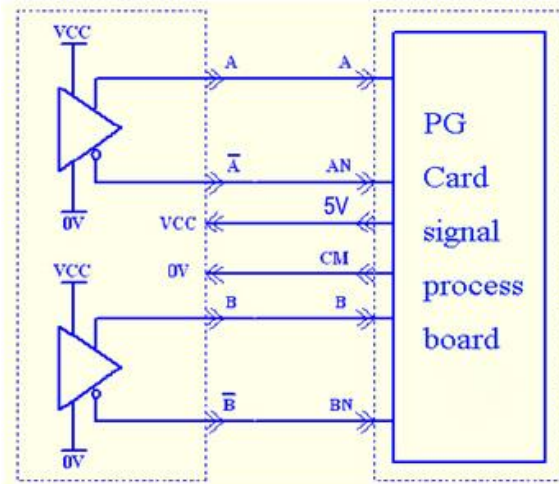

Differential output encoder (VCC=5V, please indicate it when differential encoder is selected).

## 2. EPG02

### 2.1 Function

PG card must be selected when the drive is at the closed-loop vector control mode. PG card includes 2 orthogonal encoder signal process circuits, which can accept encoder signal of differential output, open-collector output, and push-pull output type. EPG02 is non-differential output PG card. The power of differential encoder is +15V. Besides, PG card can deal with encoder signal for frequency-division output (output is 2 orthogonal signal). User can select it according to actual situation.

### 2.2 Terminal and DIP

|      |     |     |    |       |       |
|------|-----|-----|----|-------|-------|
| +15V | PGA | PGB | CM | OUT-A | OUT-B |
|------|-----|-----|----|-------|-------|

- OUT-A and OUT-B are frequency-division signal output terminals. PGA and PGB are non-differential encoder signal input terminals. +15V and CM are power and grounding of non-differential encoder.
  - The frequency-division coefficient is set by DIP switch on the PG card. DIP switch has 5-digit, binary numbers stand for coefficient. DIP 1 stands for low byte of binary, DIP 5 stands for high byte of binary. When the switch is turned to ON, it means "1" or else, it means "0".

Please refer to below table:

|   | Binary | Frequency-division coefficient |
|---|--------|--------------------------------|
| 0 | 00000  | 1                              |
| 1 | 00001  | 2                              |

|     |       |     |
|-----|-------|-----|
| 2   | 00010 | 4   |
| ... | ...   | ... |
| N   | ...   | 2N  |
| 31  | 11111 | 62  |

### 2.3 Diagram

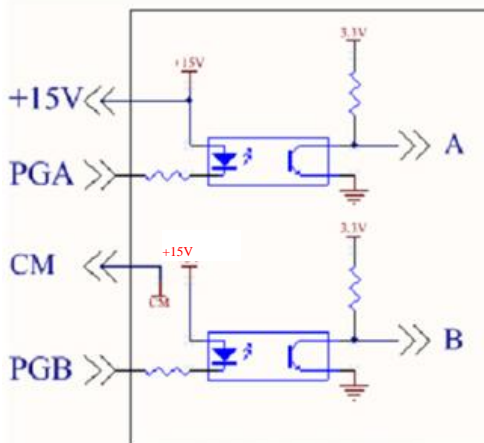

### 2.4 Frequency-division diagram

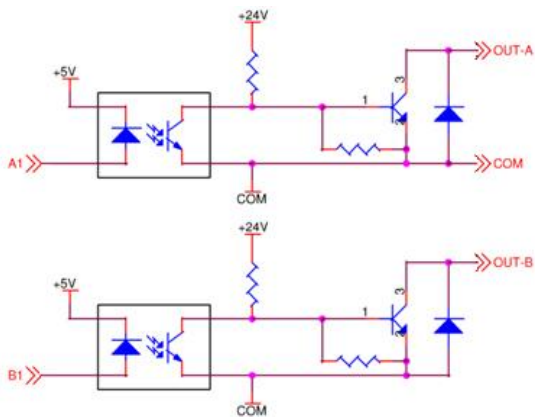

## 2.5 Caution

1. The signal wire of encoder should be far away from power wire.
2. Please select shielding wire as the encoder signal wire, and one end of it should be connected to grounding.
3. The length of shielding wire should be shorter than 30m, if user needs the wire longer than 30m, please indicate it.
4. The given direction of inverter, the rotation direction of motor (from output axis of motor) and the rotation direction of encoder should be the same.

## II. Connection

### 3.1 Open-collector output encoder

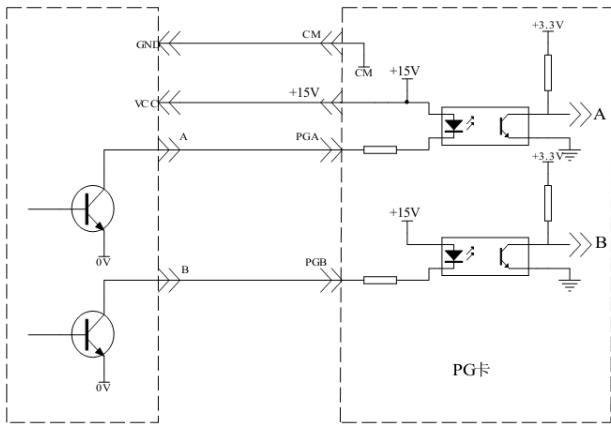

### 3.2 Push-Pull output encoder

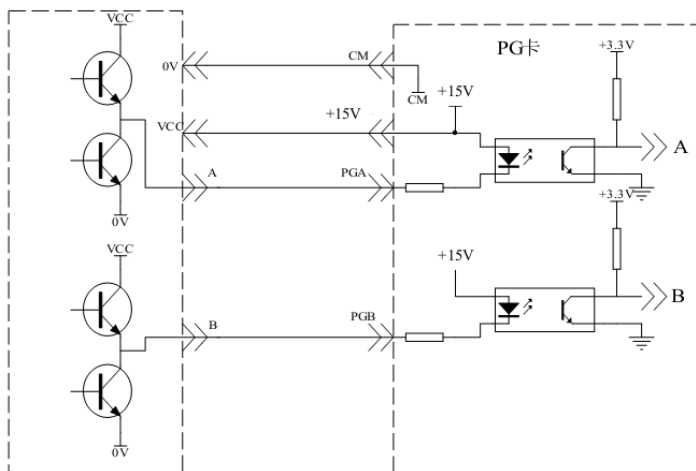

## Appendix 8 Master/slave control

### I. Overview

Master/slave control means several drives to control same system, which motor shafts are connected together with gear, chain, or conveyor. The load is averagely distributed among all drives. Master is controlled by external signal, master communicates with slaves by cables.

The link types between motors include rigid connection and flexible connection.

Rigid connection means motors are connected by gear, chain or nearer synchronous belt. The speed difference between master and slave is small, master control mode is speed control, slave control mode is torque control.

Flexible connection means motors are connected by conveyor, the speed of master and slave has a tiny difference, master control mode is speed control, and slave control mode is also speed control.

### II. signal connection

1. CAN communication is adopted.
2. CAN communication distance

|                                   |             |            |            |            |            |             |             |
|-----------------------------------|-------------|------------|------------|------------|------------|-------------|-------------|
| <b>F926</b>                       | 6           | 5          | 4          | 3          | 2          | 1           | 0           |
| <b>Baud rate (kbps)</b>           | <b>1000</b> | <b>500</b> | <b>250</b> | <b>125</b> | <b>100</b> | <b>50</b>   | <b>20</b>   |
| <b>Communication distance (m)</b> | <b>40</b>   | <b>130</b> | <b>270</b> | <b>530</b> | <b>620</b> | <b>1300</b> | <b>3300</b> |

The distance is measured value in the experiment, it has some difference with actual communication distance. User should adjust the distance according to actual situation, and shielding cable is suggested to be used.

- Control cables are connected to master, master is connected to slave by communication cable.

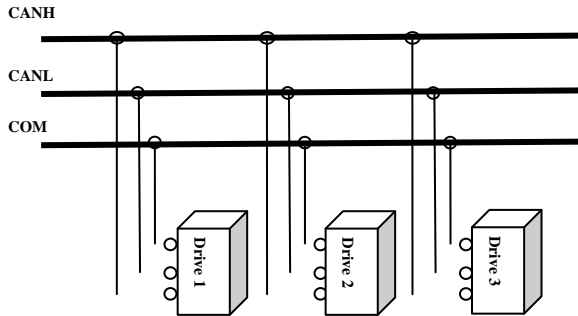

- When the application is load sharing, motors with same pole pairs and same rated frequency should be selected.

### III. System debugging

Please make sure all cables are connected correctly. Set motor parameters, test control loop and motor running when inverter runs at low frequency in V/F control mode.

Check motor running direction. Each motor should run separately in V/F control mode, all motor running directions should be same, if the running direction is different, please change any two phases of motor.

Before setting master/slave control mode, please study each motor parameters separately.

### IV. Parameters setting

- Rigid connection

Master: speed mode

| Function code | Definition              | Setting range                                                                                             | Setting value | Remarks               |
|---------------|-------------------------|-----------------------------------------------------------------------------------------------------------|---------------|-----------------------|
| F106          | Control mode            | 0: Sensorless vector control (SVC);<br>1: Closed-loop vector control (VC);<br>2: V/F; 3: Vector control 1 | 0             | Must be               |
| F111          | Max Frequency (Hz)      | F113~590.00                                                                                               | 50.00         | Same for master/slave |
| F200          | Source of start command | 0: Keypad command;<br>1: Terminal command;<br>2: Keypad+Terminal;                                         | 4             |                       |



|             |                                          |                                                                                                             |          |                              |
|-------------|------------------------------------------|-------------------------------------------------------------------------------------------------------------|----------|------------------------------|
|             |                                          | 3:MODBUS;<br>4: Keypad+Terminal+MODBUS                                                                      |          |                              |
| <b>F201</b> | Source of stop command                   | 0: Keypad command;<br>1: Terminal command;<br>2: Keypad+Terminal;<br>3:MODBUS;<br>4: Keypad+Terminal+MODBUS | <b>4</b> | <b>Must be</b>               |
| <b>F209</b> | Selecting the mode of stopping the motor | 0: stop by deceleration time;<br>1: free stop<br>2: Stop by DC braking                                      | <b>1</b> |                              |
| <b>F911</b> | Point-point communication selection      | 0:Disabled 1:Enabled                                                                                        | <b>1</b> | <b>Must be</b>               |
| <b>F912</b> | Master and slave selection               | 0:Master 1:Slave                                                                                            | <b>0</b> | <b>Must be</b>               |
| <b>F915</b> | Slave action when master stops           | 1: Free stop<br>2: Deceleration to stop                                                                     | <b>1</b> |                              |
| <b>F917</b> | Slave following master command selection | 0: given torque(torque)<br>1: given frequency 1(Droop)<br>2: given frequency 2 (Droop)                      | <b>0</b> | <b>Must be</b>               |
| <b>F926</b> | CAN baud rate (kbps)                     | 0:20 1:50 2:100<br>3:125 4: 250 5:500<br>6:1000                                                             | <b>6</b> | <b>Same for master/salve</b> |

Slave: torque mode

| <b>Function code</b> | <b>Definition</b>       | <b>Setting range</b>                                                                                        | <b>Setting value</b> | <b>Remarks</b>               |
|----------------------|-------------------------|-------------------------------------------------------------------------------------------------------------|----------------------|------------------------------|
| <b>F106</b>          | Control mode            | 0:Sensorless vector control (SVC);<br>1: Closed-loop vector control (VC);<br>2: V/F; 3: Vector control 1    | <b>0</b>             | <b>Must be</b>               |
| F111                 | Max Frequency (Hz)      | F113~590.00                                                                                                 | <b>50.00</b>         | <b>Same for master/salve</b> |
| <b>F200</b>          | Source of start command | 0: Keypad command;<br>1: Terminal command;<br>2: Keypad+Terminal;<br>3:MODBUS;<br>4: Keypad+Terminal+MODBUS | <b>4</b>             | <b>Must be</b>               |
| <b>F201</b>          | Source of stop command  | 0: Keypad command;<br>1: Terminal command;<br>2: Keypad+Terminal;<br>3:MODBUS;<br>4: Keypad+Terminal+MODBUS | <b>4</b>             | <b>Must be</b>               |

|             |                                          |                                                                                                                                                                                        |             |                              |
|-------------|------------------------------------------|----------------------------------------------------------------------------------------------------------------------------------------------------------------------------------------|-------------|------------------------------|
| <b>F203</b> | <b>Main frequency source</b>             | <b>10: modbus</b>                                                                                                                                                                      | <b>10</b>   | <b>Must be</b>               |
| <b>F209</b> | Selecting the mode of stopping the motor | 0: stop by deceleration time;<br>1: free stop<br>2: Stop by DC braking                                                                                                                 | <b>1</b>    |                              |
| <b>F911</b> | Point-point communication selection      | 0:Disabled 1:Enabled                                                                                                                                                                   | <b>1</b>    | <b>Must be</b>               |
| <b>F912</b> | Master and slave selection               | 0:Master 1:Slave                                                                                                                                                                       | <b>1</b>    | <b>Must be</b>               |
| <b>F913</b> | Running command of slave                 | 0:Slave not following running commands of master<br>1:Slave following running commands of master                                                                                       | <b>1</b>    | <b>Must be</b>               |
| <b>F914</b> | Fault information of slave               | Ones: slave fault information<br>0: Not sending fault information<br>1: Sending fault information<br>Tens: master's reaction when it loses slave's response<br>0: No reaction 1: Alarm | <b>01</b>   | <b>Must be</b>               |
| <b>F916</b> | Slave action when master stops           | 1: Free stop<br>2: Deceleration to stop                                                                                                                                                | <b>1</b>    | <b>Must be</b>               |
| <b>F917</b> | Slave following master command selection | 0: given torque(torque)<br>1: given frequency 1(Droop)<br>2: given frequency 2 (Droop)                                                                                                 | <b>0</b>    | <b>Must be</b>               |
| <b>F922</b> | <b>window</b>                            | <b>0.00~10.00</b>                                                                                                                                                                      | <b>0.50</b> |                              |
| <b>FC00</b> | Speed/torque control selection           | 0: Speed control<br>1: Torque control<br>2: Terminal switchover                                                                                                                        | <b>1</b>    | <b>Must be</b>               |
| <b>FC06</b> | Torque given channel                     | 0: Digital given (FC09)<br>1: Analog input AI1<br>2: Analog input AI2<br>3: Analog input AI3<br>4: Pulse input channel FI<br>5: Reserved                                               | <b>5</b>    | <b>Must be</b>               |
| <b>F926</b> | CAN baud rate (kbps)                     | 0:20 1:50 2:100<br>3:125 4: 250 5:500<br>6:1000                                                                                                                                        | <b>6</b>    | <b>Same for master/salve</b> |

## 2. flexible connection

## Master: speed mode

| Function code | Definition         | Setting range | Setting value | Remarks                      |
|---------------|--------------------|---------------|---------------|------------------------------|
| <b>F111</b>   | Max Frequency (Hz) | F113~590.00   | <b>50.00</b>  | <b>Same for master/salve</b> |

|             |                                          |                                                                                                                 |          |                       |
|-------------|------------------------------------------|-----------------------------------------------------------------------------------------------------------------|----------|-----------------------|
| <b>F200</b> | Source of start command                  | 0: Keypad command;<br>1: Terminal command;<br>2: Keypad+Terminal;<br>3:MODBUS;<br>4: Keypad + Terminal + MODBUS | <b>4</b> | <b>Must be</b>        |
| <b>F201</b> | Source of stop command                   | 0: Keypad command;<br>1: Terminal command;<br>2: Keypad+Terminal;<br>3:MODBUS;<br>4: Keypad + Terminal + MODBUS | <b>4</b> | <b>Must be</b>        |
| <b>F209</b> | Selecting the mode of stopping the motor | 0: stop by deceleration time;<br>1: free stop<br>2: Stop by DC braking                                          | <b>1</b> |                       |
| <b>F911</b> | Point-point communication selection      | 0:Disabled 1:Enabled                                                                                            | <b>1</b> | <b>Must be</b>        |
| F912        | Master and slave selection               | 0:Master 1:Slave                                                                                                | 0        | Must be               |
| F915        | Slave action when master stops           | 1: Free stop<br>2: Deceleration to stop                                                                         | 1        |                       |
| F917        | Slave following master command selection | 0: given torque(torque)<br>1: given frequency 1(Droop)<br>2: given frequency 2 (Droop)                          | 1        | Must be               |
| F926        | CAN baud rate (kbps)                     | 0:20 1:50 2:100<br>3:125 4: 250 5:500<br>6:1000                                                                 | 6        | Same for master/salve |

## Slave: speed mode

| <b>Function code</b> | <b>Definition</b>       | <b>Setting range</b>                                                                                            | <b>Setting value</b> | <b>Remarks</b>               |
|----------------------|-------------------------|-----------------------------------------------------------------------------------------------------------------|----------------------|------------------------------|
| <b>F111</b>          | Max Frequency (Hz)      | F113~590.00                                                                                                     | <b>50.00</b>         | <b>Same for master/salve</b> |
| F200                 | Source of start command | 0: Keypad command;<br>1: Terminal command;<br>2: Keypad+Terminal;<br>3:MODBUS;<br>4: Keypad + Terminal + MODBUS | 4                    | Must be                      |

|      |                                          |                                                                                                                                                                                        |     |                       |
|------|------------------------------------------|----------------------------------------------------------------------------------------------------------------------------------------------------------------------------------------|-----|-----------------------|
| F201 | Source of stop command                   | 0: Keypad command;<br>1: Terminal command;<br>2: Keypad+Terminal;<br>3:MODBUS;<br>4: Keypad + Terminal + MODBUS                                                                        | 4   | Must be               |
| F203 | Main frequency source                    | 10: modbus                                                                                                                                                                             | 10  | Must be               |
| F209 | Selecting the mode of stopping the motor | 0: stop by deceleration time;<br>1: free stop<br>2: Stop by DC braking                                                                                                                 | 1   |                       |
| F911 | Point-point communication selection      | 0:Disabled 1:Enabled                                                                                                                                                                   | 1   | Must be               |
| F912 | Master and slave selection               | 0:Master 1:Slave                                                                                                                                                                       | 1   | Must be               |
| F913 | Running command of slave                 | 0:Slave not following running commands of master<br>1:Slave following running commands of master                                                                                       | 1   | Must be               |
| F914 | Fault information of slave               | Ones: slave fault information<br>0: Not sending fault information<br>1: Sending fault information<br>Tens: master's reaction when it loses slave's response<br>0: No reaction 1: Alarm | 01  | Must be               |
| F916 | Slave following master command selection | 0: given torque(torque)<br>1: given frequency 1(Droop)<br>2: given frequency 2 (Droop)                                                                                                 | 1   | Must be               |
| F917 | Slave following master command selection | 0: given torque(torque)<br>1: given frequency 1(Droop)<br>2: given frequency 2 (Droop)                                                                                                 | 1   | Must be               |
| F923 | Droop control                            | 0.0 (Invalid)<br>0.1~30.0                                                                                                                                                              | 0.0 |                       |
| F926 | CAN baud rate (kbps)                     | 0:20 1:50 2:100<br>3:125 4: 250 5:500<br>6:1000                                                                                                                                        | 6   | Same for master/salve |

Note: user must set the parameters according to the table when the parameters' remarks are "must be".

**V. Remarks**

1. If baud rate must be decreased because of equipment distance, the time interval of master sending command must be extended.
2. The rated frequency of master and slave must be same.
3. The control mode (F106) of master and slave must be same.
4. Direction of master and slave must be same.
5. When rigid connection and in torque control, if slave cannot start because of low torque, torque bias should be increased.
6. Transfer boards are needed when master communicates with several slaves, please contact with manufacture.

## Appendix 9 Input filter model and dimension

| 1. Input filter model |               |                              |                            |
|-----------------------|---------------|------------------------------|----------------------------|
| Inverter model        | Filter mode   | Remarks                      |                            |
| E2000-0004S2          | FN2060-6-06   | 1-phase plastic housing      |                            |
| E2000-0007S2          | FN2060-10-06  |                              |                            |
| E2000-0015S2          | FN2060-20-06  |                              |                            |
| E2000-0022S2          | FN2060-20-06  |                              |                            |
| E2000-0002T2          | FN3258-7-44   | 3-phase 220V plastic housing |                            |
| E2000-0004T2          | FN3258-7-44   |                              |                            |
| E2000-0007T2          | FN3258-7-44   |                              |                            |
| E2000-0015T2          | FN3258-16-44  |                              |                            |
| E2000-0022T2          | FN3258-16-44  |                              |                            |
| E2000-0030T2          | FN3258-16-44  |                              |                            |
| E2000-0040T2          | FN3258-42-33  |                              |                            |
| E2000-0055T2          | FN3258-42-33  |                              |                            |
| E2000-0075T2          | FN3258-42-33  |                              |                            |
| E2000-0110T2          | FN3258-55-34  |                              |                            |
| E2000-0150T2          | FN3258-55-34  |                              |                            |
| E2000-0185T2          | FN3258-100-35 |                              |                            |
| E2000-0220T2          | FN3258-100-35 |                              |                            |
| E2000-0300T2          | FN3359-180-28 |                              | 3-phase 220V metal housing |
| E2000-0370T2          | FN3359-180-28 |                              |                            |
| E2000-0450T2          | FN3359-180-28 |                              |                            |
| E2000-0550T2          | FN3359-250-28 |                              |                            |
| E2000-0750T2          | FN3359-320-28 |                              |                            |
| E2000-0007T3          | FN3258-7-44   | 3-phase 380V plastic housing |                            |
| E2000-0015T3          | FN3258-7-44   |                              |                            |
| E2000-0022T3          | FN3258-16-44  |                              |                            |
| E2000-0030T3          | FN3258-16-44  |                              |                            |
| E2000-0040T3          | FN3258-16-44  |                              |                            |

|              |               |                            |
|--------------|---------------|----------------------------|
| E2000-0055T3 | FN3258-16-44  | 3-phase 380V metal housing |
| E2000-0075T3 | FN3258-42-33  |                            |
| E2000-0110T3 | FN3258-42-33  |                            |
| E2000-0150T3 | FN3258-42-33  |                            |
| E2000-0185T3 | FN3258-55-34  |                            |
| E2000-0220T3 | FN3258-55-34  |                            |
| E2000-0300T3 | FN3258-75-34  |                            |
| E2000-0370T3 | FN3258-100-35 |                            |
| E2000-0450T3 | FN3258-100-35 |                            |
| E2000-0550T3 | FN3359-180-28 |                            |
| E2000-0750T3 | FN3359-180-28 |                            |
| E2000-0900T3 | FN3359-250-28 |                            |
| E2000-1100T3 | FN3359-250-28 |                            |
| E2000-1320T3 | FN3359-320-28 |                            |
| E2000-1600T3 | FN3359-400-99 |                            |
| E2000-1800T3 | FN3359-400-99 |                            |

## 2. Dimension

### 1) FN2060 dimension and installation

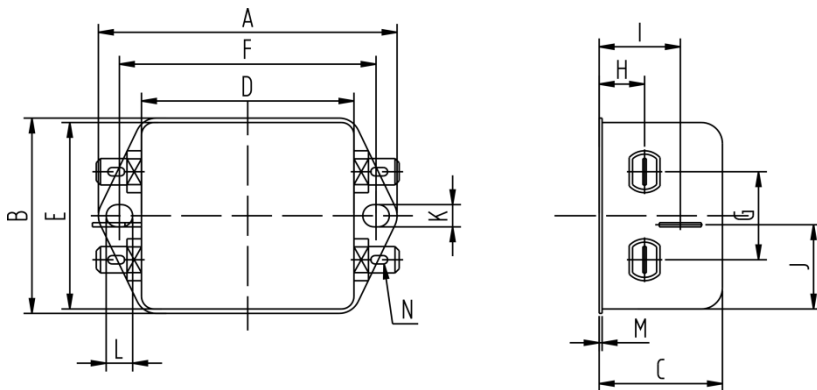

| Model | FN2060-6-06 | FN2060-10-06 | FN2060-20-06 |
|-------|-------------|--------------|--------------|
| A     | 71          | 85           | 113.5±1      |
| B     | 46.6        | 54           | 57.5±1       |
| C     | 29.3        | 30.3         | 45.4±1       |
| D     | 50.5        | 64.8         | 94±1         |
| E     | 44.5        | 49.8         | 56           |
| F     | 61          | 75           | 103          |
| G     | 21          | 27           | 25           |
| H     | 10.8        | 12.3         | 12.4         |
| I     | 19.3        | 20.8         | 32.4         |
| J     | 20.1        | 19.9         | 15.5         |
| K     | 5.3         | 5.3          | 4.4          |
| L     | 6.3         | 6.3          | 6            |
| M     | 0.7         | 0.7          | 0.9          |
| N     | 6.3×0.8     |              |              |

2) FN3258 dimension and installation

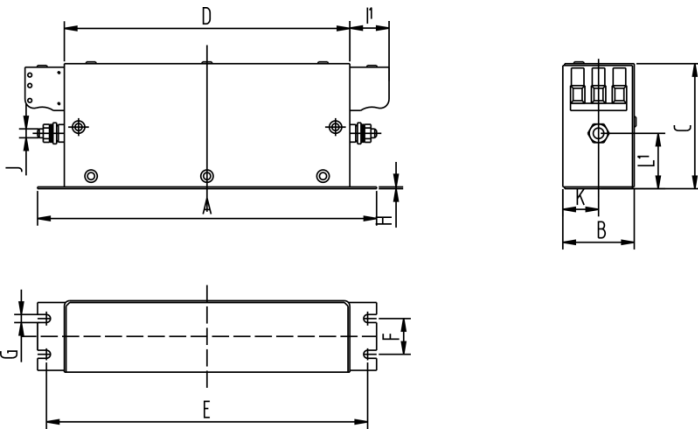



| Model | FN3258-7<br>-44 | FN3258-16<br>-44 | FN3258-42<br>-33 | FN3258-55<br>-34 | FN3258-75<br>-34 | FN3258-100<br>-35 |
|-------|-----------------|------------------|------------------|------------------|------------------|-------------------|
| A     | 190             | 250              | 310              | 250              | 270              | 270               |
| B     | 40              | 45               | 50               | 85               | 80               | 90                |
| C     | 70              | 70               | 85               | 90               | 135              | 150               |
| D     | 160             | 220              | 280              | 220              | 240              | 240               |
| E     | 180             | 235              | 295              | 235              | 255              | 255               |
| F     | 20              | 25               | 30               | 60               | 60               | 65                |
| G     | 4.5             | 5.4              | 5.4              | 5.4              | 6.5              | 6.5               |
| H     | 1               | 1                | 1                | 1                | 1.5              | 1.5               |
| II    | 22              | 22               | 25               | 39               | 39               | 45                |
| J     | M5              | M5               | M6               | M6               | M6               | M10               |
| K     | 20              | 22.5             | 25               | 42.5             | 40               | 45                |
| L1    | 29.5            | 29.5             | 37.5             | 26.5             | 70.5             | 64                |

### 3) FN3359 dimension and installation

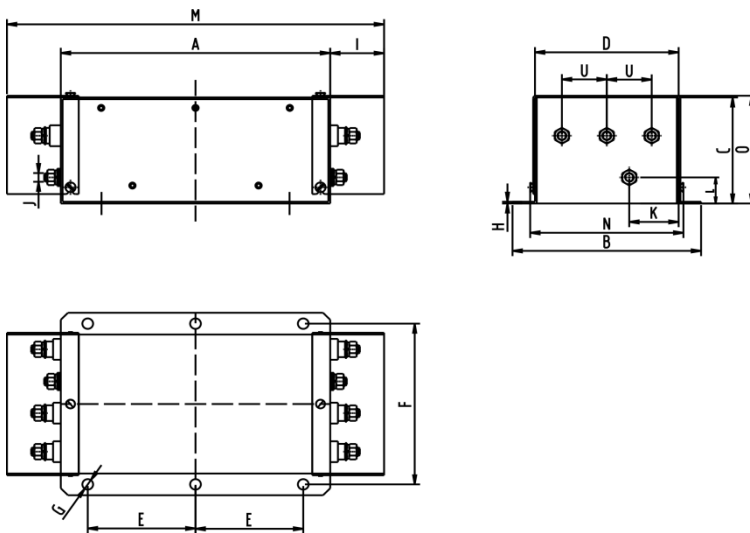

| Model | FN3359-180-28 | FN3359-250-28 |
|-------|---------------|---------------|
| A     | 300           | 300           |
| B     | 210           | 230           |
| C     | 120           | 125           |
| D     | 160           | 180           |
| E     | 120           | 120           |
| F     | 185           | 205           |
| G     | φ12           | φ12           |
| H     | 2             | 2             |
| I     | 33            | 33            |
| J     | M10           | M10           |
| K     | 55            | 62.5          |
| L     | 30            | 35            |
| M     | 420           | 420           |
| N     | 171           | 191           |
| O     | 127           | 132           |
| U     | 50            | 55            |

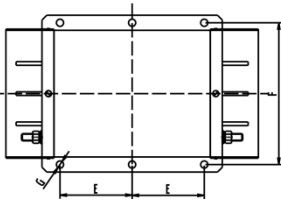
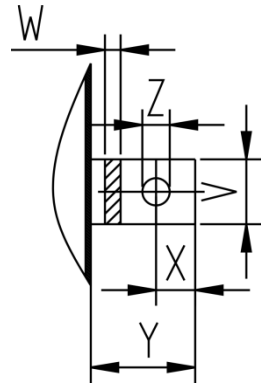
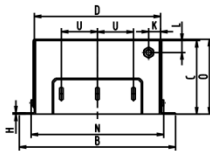
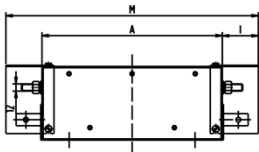

| Model | FN3359-320-28 | FN3359-400-99 |
|-------|---------------|---------------|
| A     | 300           | 300           |
| B     | 260           | 260           |
| C     | 115           | 115           |
| D     | 210           | 210           |
| E     | 120           | 120           |
| F     | 235           | 235           |
| G     | φ12           | φ12           |
| H     | 2             | 2             |
| I     | 43            | 43            |
| J     | M12           | M12           |
| K     | 20            | 20            |
| L     | 20            | 20            |
| M     | 440           | 440           |
| N     | 221           | 221           |
| O     | 122           | 122           |
| U     | 60            | 60            |
| V     | 25            | 25            |
| W     | 6             | 6             |
| X     | 15            | 15            |
| Y     | 40            | 40            |
| Z     | φ10.5         | φ10.5         |

**Note:**

1. E2000 series inverter without built-in filter satisfies the CE requirements only with an EMC filter installed on the power input side.
2. When frequency inverter model does not include R3, the customer should select above options. There is no external filter for 200kw and above 200kw AC drive; they can satisfies the CE requirements.

## Appendix 10 Bus communication

### I. EtherCAT

#### 1.1 Introduction

EtherCAT is a real-time Industrial Ethernet technology with the feature of flexible topology and easy operation. The protocol is suitable for high-speed control field because of its fast communication speed and efficient transmission rate of available data. With the CoE protocol, EtherCAT provides the same communication mechanisms as in CANopen: object dictionary, PDO, SDO and even the network management is similar. This makes it possible to implement EtherCAT with minimal effort in devices that were previously outfitted with CANopen, and large portions of the CANopen Firmware are even reusable.

#### 1.2 Installation and connection

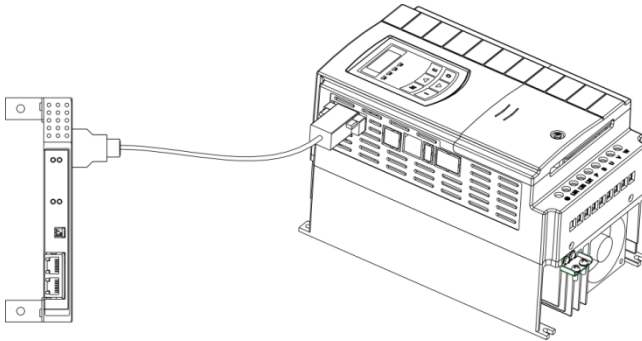

Fig1 Ether-CAT card installation

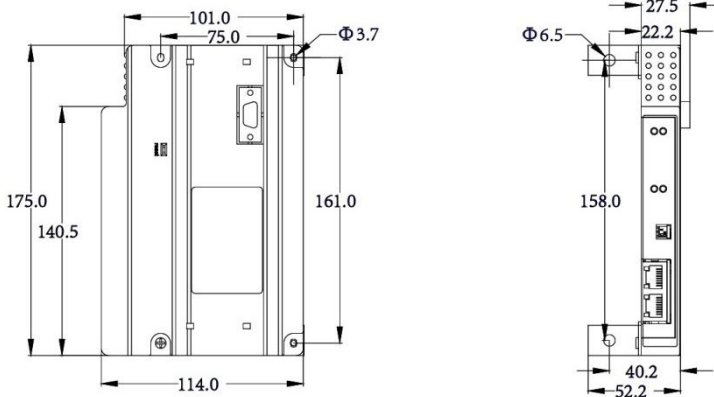

Fig2 Ether-CAT card dimension

### 1.3 Hardware layout

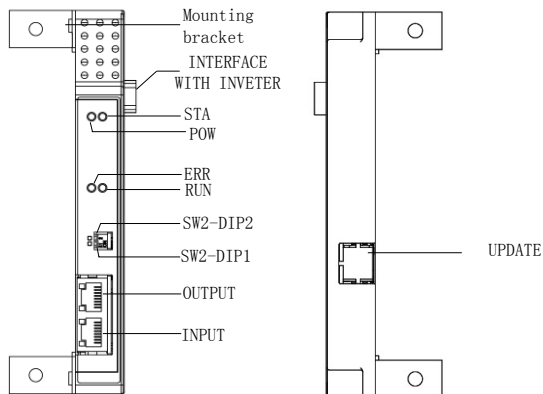

Fig 3 EtherCAT bus card

### 1.4 Topology

Line, tree, or star-chain: EtherCAT supports almost all of topologies. EtherCAT makes a pure bus or line topology with hundreds of nodes possible without the limitations that normally arise from

cascading switches or hubs.

When wiring the system, the combination of lines with branches or drop lines is beneficial: the ports necessary to create branches are directly integrated in many I/O modules, so no additional switches or active infrastructure components are required.

Additional flexibility is given regarding the possible cable types. Inexpensive industrial Ethernet cable can be used between two nodes up to 100m apart in 100BASE-TX mode.

Up to 65,535 devices can be connected to EtherCAT, so network expansion is virtually unlimited. As is usual with Ethernet, arbitrary changes between the physical layers are allowed.

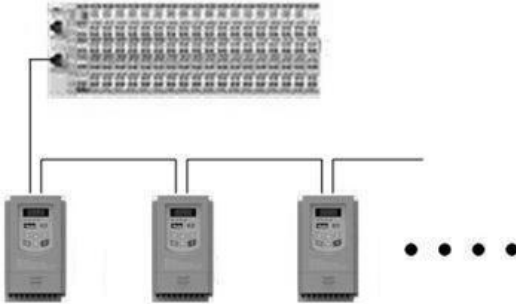

1.5 LED indicator

| Led number | Color | Function       |
|------------|-------|----------------|
| STA        | Green | STATUS         |
| POW        | Green | Power_on       |
| RUN        | Green | FieldBus_Run   |
| ERR        | Red   | FieldBus_Error |

1.6 Switch2

|          |     |                                      |
|----------|-----|--------------------------------------|
| SW2-dip1 | ON  | Download program                     |
|          | OFF | Running program                      |
| SW2-dip2 | ON  | Connect with terminal resistance.    |
|          | OFF | Disconnect with terminal resistance. |

II. CANopen

2.1 CANopen is a high layer protocol which bases on CAN serial bus system and CAL(CAN application layer). The communication card is used to connect inverter to CAN network.

2.2 Installation

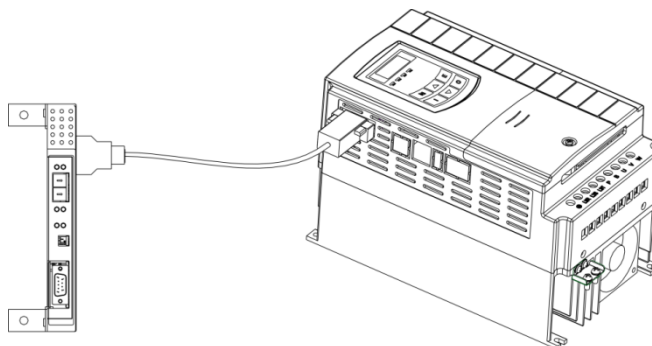

Fig 9-5 CANopen card installation

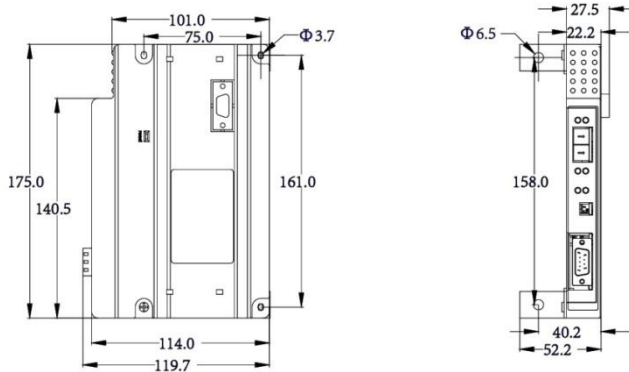

Fig 9-6 CANopen card dimension

## 2.3 DB15 interface pins

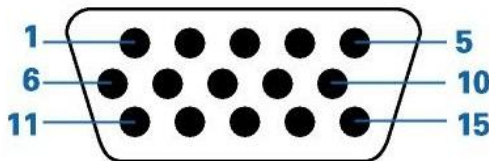
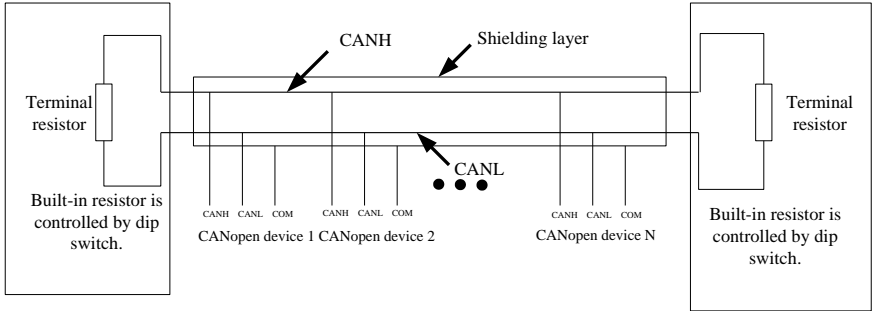

Fig 9-7 interface pins

| Pins No. | Signal cable |
|----------|--------------|
| 1, 6     | GND          |
| 2,7      | AA           |
| 3,8      | BB           |
| 4,9      | LL           |
| 5,10     | 24V          |
| 11,12    | YY           |
| 13       | M0_IN        |
| 14,15    | RES_IN       |

2.4 CAN –bus connection



2.5 Hardware layout

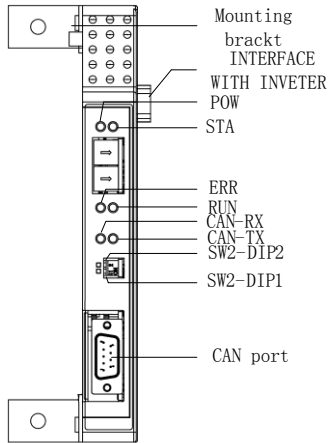



## 2.6 LED indicator

| Led number | Color | Function       |
|------------|-------|----------------|
| STA        | Green | STATUS         |
| POW        | Green | Power_on       |
| RUN        | Green | FieldBus_Run   |
| ERR        | Red   | FieldBus_Error |
| RX         | Green | CAN_RX         |
| TX         | Red   | CAN_TX         |

## 2.7 Switch code

| Switch code     | Position   | Instructions                                        |
|-----------------|------------|-----------------------------------------------------|
| <b>SW1-dip1</b> | <b>ON</b>  | Drives select 485 mode.                             |
|                 | <b>OFF</b> | Drives select 422 mode.                             |
| <b>SW1-dip2</b> | <b>ON</b>  | Connect with terminal resistance.                   |
|                 | <b>OFF</b> | Disconnect with terminal resistance.                |
| <b>SW2-dip1</b> | <b>ON</b>  | Download program                                    |
|                 | <b>OFF</b> | Download succeeds.                                  |
| <b>SW2-dip2</b> | <b>ON</b>  | Connect with terminal resistance of CAN network.    |
|                 | <b>OFF</b> | Disconnect with terminal resistance of CAN network. |

### III Profibus

#### 3.1 Introduction

PROFIBUS is a vendor independent, open fieldbus standard for a wide range of applications in manufacturing, process and building automation. Vendor independence and openness are guaranteed by the PROFIBUS standard EN50170. With PROFIBUS, devices from different manufacturers can inter-communicate. Suitable interfaces exist for PLCs, which include the Siemens, Mitsubishi and Allen Bradley range.

PROFIBUS-DP (De-central Periphery) is described in DIN 19245 Part 3, and forms part of EN 50170 with P-Net and WorldFIP. However it is important to note that P-Net and WorldFIP are wholly incompatible with PROFIBUS, using different wiring and transmission technologies.

The PROFIBUS-DP network uses a high speed version of the RS485 standard, permitting baud rates of up to 12Mbaud.

A maximum of 32 PROFIBUS-DP stations (nodes) may be contained within a single network segment. Use of RS485 repeaters allows a total of up to 126 stations.

PROFIBUS-DP is a multimaster, master-slave, token passing network. More detailed information, including a detailed guide to products available, may be obtained from the various world-wide PROFIBUS user organisations.

**3.2 Installation and connection**

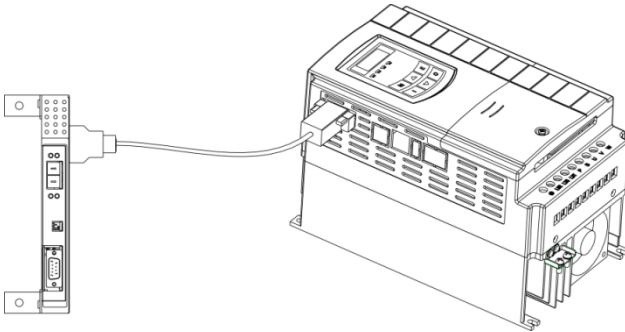

Fig 9-11 connection between communication card and inverter

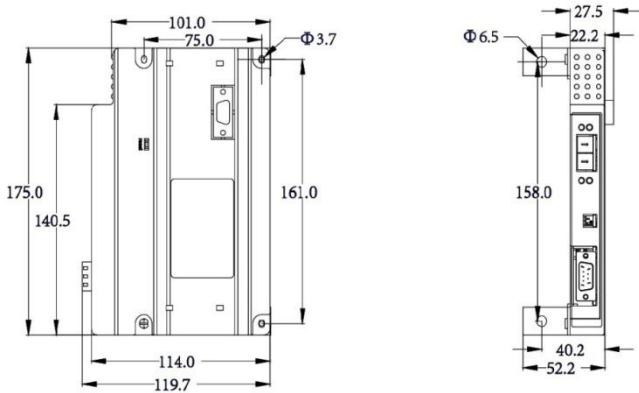
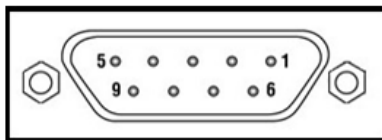

Fig 9-12 Communication card dimension

### 3.2 Pins definition



| Pins No. | Definition | Function                         |
|----------|------------|----------------------------------|
| 1        | --         | N/C                              |
| 2        | --         | N/C                              |
| 3        | RX/TX-P    | Receive/transmit data P (B-Line) |
| 4        | RTS        | Connect to relay station         |
| 5        | GND        | Grounding of 5V power            |
| 6        | 5V         | 5V power                         |
| 7        | --         | N/C                              |
| 8        | RX/TX-N    | Receive/transmit data N (A-Line) |
| 9        | --         | N/C                              |

### 3.4 Hardware layout

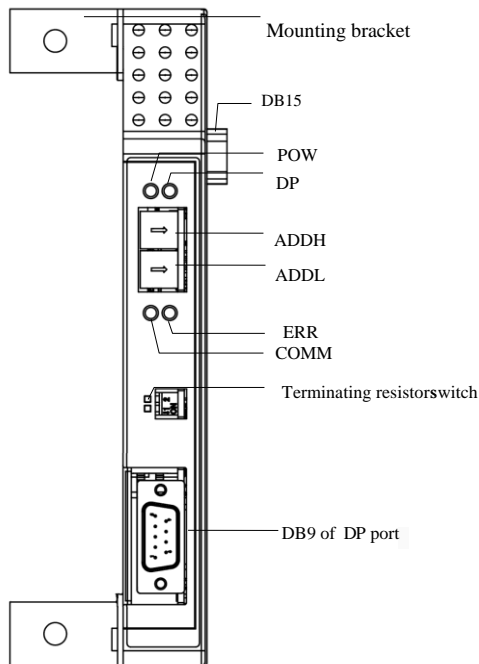

Fig 2-2 Communication card appearance and structure component

### 3.5 LED display

| LED status | POW      | DP                                     | COMM                                      | ERR                                                                     |
|------------|----------|----------------------------------------|-------------------------------------------|-------------------------------------------------------------------------|
| ON         | Power on | DP enters into data interaction state. | Communication succeeds.                   | Slave address sets wrongly or drive trips into fault status.            |
| 1Hz FLASH  | -        | -                                      | -                                         | The function code parameter address of card access inverter is illegal. |
| 2Hz FLASH  | -        | -                                      | Communication card is searching inverter. | The function code parameter data of card                                |

|     |               |                                                |   |                             |
|-----|---------------|------------------------------------------------|---|-----------------------------|
|     |               |                                                |   | access inverter is illegal. |
| OFF | Power failure | DP does not enter into data interaction state. | - | The access is correct.      |

Note: 1. 1-phase 0.4~0.75kw drives do not support Ethercat, Profibus and CANopen communication.

3. please refer to user manual of bus communication or Contact with manufacture.

#### IV BACnet

The related parameters are as below:

| Parameter | Function description  | Setting value                       | Mfr's value |
|-----------|-----------------------|-------------------------------------|-------------|
| F928      | BACnet address        | 0~127                               | 1           |
| F929      | BACnet baud rate(bps) | 0: 9600 1:19200<br>2: 38400 3:76800 | 1           |
| F933      | BACnet device number  | 0~65535                             | 1           |

2017112905B